

2V5 @ 1,5A

=> MGT Power (estimated 31 + 49 = 80 mA)
=> MGT TX (RX) Termination (estimated 11 mA)

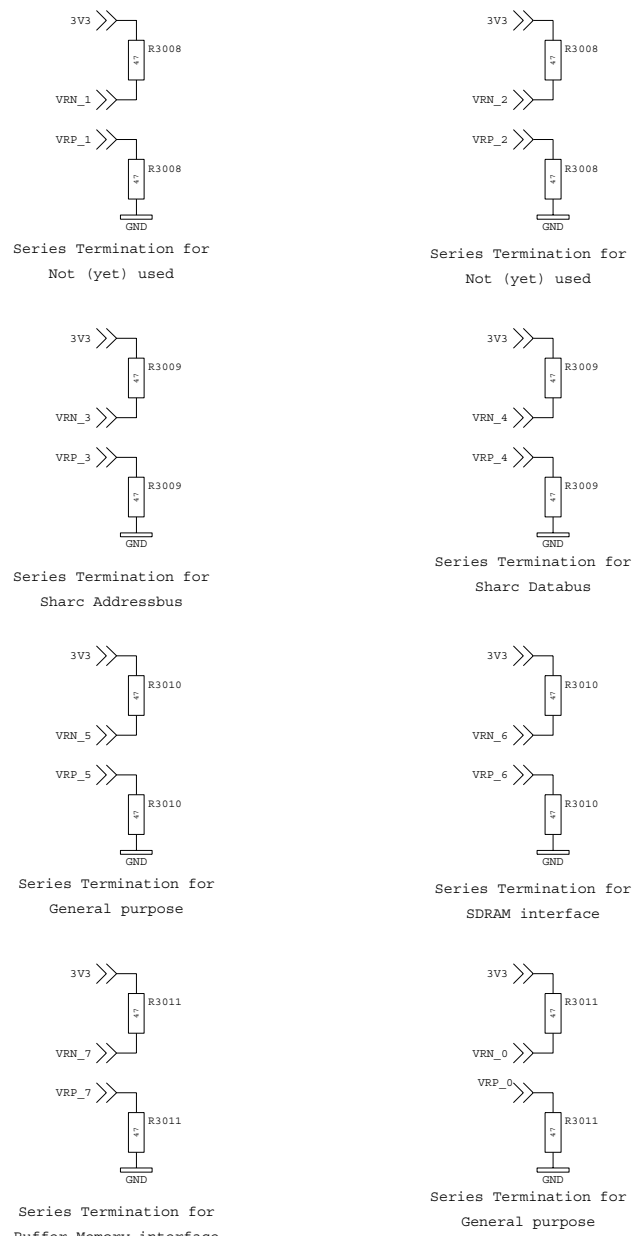
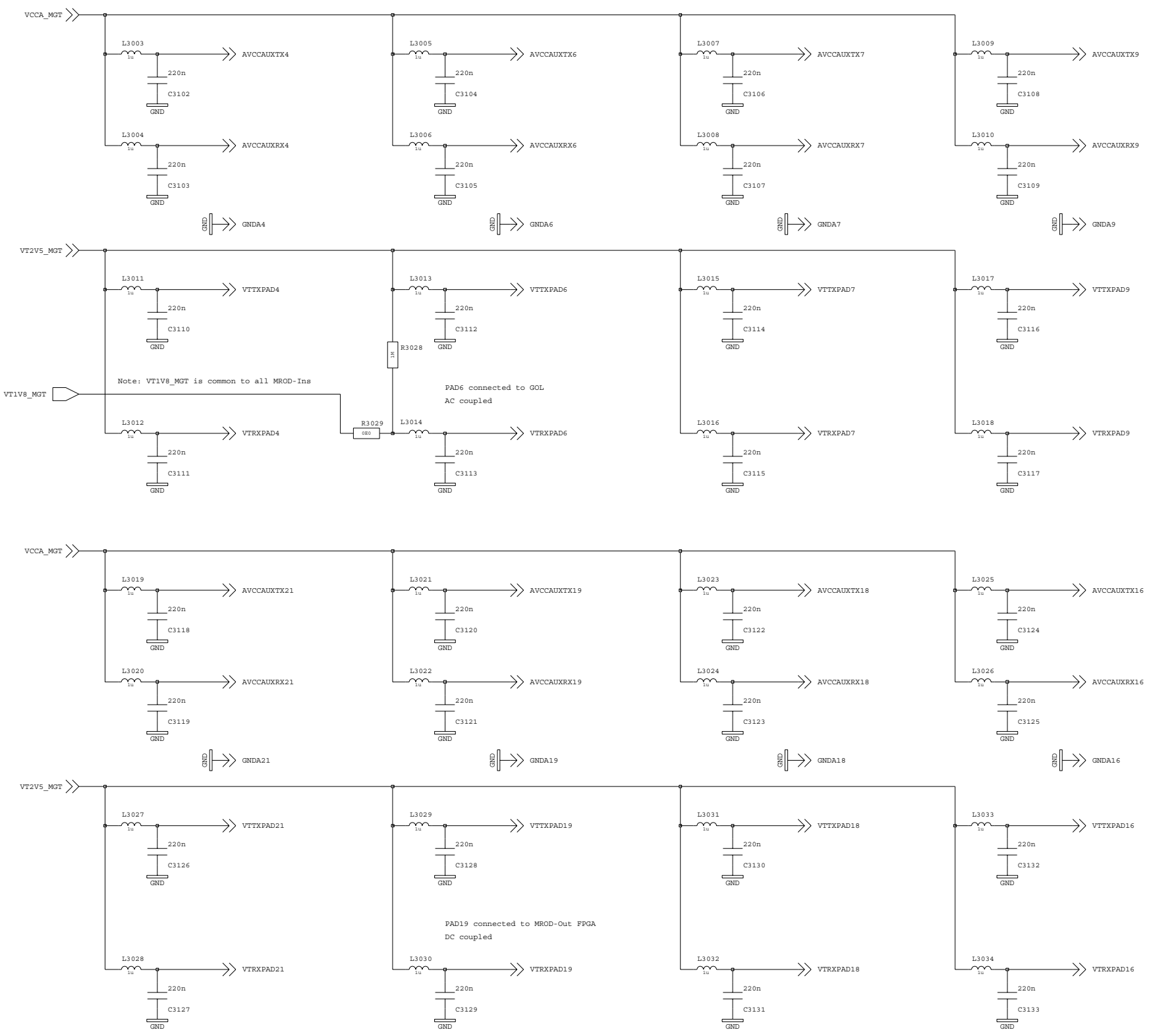
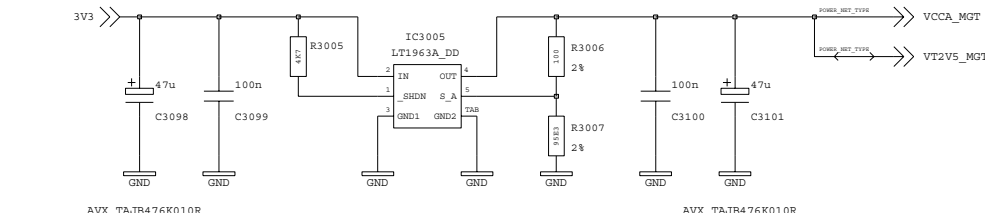

channel_in		Rev	V2	2
		Date	7 Feb 2006	
Input FPGA MGT Pwr Decoupling, Termination			Time	1:52:01 pm
Proj:	MROD-X	Proj.No:	38405	
Peter Jansweijer		peterj@nikhef.nl		
NIKHEF © T-Nikhef Amsterdam		NATIONAAL INSTITUUT VOOR KERN-FYSICA EN HOGE ENERGIE-FYSICA KRUISLAAN 409, 020-592 2000 1098 SJ AMSTERDAM NEDERLAND		
		Size	A3	4 1 4 A
		Dim	420 x 297 mm	
		Page	4	of 6