

Related topics

Space charge, initial current, saturation, Maxwellian velocity distribution, mutual conductance (“slope”), inverse amplification factor, internal resistance, amplification, work function, contact voltage, Richardson effect, three-halves power law, Barkhausen equation.

Principle and task

The I_A/U_A -characteristic curve of a diode is recorded at different heater currents and the cathode temperature and electron velocity determined therefrom. Mutual conductance, inverse amplification factor and anode resistance are determined from the characteristic curve of a triode.

Equipment

Vacuum tube panel, for EC 92	06731.00	1
Vacuum tube EC 92	06711.00	1
Plate base	06011.00	1
PEK carbon resistor 1 W 5% 1 kOhm	39104.19	1
PEK carbon resistor 1 W 5% 22 kOhm	39104.34	1
PEK capacitor /case 1/ 47 pF/ 500 V	39105.02	1
Connection box	06030.23	2
Potentiometer 250 Ohm, G2	39103.21	1
Digital multimeter	07134.00	3
Power supply, 0...600 VDC	13672.93	1
Connecting cord, 100 mm, blue	07359.04	2
Connecting cord, 250 mm, red	07360.01	3
Connecting cord, 250 mm, blue	07360.04	2
Connecting cord, 500 mm, red	07361.01	1
Connecting cord, 500 mm, blue	07361.04	2
Connecting cord, 500 mm, black	07361.05	2

Problems

1. To measure the anode current of a diode as a function of the anode voltage at different heater currents and to plot it on a graph. To calculate the cathode temperatures and electron velocities from the initial current characteristics.
2. To record the anode current of a triode as a function of the grid voltage at different anode voltages. To determine the mutual conductance, inverse amplification factor and internal resistance of the tube at a working point in the linear portion of the characteristic.

Set-up and procedure

1. Construct the circuit shown in Fig. 2. Connecting the anode and the grid gives tube EC 92 (triode) the properties of a diode.

The heater current and thus the cathode temperature can be set with the potentiometer R_1 .

Measure the anode current I_A as a function of the anode voltage U_A at different heater currents (150–110 mA) and plot the results on a graph. The voltage drop across the internal resistance R_i of the ammeter (multimeter) must be taken into account, so that $U_A = U - I_A \cdot R_i$. Stop taking measurements when I_A becomes greater than 30 mA.

Plot the initial current characteristics at different heater currents also. To do this, reverse the polarity on the voltage source and the voltmeter multimeter and measure the anode current with the microammeter (multimeter).

Because of the voltage drop across the microammeter (multimeter) the anode current U_A is:

$$U_A = -(|U| + |I_A \cdot R_i|)$$

Fig.1: Experimental set-up for measuring the characteristic curves of the electron tubes.

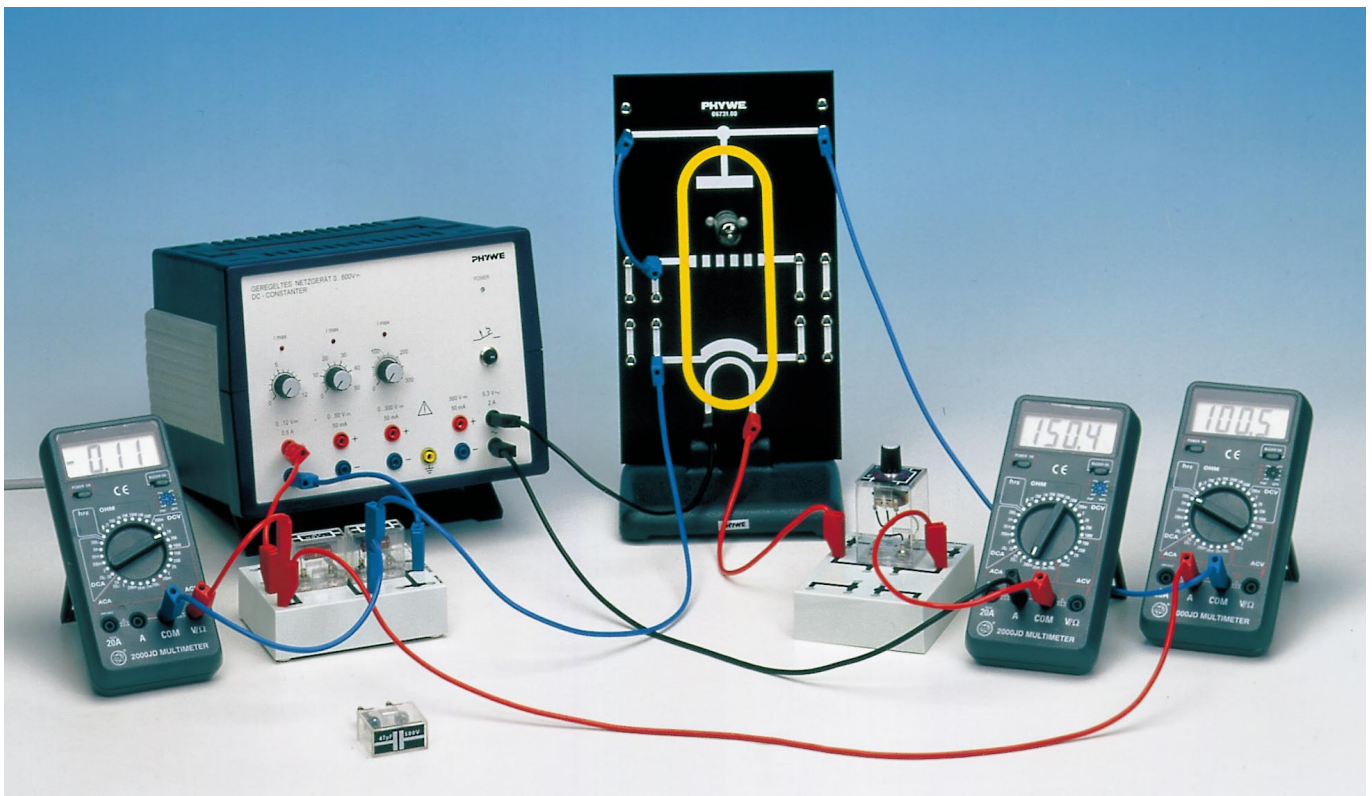

Fig. 2: Circuit for measuring the characteristics of a diode.

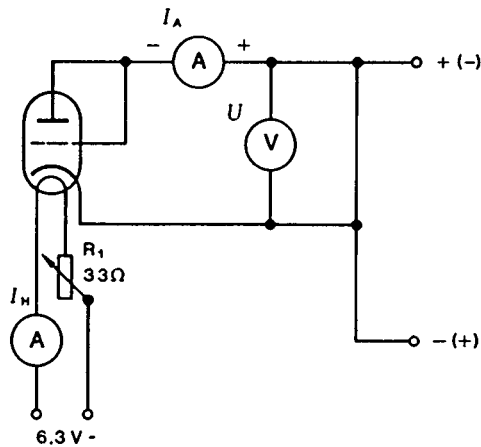
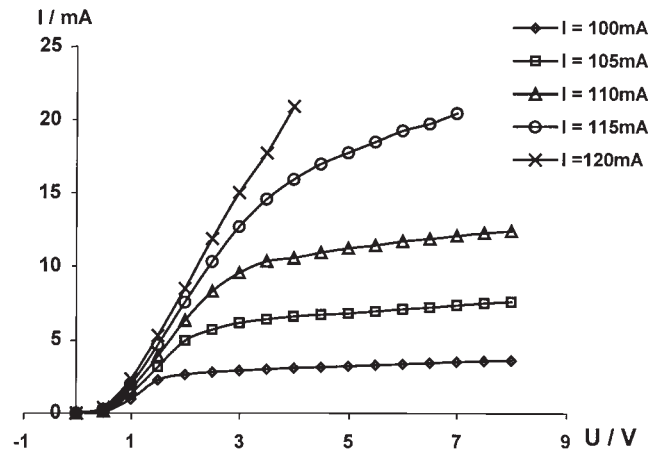

Fig. 4: Current/voltage characteristic of the diode for different heater currents.



2. Construct the circuit shown in Fig. 3. As the tubes may oscillate in the VHF range if the wiring is not altogether satisfactory, connect a small capacitor between grid and cathode to short-circuit the high frequency. Measure the anode current as a function of the grid voltage, both positive and negative, at various anode voltages (e.g. 50, 75, 100, 125, 150 V). Stop taking measurements as soon as the anode current exceeds 30 mA.

Because of the voltage drop across the internal resistance R_i of the ammeter, the anode voltage is represented by

$$U_A = U - I_A \cdot R_i$$

Plot the I_A/U_G -characteristics (control characteristics) on a graph.

Theory and evaluation

We distinguish three different regions in the current/voltage characteristic of a vacuum diode: the initial current, space charge and saturation regions.

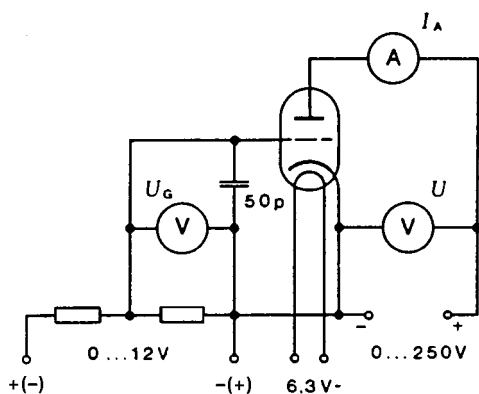

Fig. 3: Circuit for measuring the characteristic curves of a triode.

A current still flows through the vacuum diode when the anode is negative with respect to the cathode ($U_A < 0$). This current, which is known as the “initial current”, bears the following relationship to the (negative) anode voltage:

$$I_A = I_0 \cdot \exp - \left| \frac{eU_A}{kT} \right| .$$

The electrons contributing to this current still have, as the result of their Maxwellian velocity distribution, sufficient kinetic energy after they have left the cathode to surmount the anode field and reach the anode.

The emitted electrons first form round the cathode an electron cloud from which slow-moving electrons rebound and can thus return to the cathode. If we apply a positive voltage to the anode, some electrons are drawn out and the cloud becomes less dense as the anode voltage increases. In this part of the curve (space-charge region) the equation

$$I_A = P \cdot U_A^{\frac{3}{2}} ,$$

applies, where P = the tube constant.

As the anode voltage is increased still further, in the end all the electrons emitted from the cathode are collected, the space charge disappears and the tube reaches saturation. Changing the anode voltage no longer brings about a corresponding change in the anode current.

If we insert another grid-like electrode between cathode and anode we obtain a three-electrode valve, or triode. The anode current can be controlled by a voltage applied between the grid and the cathode. But as it is controlled also (but to a lesser extent) by the anode voltage U_A , the two voltages combine to give a resultant control voltage

$$U_c = U_G + D \cdot U_A .$$

The so-called “inverse amplification factor” D is a constant at a given working point A and is defined by

$$D = \frac{\partial U_G}{\partial U_A} \text{ at constant } I_A .$$

Since electron tubes generally work in the space-charge region, the anode current is essentially expressed by the space-charge formula

$$I_A = P (U_G + D \cdot U_A)^{\frac{3}{2}}$$

The gradient of the I_A/U_G characteristic at working point A is called the "slope" S or "mutual conductance":

$$S = \frac{\partial I_A}{\partial U_G} \text{ at constant } U_A.$$

We obtain likewise the tube resistance R_i at working point A and at constant grid voltage:

$$R_i = \frac{\partial U_A}{\partial I_A} \text{ at constant } U_G.$$

These three variables are interrelated by the Barkhausen equation (the "tube equation"):

$$DSR_i = 1$$

1. If we plot the anode current against the (negative) and voltage semi-logarithmically in the initial current range of the diode we obtain a straight line of slope

$$\beta = - \frac{e}{kT_c} \text{ (cf. Fig. 5)}$$

in accordance with

$$\ln I_A = \ln I_0 - \left| \frac{eU_A}{kT_c} \right|,$$

where e = the electron charge = 1.60×10^{-19} As, and k = the Boltzmann constant = 1.38×10^{-23} VAsk⁻¹.

From this, we can calculate the cathode temperature

$$T_c = - \frac{e}{k\beta}.$$

For a Maxwellian distribution the electron velocities v are calculated in accordance with

$$\frac{1}{N_0} \frac{dN}{dv} = \frac{4}{\sqrt{\pi}} \left(\frac{m}{2kT} \right)^{\frac{3}{2}} \cdot v^2 \cdot \exp - \frac{mv^2}{2kT}$$

where N_0 is the total number of electrons and m (the rest-mass of the electron) is 9.11×10^{-31} kg.

From this we obtain the most probable velocity

$$v_p = \sqrt{\frac{2kT}{m}}$$

and the mean velocity

$$v_m = \sqrt{\frac{4}{\pi}} \cdot v_p$$

By fitting to exponential curves, using the expression

$$I_A = A \cdot e^{B \cdot U_A}$$

Fig. 5: Initial current of the diode at different heater currents.

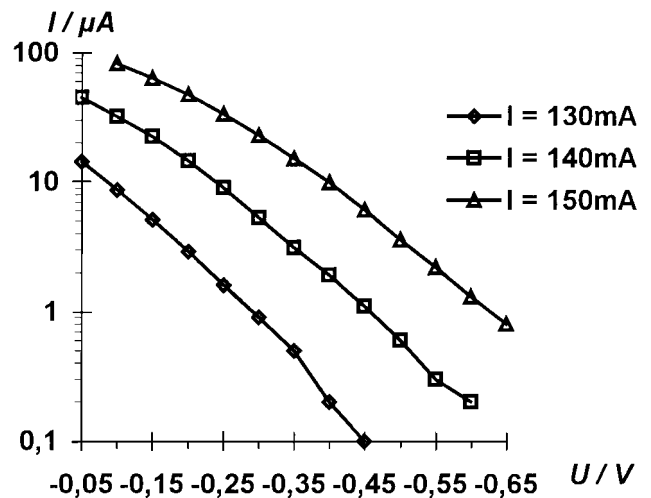

we obtain from the measured values in Fig. 5 the exponents B, as follows:

$$B_1 = 8.36 \text{ V}^{-1} \text{ (150 mA)}$$

$$B_2 = 9.84 \text{ V}^{-1} \text{ (140 mA)}$$

$$B_3 = 11.24 \text{ V}^{-1} \text{ (130 mA)}$$

and hence the cathode temperatures T:

$$T_1 = 1390 \text{ K (150 mA)}$$

$$T_2 = 1180 \text{ K (140 mA)}$$

$$T_3 = 1030 \text{ K (130 mA)}$$

The most probable velocities at different cathode temperatures are then:

$$v_p(T_1) = 204 \cdot 10^3 \text{ m s}^{-1}$$

$$v_p(T_2) = 189 \cdot 10^3 \text{ m s}^{-1}$$

$$v_p(T_3) = 177 \cdot 10^3 \text{ m s}^{-1}$$

2. Fig. 6 shows the triode control characteristics measured. If we take working point A (U_A , I_A , U_G) in the linear portion of the family characteristics we can determine all the characteristics of the tube. For A (100 V, 20 mA, 1 V) we obtain

$$S = 10 \frac{\text{mA}}{\text{V}}$$

for the "slope" S (gradient of the curve at point A).

The inverse amplification factor D is obtained by going from the 150 V to the 50 V characteristic through A and parallel to the U_G -axis and reading off

$$\frac{-\Delta U_G}{\Delta U_A}, \text{ from which } D = 0.018.$$

To obtain the tube resistance R_i , we go from the 50 V to the 150 V characteristic through A and parallel to the I_A -axis and read off

$$\frac{\Delta U_A}{\Delta I_A}, \text{ from which } R_i = 5.85 \text{ k}\Omega.$$

If we substitute the values obtained in the Barkhausen equation we obtain

$$DSR_i = 0.02 \times 5.7 \times 9.4 = 1.07 \approx 1.$$

Notes

Strictly speaking the anode voltage U_A is always obtained from the applied voltage minus the difference between the electron work function voltages at the cathode ϕ_C and the anode ϕ_A :

$$U_A = U - (\phi_A - \phi_C).$$

Secondary phenomena caused by the Maxwellian velocity distribution of the electrons are also neglected.

The open-loop voltage gain $\mu = D^{-1}$ is often quoted instead of the inverse amplification factor D .

When grid and anode are connected together, the greater part of the current flows through the grid.