

Contents

1	Electrostatics	5
1.1	History and basics	5
1.2	Electrical Force and Field	6
1.2.1	Coulomb's law	6
1.2.2	The electrical field	8
1.2.3	Knowledge and Skills	13
1.3	Electrical flux and Gauss' Law	13
1.3.1	Electrical field lines and electrical flux	13
1.3.2	Gauss' Law	15
1.3.3	Validity of Gauss' Law	17
1.3.4	Applications of Gauss's law	18
1.3.5	Knowledge and Skills	22
1.4	More on electrical field equations	23
1.4.1	Flux and divergence	23
1.4.2	Gauss' Law and Gauss' Theorem	25
1.4.3	Gauss' Law for a charged sphere	25
1.4.4	The loop integral of the electrical field	26
1.4.5	Knowledge and Skills	27
1.5	The electric potential	27
1.5.1	Work in a gravitational field	27
1.5.2	Potential energy in an electric field	28
1.5.3	The definition of the electric potential	29
1.5.4	The potential and the electrical field	29
1.5.5	The energy of a charge configuration	35
1.5.6	The energy of continuous charge distribution	36
1.5.7	The energy in the electrical field	36
1.5.8	Knowledge and Skills	38
1.6	Electrical fields in matter	39
1.6.1	The Conductor	39
1.6.2	Capacitors	46
1.6.3	Knowledge and Skills	49
1.7	Insulators	50
1.7.1	Polarization of atoms and molecules	50
1.7.2	Macroscopic Polarization	51
1.7.3	The electrical Displacement	54
1.7.4	Knowledge and Skills	55

1.8	The icons of Electrostatics	56
2	Magnetostatics	57
2.1	Basic concepts	57
2.2	Lorentz force	57
2.2.1	Experimental basis and formulation	57
2.2.2	The direction of the Lorentz force	59
2.2.3	A force without work	60
2.2.4	The right-hand-rule	60
2.2.5	Example: force on a wire	60
2.2.6	Current loops & Magnetic dipoles	61
2.3	Biot-Savart's law	62
2.3.1	A wire with a current	63
2.3.2	Two parallel wires	65
2.3.3	Knowledge and Skills	66
2.4	Intermezzo: Current densities	66
2.5	Ampere's law	67
2.5.1	Thick wire with a current	68
2.5.2	Plane with a homogeneous current density	69
2.5.3	The Solenoid	70
2.5.4	Knowledge and Skills	71
2.6	Field equations	72
2.6.1	Stokes' theorem	72
2.6.2	Stokes theorem: example	73
2.6.3	The curl of \vec{B}	74
2.6.4	The divergence of \vec{B}	75
2.6.5	Summary: Field equations for \vec{E} and \vec{B} fields	76
2.6.6	Knowledge and Skills	76
2.7	Magnetic fields in matter	77
2.7.1	Paramagnetism: electron spin	77
2.7.2	Paramagnetism: Electron orbit	78
2.7.3	Diamagnetism	78
2.7.4	Magnetization and Bound Currents	79
2.7.5	Linear materials	80
2.7.6	Ferromagnetism	82
2.7.7	Knowledge and Skills	83
3	Electrodynamics	85
3.1	Introduction	85
3.2	Current and force	85
3.2.1	Why does current flow?	85
3.2.2	Ohm's law	86
3.2.3	Electromotive force	87
3.2.4	Induced EMF	88
3.2.5	Faraday's law	89
3.2.6	Knowledge and skills	90
3.3	Electromagnetic inductance and circuits	91

3.3.1	Self-inductance	91
3.3.2	Mutual inductance	93
3.3.3	Electric circuits	95
3.3.4	Energy in electric circuits	97
3.3.5	Knowledge and skills	99
3.4	Maxwell equations	99
3.4.1	The Maxwell term from a gedanken experiment	100
3.4.2	The Maxwell term from a controlled charge explosion	101
3.4.3	Continuity equation	102
3.4.4	The complete set of Maxwell equations	103
3.4.5	Electromagnetic waves	103
3.4.6	Knowledge and skills	105

Chapter 1

Electrostatics

1.1 History and basics

The word electricity is derived from $\eta\lambda\epsilon\kappa\tau\rho\nu$ (*elektron*), the Greek word for amber. The reference to amber is not a coincidence: when an amber rod is rubbed with fur it attracts certain objects, such as a piece of paper or a hair. This was documented first by Thales of Miletus (600 BC).

Amber is not unique in this sense. Many other materials, such as glass, rubber, PVC and Ebony can be electrified by rubbing it with for example fur, silk or wool. Many experiments in the 17th and 18th century were conducted to study this phenomenon. This work led to the discovery of two kinds of electricity (positive and negative charge) that attract, while electricity of the same kind repels. A simple experiment with a glass rod and a plastic ball as illustrated in Fig. 1.1 shows that like charges repel. Another experiment, using an additional rubber rod and ball with opposite electrical charge

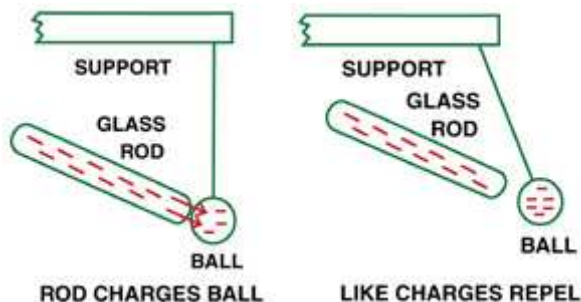

Figure 1.1: A glass rod is electrically charged by rubbing it with fur. The rod is then used to charge a plastic ball. Now the two objects repel.

demonstrates that unlike charges attract, see Fig. 1.2. Well known is the glass rod that, rubbed with a silk cloth, obtains a 'positive' electrification. Famous is the Ebony rod that after being rubbed with a cat's skin is 'negative' electrified.

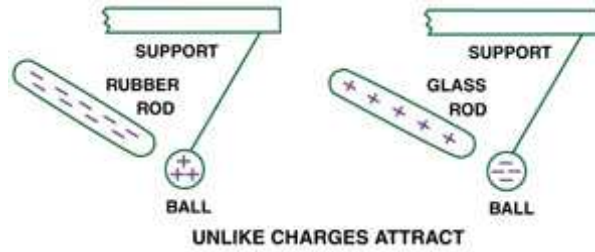

Figure 1.2: The rod and ball have opposite electrical charge. The two objects attract.

1.2 Electrical Force and Field

1.2.1 Coulomb's law

Charles Augustin Coulomb (1736 - 1806) was a French physicist who studied the electrical forces in a quantitative manner utilizing a torsion balance. Through this experimentation, Coulomb found that the force between two (point) charges is given by:

$$\vec{F} = \frac{1}{4\pi\epsilon_0} \frac{qQ}{r^2} \hat{r} \quad (1.1)$$

where $r = |\vec{r}|$ represents the distance between the test charge q and source charge Q . The vector \vec{r} connects the two charges. The direction of the force \vec{F} is given by $\hat{r} = \frac{\vec{r}}{|\vec{r}|}$, the unit vector pointing from Q to q , see also Fig.1.3. Equivalently, we can write for the Coulomb force:

$$\vec{F} = \frac{1}{4\pi\epsilon_0} \frac{qQ}{r^2} \frac{\vec{r}}{|\vec{r}|} = \frac{1}{4\pi\epsilon_0} \frac{qQ}{r^3} \vec{r} \quad (1.2)$$

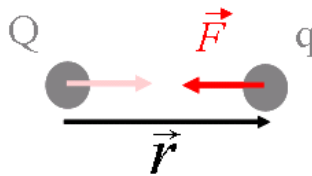

Figure 1.3: The Coulomb force between a source charge Q and a test charge q .

The SI unit of electrical charge is the Coulomb, which can be abbreviated to the unit C in equations. The factor $\frac{1}{4\pi\epsilon_0}$ is a constant term with ϵ_0 called the 'electrical permittivity'. The electrical permittivity has the numerical value:

$$\epsilon_0 = 8.85419 \times 10^{-12} \frac{\text{C}^2}{\text{Nm}^2} \quad (1.3)$$

Often, Coulomb's law is also written as

$$\vec{F} = K \frac{qQ}{r^2} \hat{r} \quad (1.4)$$

with K the electrical constant:

$$K = 8.98755 \times 10^9 \frac{\text{Nm}^2}{\text{C}^2} \quad (1.5)$$

Coulomb's law is about the electrical force between two point charges. If we have three, four or whatever number of charges at different positions, the total force on a test charge becomes:

$$\vec{F} = \vec{F}_1 + \vec{F}_2 + \vec{F}_3 + \vec{F}_4 + \dots \quad (1.6)$$

with \vec{F}_i the electrical force by source charge Q_i on our test charge given by equation 1.1. Using this 'superposition principle' we can write this total force as:

$$\vec{F} = \sum_{i=1, N} \frac{1}{4\pi\epsilon_0} \frac{qQ_i}{|\vec{r}_0 - \vec{r}_i|^2} \frac{\vec{r}_0 - \vec{r}_i}{|\vec{r}_0 - \vec{r}_i|} \quad (1.7)$$

with the position of the N charges Q_i denoted as \vec{r}_i and the position of the test charge \vec{r}_0 . The superposition principle is illustrated in Fig. 1.4. The vectors are defined with respect to some origin O . Note that the expression for the electrical force is independent on the choice of origin O .

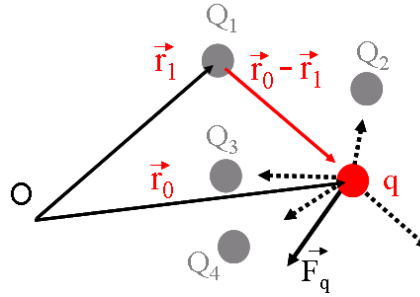

Figure 1.4: The Coulomb force on a test charge q on position r_0 resulting from four source charges Q_1, \dots, Q_4 . The connection vector, $\vec{r}_0 - \vec{r}_1$ between charge Q_1 and the test charge q is also indicated. The vectors \vec{r}_0 and \vec{r}_1 are defined with respect to origin O .

The physicist J.J. Thomson discovered in 1897 a new elementary particle: the electron. The electron carries a negative electrical charge and is responsible for most electrical currents. R.A. Millikan discovered in 1909 that all electrons carry a similar charge, $-e$, called the elementary charge. In SI units its value is

$$e = 1.6002 \times 10^{-19} \text{C} \quad (1.8)$$

We know now that in atoms negative charge is carried by electrons, while protons are positively charged. When we go back to the old experiment, rubbing an ebony rod with fur or cat's skin, the electrons from the cat's skin get transferred to the ebony rod. The cat's skin now has a deficiency of electrons and so is positively charged. On the other hand, the ebony rod has an excess of electrons and hence is negatively charged. So, in everyday life, positive electrification is due to the deficiency of electrons and thus not by an excess of protons.

Protons are not so elementary as electrons. Protons consists of quarks and gluons. The quarks carry electrical charge of $-\frac{1}{3}e$ and $+\frac{2}{3}e$. In nature, the quarks and gluons are confined in other particles (like the proton). Scientific research in the field of 'particle physics' has led to a new 'table of elements', one with six quarks and six 'leptons' which interact by the exchange of force particles. The particle world is illustrated by the table in Fig. 1.5. All these particles exist in nature,

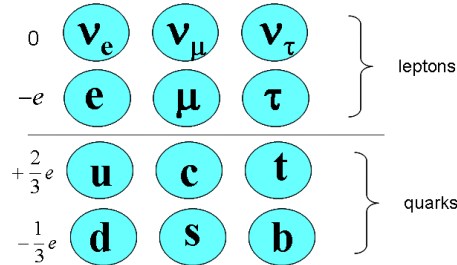

Figure 1.5: *The elementary particles. The leptons from left to right are: electron-neutrino, muon-neutrino, tau-neutrino, electron, muon, tauon. The quarks, in the same order, are: up, charm, top, down, strange, bottom. From left to right, the mass of the particles is increasing. For example, an up quark 'weighs' a few MeV while a top quarks weighs 175 GeV (for reference: a proton weighs 1 GeV). This mass difference between the particles is an open question, but the so called Higgs mechanism may be its origin.*

but one to remember is that our everyday world is made off only three particles: up and down quarks and electrons. Electrical charge in nature comes in discrete amounts: it is quantized, which has deep implications. The net charge before an interaction is equal to the charge after an interaction.

Elementary particles like quarks and gluons are studied in particle collisions at particle laboratories like CERN (Geneva) and Fermilab (Chicago) using large accelerators. Presently at CERN a new accelerator is being constructed, the Large Hadron Collider (LHC). The apparatus with a circumference of 27 km accelerates protons clockwise and counter-clockwise to energies of 7 TeV. At a few dedicated points, interaction points, the protons collide. The detectors to measure the products (i.c. new particles) of these collisions are large, typically $20 \times 20 \times 20 \text{ m}^3$. In the Netherlands, NIKHEF in Amsterdam, is the main institute where research in this field is being conducted. NIKHEF contributes to ATLAS, a detector for the LHC, as shown in Fig. 1.6. Although ATLAS is a multipurpose detector, the focus of the research program is on the Higgs particle.

1.2.2 The electrical field

Let's have a closer look to equation 1.7 and rewrite it:

$$\vec{F} = q \left(\sum_{i=1,N} \frac{1}{4\pi\epsilon_0} \frac{Q_i}{|\vec{r}_0 - \vec{r}_i|^2} \frac{\vec{r}_0 - \vec{r}_i}{|\vec{r}_0 - \vec{r}_i|} \right) \quad (1.9)$$

The electrical field \vec{E} is defined by:

$$\vec{F} = q\vec{E}, \quad (1.10)$$

with:

$$\vec{E} = \sum_{i=1,N} \frac{1}{4\pi\epsilon_0} \frac{Q_i}{|\vec{r}_0 - \vec{r}_i|^2} \frac{\vec{r}_0 - \vec{r}_i}{|\vec{r}_0 - \vec{r}_i|}. \quad (1.11)$$

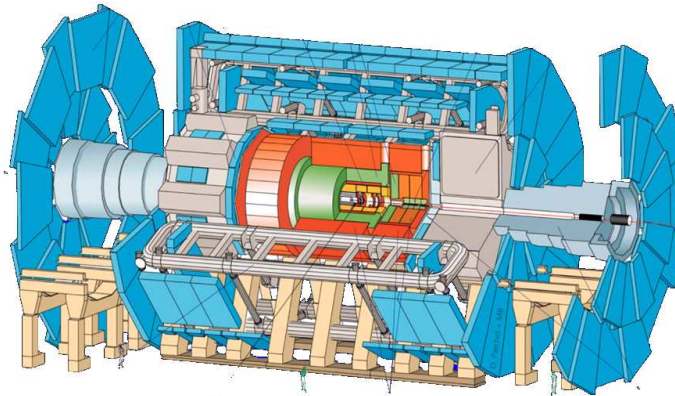

Figure 1.6: An impression of the ATLAS detector which is being assembled. This detector is 44 m long! Particles that are produced by proton collisions are measured using several detection techniques. NIKHEF contributes to the silicon tracking detectors and muon drift tube chambers. See www.cern.ch for more information.

In different textbooks you will find different notations. A common notation is:

$$\vec{E} = \sum_{i=1,N} \frac{1}{4\pi\epsilon_0} \frac{Q_i}{r_i^2} \hat{r}_i \quad (1.12)$$

In this case the vector \vec{r}_i is defined as $\vec{r}_i = \vec{r}_0 - \vec{r}_i$. Be aware of this freedom of notation, which leads to many un-necessary mistakes.

A way to physically interpret the above expression for the electrical field is that a charge q senses an electrical field and consequently undergoes a force $\vec{F} = q\vec{E}$. We have introduced the field as a relatively simple mathematical definition. However, the electrical field is a genuine physics quantity! In electrostatic theory, the field is present in space and you can calculate it using formula 1.11 when you know the (point) charge distribution. If the field is present in space, you may wonder, where is it made off? That is a bit harder to answer and beyond the scope of this course. In particle physics, fields consist of 'force particles' that are being exchanged when particles have an interaction. The electrical field consist of (virtual) photons that are exchanged between electrical charges.

Above, all equations are based on point charges. Since all charge are carried by individual particles this seems not unreasonable. However, in the classical theory charges can be continuously distributed. This is still reasonable when we describe physics at a scale much (much) larger than the size of and distances (10^{-10} m) between the particles. The classical theory describes nature in a macroscopic matter. We will discuss some examples of continuous charge distributions.

Line charge

A line charge can be described by a charge density $\lambda(\vec{r}_l)$ with has the unit C/m. The position vector \vec{r}_l is a coordinate defined with respect to some origin. To calculate the field in point P with coordinate \vec{r}_p , we integrate over the infinitesimal pieces of charge $\lambda(\vec{r}_l)dl$ to find the electrical field:

$$\vec{E}(\vec{r}_p) = \frac{1}{4\pi\epsilon_0} \int_{line} \frac{\lambda(\vec{r}_l)}{r^2} \hat{r} dl \quad (1.13)$$

where \vec{r} is the connection vector between a piece of charge and the point P with coordinate \vec{r}_P , thus $\vec{r} = \vec{r}_P - \vec{r}_l$. This is illustrated in Fig. 1.7.

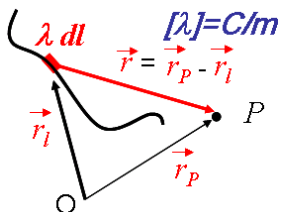

Figure 1.7: Illustration of a line charge.

In fact, we can still interpret the integral as the sum over point charges as we used to do in equation 1.11. A point charge is then just a piece of line charge $dq = \lambda(\vec{l})dl$ and so we obtain:

$$\begin{aligned}\vec{E}(\vec{r}_P) &= \frac{1}{4\pi\epsilon_0} \int_{charge} \frac{dq}{r^2} \hat{r} \\ &= \frac{1}{4\pi\epsilon_0} \int_{charge} \frac{dq}{|\vec{r}_P - \vec{r}_l|^2} \frac{\vec{r}_P - \vec{r}_l}{|\vec{r}_P - \vec{r}_l|} \\ &\approx \sum_{point\ charges} \frac{1}{4\pi\epsilon_0} \frac{Q_i}{|\vec{r}_P - \vec{r}_i|^2} \frac{\vec{r}_P - \vec{r}_i}{|\vec{r}_P - \vec{r}_i|}\end{aligned}\quad (1.14)$$

Perhaps the interpretation of a continuous charge distribution as a collection of point charges helps you to make the math less abstract.

Example of a line charge

As an example we will calculate the electrical field in a point P with $z = z_P$ of a piece of wire with length L centered on the x axis. The wire carries an uniform charge density λ . The configuration is shown in Fig. 1.8.

When we consider the contribution, $d\vec{E}$, of a piece of charge λdx at position x to the electrical field in P we see that there are two components, an x and z component:

$$\begin{aligned}dE_x &= \frac{1}{4\pi\epsilon_0} \frac{\lambda dx}{z_P^2 + x^2} \sin(\alpha) \\ dE_z &= \frac{1}{4\pi\epsilon_0} \frac{\lambda dx}{z_P^2 + x^2} \cos(\alpha)\end{aligned}\quad (1.15)$$

Look at the symmetry of this problem. The components in the x direction cancel ($E_x = 0$) and thus we only have to integrate the z contributions. So, we need to know $\cos(\alpha)$, which we can get from the figure (convince yourself!): $\cos(\alpha) = \frac{z_P}{\sqrt{z_P^2 + x^2}}$. Now we can integrate all contributions:

$$\begin{aligned}E_z &= \int dE_z \\ &= \int_{-L/2}^{+L/2} \frac{1}{4\pi\epsilon_0} \frac{\lambda dx}{z_P^2 + x^2} \frac{z_P}{\sqrt{z_P^2 + x^2}}\end{aligned}$$

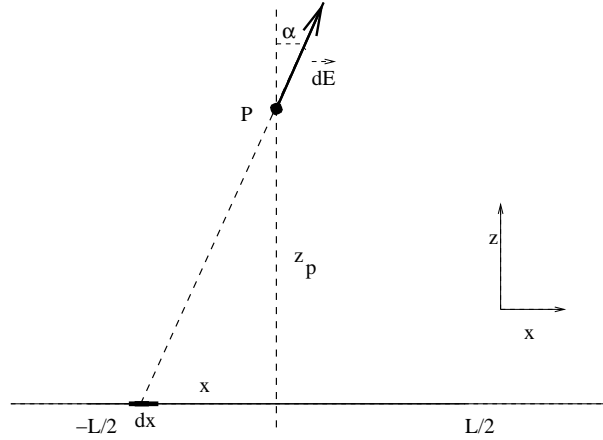

Figure 1.8: A wire of length L with uniform charge distribution. Also indicated is the contribution to the electrical field in point P of a piece of line dx .

$$\begin{aligned}
 &= \int_{-L/2}^{+L/2} \frac{1}{4\pi\epsilon_0} \frac{z_P \lambda dx}{(z_P^2 + x^2)^{3/2}} \\
 &= \frac{\lambda}{4\pi\epsilon_0} \frac{x}{z_P \sqrt{z_P^2 + x^2}} \Big|_{-L/2}^{+L/2} \\
 &= \frac{\lambda}{4\pi\epsilon_0} \frac{L}{z_P \sqrt{z_P^2 + (L/2)^2}} \quad (1.16)
 \end{aligned}$$

Does the result make sense? Well, we know that the field of a point charge is linear with charge Q and drops quadratically with the distance. If we look from very large distance to the line charge, $z_P \gg L$, so that all the charge on the line appears concentrated in a point, we find that

$$E_z = \frac{1}{4\pi\epsilon_0} \frac{\lambda L}{z_P^2} = \frac{1}{4\pi\epsilon_0} \frac{Q_{total}}{z_P^2} \quad (1.17)$$

which is the field of a point charge $Q_{total} = \lambda L$, as expected.

Surface charge

An illustration of a surface charge is depicted in Fig. 1.9. A surface charge is described by a charge density $\sigma(\vec{r}_s)$ with has the unit C/m^2 . When \vec{r}_s lies on the surface, $\sigma(\vec{r}_s)$ has some value that represents the charge density. When \vec{r}_s lies outside the surface, $\sigma(\vec{r}_s) = 0 C/m^2$. To calculate the electrical field we integrate over the contribution of the infinitesimal pieces of charge $dq = \sigma(\vec{r}_s)do$. The electrical field in point P is given by:

$$\vec{E}(\vec{r}_P) = \frac{1}{4\pi\epsilon_0} \int_{surface} \frac{\sigma(\vec{r}_s)}{r^2} \hat{r} do \quad (1.18)$$

Now \vec{r} is defined as the connection vector between point \vec{r}_P and the location of some infinitesimal piece of surface, thus $\vec{r} = \vec{r}_P - \vec{r}_s$.

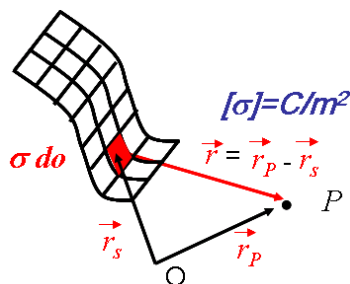
Figure 1.9: *Illustration of a surface charge.*

Like the integration over a line, the integration over a surface is a difficult task. Only in special cases we can actually perform the integration. So, don't worry for the moment if you do not see how in general you could use the above expression. Finally we remark that we have been 'sloppy' with our notation: a surface is two dimensional, thus one would expect a double integral with two integration variables. Well, get used to it: in different textbooks you will find at least as many different notations. Be prepared and just 'bluf' through it.

Volume charge

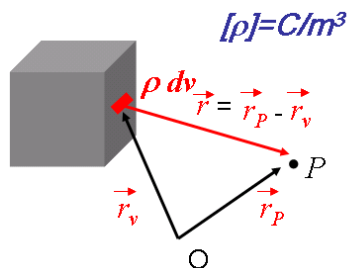
Figure 1.10: *Illustration of a volume charge.*

An illustration of a volume charge is depicted in Fig. 1.10. The volume charge density $\rho(\vec{r}_v)$ is the most general continuous charge density and has the unit C/m^3 . The contribution of the infinitesimal pieces of charge $dq = \rho(\vec{r}_v)dV$ lead to the following expression:

$$\vec{E}(\vec{r}_P) = \frac{1}{4\pi\epsilon_0} \int_{\text{volume}} \frac{\rho(\vec{r}_v)}{r^2} \hat{r} dV \quad (1.19)$$

Now \vec{r} is defined as the connection vector between point \vec{r}_P and the location of some infinitesimal piece of volume dV at position \vec{r}_v . Applications of this expression come later. Note that we again have been sloppy with the notation. A volume (in this report) has three dimensions and thus three integration variables. For example when we integrate a function f over a volume in Cartesian coordinates:

$$\int_{\text{volume}} f dV = \int_{x=-\infty}^{\infty} \int_{y=-\infty}^{\infty} \int_{z=-\infty}^{\infty} f(x,y,z) dx dy dz \quad (1.20)$$

and in spherical coordinates:

$$\int_{\text{volume}} f dv = \int_{\phi=0}^{2\pi} \int_{\theta=0}^{\pi} \int_{r=0}^{\infty} f(r, \phi, \theta) r^2 \sin(\theta) d\phi d\theta dr \quad (1.21)$$

If this is 'abracadabra' to you, first work through a textbook on mathematics¹.

1.2.3 Knowledge and Skills

The knowledge and skills you should have acquired during reading of the previous can be summarized as follows:

- Charge can be positive and negative. Electrons carry the elementary charge $-e$, with $e = 1.6002 \times 10^{-19}$ C. The total charge is conserved.
- The electrical or Coulomb force between two electrically charged objects is given by:

$$\vec{F} = \frac{1}{4\pi\epsilon_0} \frac{qQ}{r^2} \hat{r} \quad (1.22)$$

Make sure you understand the notation!

- The electrical field of a point charge q is given by:

$$\vec{E} = \frac{1}{4\pi\epsilon_0} \frac{q}{r^2} \hat{r} \quad (1.23)$$

- The electrical field of a volume charge is:

$$\vec{E}(\vec{r}_p) = \frac{1}{4\pi\epsilon_0} \int_{\text{volume}} \frac{\rho(\vec{r}_v)}{r^2} \hat{r} dv \quad (1.24)$$

You understand all the vectors in this notation and you can make a drawing that illustrates this expression. You can also write down the formulas for the electrical field of a line charge and a surface charge.

In addition, make the corresponding exercises of this section, which you can find in the Appendix.

1.3 Electrical flux and Gauss' Law

1.3.1 Electrical field lines and electrical flux

Figure 1.11 graphically displays the electrical field corresponding to the electrical field of a point charge. To make this drawing a grid was chosen and on each grid-point the electrical field is represented by an arrow. The length of the arrow corresponds to the magnitude of the field and, as can be seen in the figure, decreases quadratically as appropriate.

Traditionally, the electrical field is depicted by field lines as shown in Fig. 1.12. The density of the lines represent the magnitude of the field. Note that such drawings are two dimensional

¹Please, let the authors of this report know when integration using spherical coordinates are unknown to you at the time of the lectures. Don't hesitate! Additionally, in the slides that are discussed during the sessions, added as Appendix you can find more explanation and many examples.

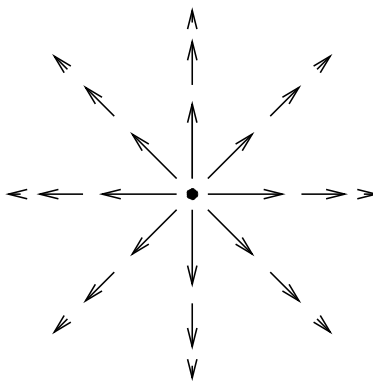

Figure 1.11: *The electrical field of a point charge depicted by vectors.*

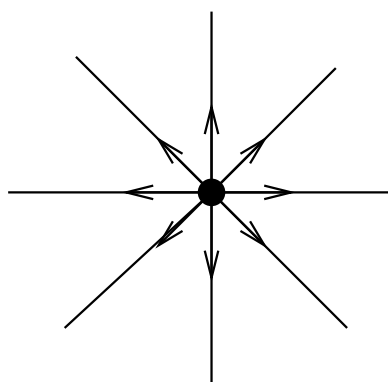

Figure 1.12: *The electrical field of a point charge depicted by field lines.*

projections and thus that the density of the lines drops with the circumference of a circle, $2\pi r$. In three dimensions the line-density drops with the surface of a sphere, $4\pi r^2$

Have another look to the field lines in Fig. 1.12 and imagine a spherical surface around a point charge. The number of field lines through the surface is constant, thus independent on the size (or better radius) of the sphere. You find an animation of this phenomena on the web-page.

The number of field lines can be expressed by the electrical flux:

$$\Phi = \int_{\text{surface}} \vec{E} \cdot d\vec{o} \quad (1.25)$$

This the flux through a surface. The infinitesimal surface element $d\vec{o}$ is a vector with magnitude do and its direction perpendicular to the surface. We can write

$$\vec{E} \cdot d\vec{o} = \vec{E} \cdot \hat{n} do = |\vec{E}| \cos(\phi) do \quad (1.26)$$

with \hat{n} the normal on the surface² and ϕ represents the angle between the electrical field and normal direction of the surface.

Figure 1.13 shows three examples of the electrical flux through a surface for different angles between the field and surface. With the electrical field being constant, the flux through each surface

²In textbooks several notations are used for the normal vector, a few common notations are: $\hat{n} = \vec{n} = \vec{e}_n = \hat{e}_n$.

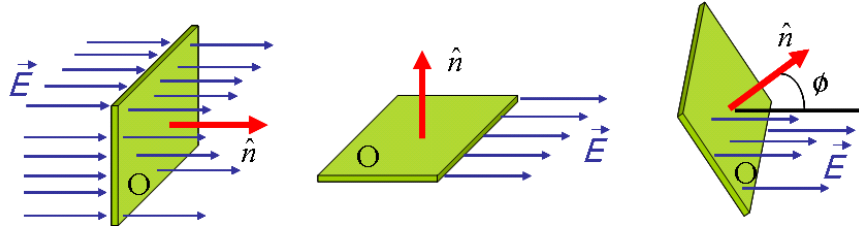

Figure 1.13: The electrical flux through a surface S for different angles between the field and surface. The normal \hat{n} is also indicated.

S in Fig. 1.13a-c is:

$$\begin{aligned}
 \text{a: } \Phi_S &= |\vec{E}| \cos(0) S = |\vec{E}| S \\
 \text{b: } \Phi_S &= |\vec{E}| \cos(\pi/2) S = 0 \\
 \text{c: } \Phi_S &= |\vec{E}| \cos(\phi) S
 \end{aligned} \tag{1.27}$$

1.3.2 Gauss' Law

Gauss' Law states that the electrical flux through a closed surface, independent of its shape, equals the total charge enclosed by this surface multiplied by the factor $\frac{1}{\epsilon_0}$. Thus:

$$\Phi = \oint_{\text{closed-surface}} \vec{E} \cdot d\vec{o} = \sum_{\text{charges-enclosed}} \frac{Q_i}{\epsilon_0} \tag{1.28}$$

The circle in the integral symbol \oint indicates that you have to integrate over a closed surface, without skipping any parts. As in many textbook, we often use the normal symbol, \int , and mention specifically whether the integral runs over a full or restricted domain.

The relation above allows us to calculate the electrical field in many cases in an remarkable elegant way. But first we will deduce, or better, verify the validity of Gauss' Law for a simple case. Therefore we consider a point charge, Q , and calculate the electrical flux through a spherical surface with radius R . This configuration is illustrated in Fig. 1.14. The flux is given by:

$$\Phi = \int_{\text{surface}} \vec{E} \cdot d\vec{o} = \int_{\text{surface}} \vec{E} \cdot \hat{n} do \tag{1.29}$$

where \hat{n} is the normal vector on the surface. Now we use the argument that on sphere, both \vec{E} and \hat{n} point in the radial direction, hence

$$\Phi = \int_{\text{surface}} |\vec{E}| \cos(\alpha_{\vec{E}, \hat{n}}) do = \int_{\text{surface}} |\vec{E}| do \tag{1.30}$$

The electrical field at the surface follows from equation 1.11, $|\vec{E}| = E_r(R) = \frac{1}{4\pi\epsilon_0} \frac{Q}{R^2}$. We find

$$\begin{aligned}
 \Phi &= \frac{1}{4\pi\epsilon_0} \frac{Q}{R^2} \int_{\text{surface}} do \\
 &= \frac{1}{4\pi\epsilon_0} \frac{Q}{R^2} 4\pi R^2 \\
 &= \frac{Q}{\epsilon_0}
 \end{aligned} \tag{1.31}$$

independent of the location on the surface, in accordance with Gauss' Law.

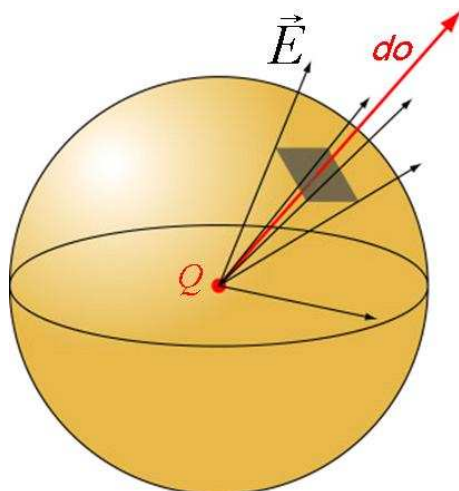

Figure 1.14: Illustration of the electrical flux from a point charge Q through a spherical surface S . Everywhere, the electrical field points along the normal on the surface, i.e. the radial direction. Some infinitesimal piece of surface do on the sphere is also indicated.

Intermezzo: a more mathematical approach

To evaluate (i.e. to get rid off) the dot-product $\vec{E} \cdot d\vec{o}$ we used the argument that both vectors point in the radial direction. Perhaps this step is hard to digest and you want to see what is behind it. Well, let's give it a try. If we had started using Cartesian coordinates we would have written:

$$\begin{aligned}\Phi &= \int_{\text{surface}} \vec{E} \cdot d\vec{o} \\ &= \int_{\text{surface}} (E_x \hat{x} + E_y \hat{y} + E_z \hat{z}) \cdot (n_x \hat{x} + n_y \hat{y} + n_z \hat{z}) do\end{aligned}\quad (1.32)$$

with $\hat{n} = (n_x, n_y, n_z)$ the normal vector on the spherical surface. The unit vectors in the x , y and z direction are represented as \hat{x} , \hat{y} and \hat{z} respectively. Another common notation for these unit vectors are \hat{i} , \hat{j} and \hat{k} .

The expression in Cartesian coordinates is for our case just terrible because the physical symmetry of the original problem is obscured. Obviously we need to work in spherical coordinates. Then, formally we obtain:

$$\begin{aligned}\Phi &= \int_{\text{surface}} \vec{E} \cdot d\vec{o} \\ &= \int_{\text{surface}} (E_\phi \hat{\phi} + E_\theta \hat{\theta} + E_r \hat{r}) \cdot (n_\phi \hat{\phi} + n_\theta \hat{\theta} + n_r \hat{r}) do \\ &= \int_{\text{surface}} (E_\phi n_\phi \hat{\phi} + E_\theta n_\theta \hat{\theta} + E_r n_r \hat{r}) do\end{aligned}\quad (1.33)$$

With $\hat{\phi}$, $\hat{\theta}$ and \hat{r} the unit direction vectors in the ϕ , θ and r direction respectively. It looks abstract, (it is), but just try to see through the notation and realize that the vectors are written out in components.

We then use $\vec{E} = (0\hat{\phi}, 0\hat{\theta}, E_r \hat{r})$ with $E_r = \frac{Q}{4\pi\epsilon_0 r^2}$. In fact E_r is a function and depends in general on \vec{r} or in this case for a point charge just on r . Hence, on the surface $E_r = E_r(r = R)$. The normal

vector \hat{n} on the surface points in the radial direction and has the unit length: $\hat{n} = (0, 0, \hat{r})$. When we substitute these expressions and reshuffle, we acquire:

$$\begin{aligned}
 \Phi &= \int_{surface} \frac{1}{4\pi\epsilon_0} \frac{Q}{R^2} do \\
 &= \frac{1}{4\pi\epsilon_0} \frac{Q}{R^2} \int_{\phi=0}^{2\pi} \int_{\theta=0}^{\pi} R^2 \sin(\theta) d\phi d\theta \\
 &= \frac{1}{4\pi\epsilon_0} \frac{Q}{R^2} R^2 \int_{\theta=0}^{\pi} (\phi)|_0^{2\pi} \sin(\theta) d\theta \\
 &= \frac{1}{4\pi\epsilon_0} \frac{Q}{R^2} R^2 2\pi (-\cos(\theta))|_0^{\pi} \\
 &= \frac{1}{4\pi\epsilon_0} \frac{Q}{R^2} R^2 4\pi \\
 &= \frac{Q}{\epsilon_0}
 \end{aligned} \tag{1.34}$$

Probably this intermezzo did not increase your confidence in Gauss' Law. It showed however the basic steps which many textbooks tend to skip. In the following we often skip such steps; they contain too much mathematical detail and so distract from our physics case. What was the physics case? Well, the symmetry in the behavior of the electrical field, namely the $1/r^2$ dependence, and that of the size of the spherical surface growing with r^2 leads to a cancellation.

1.3.3 Validity of Gauss' Law

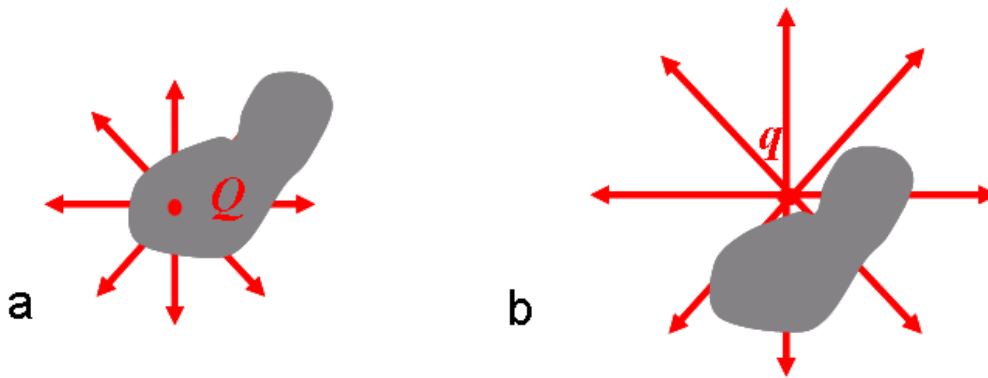

Figure 1.15: (a) Point charge Q in a closed surface. (b) Point charge Q outside a closed surface.

We checked Gauss' Law for a spherical surface with a point charge located at its center. Figure 1.15a shows a weird shaped closed surface with a point charge somewhere in its volume. Also for this shape Gauss' Law is valid; it is the 'dot' product which does the job. Put the point charge in the origin. Its electrical field has only radial components. The dot-product with the normal vector of the surface kills all non-radial contributions. In addition, the distance of the surface with respect to the charge is irrelevant: the field drops with $1/r^2$ and the radial projection of the surface grows with r^2 . Also, we could have put many point charge at different location within the closed surface. Obviously for each point charge individually the contribution to the flux is its charge (divided by ϵ_0), and the total flux is given by the sum of all charges ($/\epsilon_0$).

Figure 1.15b shows a closed surface with a charge located outside its volume. Use the above arguments to deduce (qualitatively) that $\Phi = 0$ in this case.

1.3.4 Applications of Gauss's law

'Gauss' Law is always valid, but not always useful'. What does this mean? Well, Gauss' Law can be applied in some cases to evaluate the electrical field in an elegant way. Below, we describe a few of these configurations.

The line charge

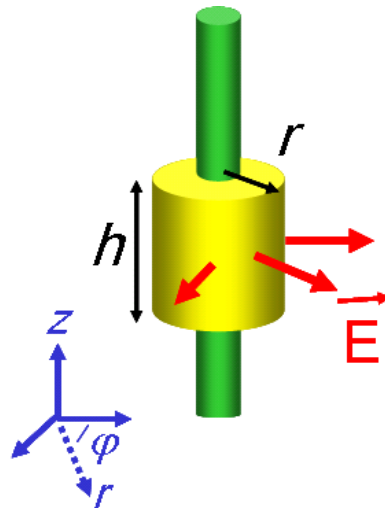

Figure 1.16: A line charge (dark gray). A Gaussian cylinder (light gray) with height h and radius r is also drawn.

Figure 1.16 shows an infinitely long and infinitely thin line charge with uniform charge density λ . The optimal Gaussian surface is a cylinder. To obtain this insight, first deduce the shape of the electrical field. It needs some practice to acquire a feeling for this, but we can give some hints.

- Imagine the line is build from small point charges $d\lambda$. Every point charge produces a electrical field point in the radial (spherical-wise) direction. Consider a position somewhere near the line. At this position you 'feel' an equal amount of field lines from above as from below. Hence, the field in the z direction cancels. Obviously there are no components in the ϕ direction. There can only be a component pointing away from the line charge.
- Look at the symmetry of the line charge. Suppose there is a field component in the z direction. Remember that the line is infinitely long and imagine that you mirror the configuration in the $r\phi$ plane. This does not change the physical configuration, but the 'would be' z component of the field has changed sign. There is only one possibility: there is no z component.

We conclude that the electrical field has only a radial (cylinder-wise) component. Therefore we try a cylindrical Gaussian surface with arbitrary height h and radius r . The flux through the cylinder is

given by the sum of the contributions of the curved body and the ends:

$$\Phi = \oint_{cylinder} \vec{E} \cdot d\vec{o} = \int_{ends} \vec{E} \cdot d\vec{o} + \int_{curved-body} \vec{E} \cdot d\vec{o} \quad (1.35)$$

The normal vector on the ends of the cylinder point (only) in the z direction. Hence, the dot-product filters out the z component of the electrical field, which is zero. So, we are left with the contribution of the flux through the curved body of the cylinder. The normal vector is radial (cylinder-wise) and thus filters out the one and only radial component of the electrical field, ($E_r(r)$). We obtain:

$$\Phi = \int_{curved-body} \vec{E} \cdot d\vec{o} = \int_{curved-body} E_r(r) do = \int_{\phi=0}^{2\pi} \int_{z=0}^{z=h} E_r(r) dzrd\phi \quad (1.36)$$

The electrical field is independent on the integration variables and we may write:

$$\Phi = E_r(r) \int_{\phi=0}^{2\pi} \int_{z=0}^{z=h} dzrd\phi = E_r(r) 2\pi rh \quad (1.37)$$

Now we apply Gauss' Law:

$$\Phi = E_r(r) 2\pi rh = \frac{Q_{enclosed}}{\epsilon_0} = \frac{\lambda h}{\epsilon_0} \quad (1.38)$$

For the electrical field of a line charge we find that:

$$\begin{aligned} E_z &= 0 \\ E_\phi &= 0 \\ E_r(r) &= \frac{\lambda}{2\pi\epsilon_0 r} \end{aligned} \quad (1.39)$$

If the line has a finite length L this method can not be applied. However, it then still provides a good estimate of the field close to the wire, i.e. $r \ll L$. If you are not convinced, use the result of the direct integration in Section 1.2.2 to show this. Also when the charge density is not constant in the z direction we can not simply apply Gauss' law. When the line has a finite thickness with radius ρ this method can still be applied as we will see later.

A flat surface charge

Figure 1.17 shows an, infinitely large and infinitely thin, surface charge with uniform charge density σ . What are the components of the electrical field?

- Imagine the plate constituted of small point charges $d\sigma = \sigma do$. Every point charge produces an electrical field point in the radial (spherical-wise) direction. Consider a position somewhere near the plate. At this position you 'feel' an equal amount of field lines from above as from below and from left as from right. Hence, the field in the x and z direction is zero. There can only be a component perpendicular to the surface charge.
- We can also used arguments based on symmetry. Suppose there is a field component in the x and/or z direction. Turn the configuration around its y axis. The plate is infinitely large and thus remains physically the same. The would be components would have changed direction, while the physics is invariant.

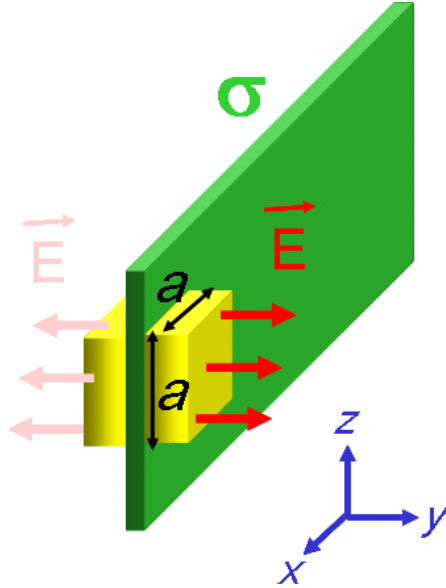

Figure 1.17: A flat surface charge (dark-gray). A Gaussian cubical surface is also indicated.

- In addition, a shift of the plate in the $x - z$ plane does not change the electrical configuration. This implies that the electrical field does not depend on x or z and thus only depends on y .

We conclude that the electrical field has only a component in the y direction, opposite for the region $\pm y$. We try a cubical Gaussian surface (a pill-box) with ribs sized a . The flux through the sides with normal vector in the x and z direction is zero. We only need to calculate the flux through the top-covers with normal vector in the y direction. The normal vector in the $-y$ region is opposite to that in the $+y$ region, but the electrical field direction also swaps. Hence,

$$\Phi = \int_{\text{top-covers}} \vec{E} \cdot d\vec{o} = 2 \int_{\text{top-cover}} E_y(y) do = 2a^2 E_y(y) \quad (1.40)$$

Make sure you understand the steps above. From Gauss' Law follows

$$\Phi = 2E_y(y)a^2 = \frac{Q_{\text{enclosed}}}{\epsilon_0} = \frac{a^2\sigma}{\epsilon_0} \quad (1.41)$$

And for the size of the electrical field we obtain $E_y = \frac{\sigma}{2\epsilon_0}$ and thus

$$\vec{E} = \frac{\sigma}{2\epsilon_0} \hat{y}. \quad (1.42)$$

Note that the field is constant, but point in the opposite direction for positive and negative y values respectively.

In general, thus for non-uniform charge densities this method cannot be used, unless it is known that the electrical field has only a \hat{y} component. Then, the result will look like $\vec{E}(x, z) \sim \sigma(x, z)\hat{y}$.

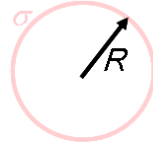

Figure 1.18: Illustration of a spherical surface charge density σ with radius R .

A spherical surface charge

We consider a spherical charged surface (or shell) with radius R and surface charge density σ as illustrated in Fig 1.18.

What are the components of the electrical field? Suppose there are non-radial (spherical-wise) components. Rotate the configuration around its center such that the non-radial components change direction. Realize that the physical configuration is invariant allowing no non-radial components. The same argument can be used to deduce that the radial component of the field only depends on r . Hence, $\vec{E} = E_r(r)\hat{r}$. We did not specify whether we discussed the field inside or outside the shell. Well, it doesn't matter. Both inside and outside the shell we can use the above arguments.

For the electrical flux inside the shell follows:

$$\Phi = \int_{\text{spherical-surface}} \vec{E} \cdot d\vec{o} = E_r(r) \int_{\text{spherical-surface}} do = E_r(r)4\pi r^2 \quad (1.43)$$

There is no enclosed charge, so we have:

$$\Phi = E_r(r)4\pi r^2 = 0 \quad (1.44)$$

There is only one possibility: $E(r) = 0$ inside the surface.

Outside the shell, $r > R$, we find the same expression for the flux. The enclosed charge is $Q = \int_{\text{surface}} \sigma do = \sigma 4\pi R^2$. We obtain:

$$\Phi = E_r(r)4\pi r^2 = \frac{1}{\epsilon_0} \sigma 4\pi R^2 \quad (1.45)$$

For the electrical field follows

$$\vec{E} = E_r(r)\hat{r} = \frac{\sigma R^2}{\epsilon_0 r^2} \hat{r} \quad r > R \quad (1.46)$$

In fact, the electrical field outside the shell is identical to that of a point charge in the center with the same charge as present on the shell. This can be easily shown. We substitute $\sigma = \frac{Q}{4\pi R^2}$ in equation 1.46 and find:

$$\vec{E} = \frac{Q}{4\pi\epsilon_0 r^2} \hat{r} \quad (1.47)$$

which is the field of a point charge, as expected.

A massive spherical charge

Figure 1.19 shows a spherical volume charge density ρ . The volume has radius R . Like in the previous example, we have spherical symmetry. The electrical field has only a radial component and depends only on the radial distance: $\vec{E} = E_r(r)\hat{r}$.

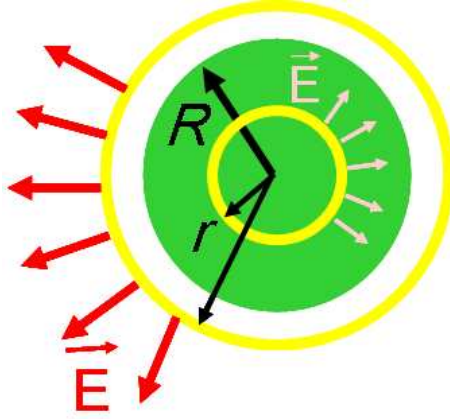

Figure 1.19: A spherical volume with radius R carrying a uniform charge density ρ (dark-gray). Two Gaussian spherical surfaces are indicated. One inside and one outside the charge density.

The electrical flux outside the sphere, $r > R$, is given by:

$$\Phi = \int_{\text{spherical-surface}} \vec{E} \cdot d\vec{o} = E_r(r) \int_{\text{spherical-surface}} do = E_r(r) 4\pi r^2 \quad (1.48)$$

Outside the spherical charge the enclosed charge is $\int_{\text{volume}} \rho dv = \rho \frac{4}{3} \pi R^3$. For the electrical field we find:

$$\vec{E} = \frac{\rho R^3}{3\epsilon_0 r^2} \hat{r} \quad r > R \quad (1.49)$$

Inside the spherical charge, $r < R$, we have in principal two contributions to the electrical field. One contribution from the inner sphere (surrounded by the Gaussian surface) with radius r and a contribution of the shell between r and R . In the previous section we calculated that the electrical field contribution inside a charged shell is zero. This implies that we only have to account for the contribution from the inner sphere. The Gaussian spherical surface encloses a charge $\rho \frac{4}{3} \pi r^3$. For the electrical flux we find:

$$E_r(r) 4\pi r^2 = \frac{\rho}{\epsilon_0} \frac{4}{3} \pi r^3 \quad (1.50)$$

This leads to an electrical field of

$$\vec{E} = \frac{\rho r}{3\epsilon_0} \hat{r} \quad r < R \quad (1.51)$$

Figure 1.20 shows the magnitude of the electrical field as function of r . Starting from the center, the field grows linearly with r till the surface of the spherical charge is reached. Then it drops with $1/r^2$, similar to the field of a point charge in the origin.

1.3.5 Knowledge and Skills

The knowledge and skills you should have acquired during reading of the previous can be summarized as follows:

- Gauss' Law:

$$\int_{\text{closed-surface}} \vec{E} \cdot d\vec{o} = \sum_{\text{charge-enclosed}} \frac{Q_i}{\epsilon_0} = \frac{1}{\epsilon_0} \int_{\text{volume}} \rho dv \quad (1.52)$$

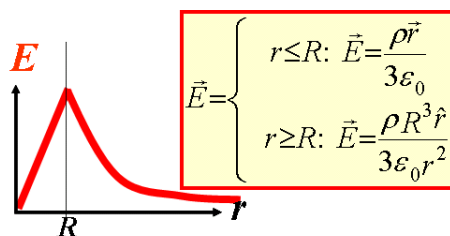

Figure 1.20: The size of the electrical field of a spherical uniform charge density as function of r .

which is always valid.

- In electrical configuration with a symmetry between the field and the charge distribution, Gauss' Law can be used to determine the electrical field.
- You can apply Gauss' Law for a line, flat surface, and spherical charge. You know how to use Cartesian, cylinder and spherical coordinates to perform surface and volume integrals.

In addition, make the corresponding exercises of this section, which you can find in the Appendix.

1.4 More on electrical field equations

Gauss' Law is a so called field equation. It uses an (surface) integral and is therefore called an integral equation. There exists also a differential form of this law, which we derive in this section.

However, Gauss' Law does not specify all properties of the electrical field. One more field equation is required. The integral form of the second field equation is based on the loop integral of the electrical field as we will see below.

1.4.1 Flux and divergence

The divergence of the electrical field is defined as

$$\vec{\nabla} \cdot \vec{E} = (\partial_x, \partial_y, \partial_z) \cdot (E_x, E_y, E_z) = \frac{\partial E_x}{\partial x} + \frac{\partial E_y}{\partial y} + \frac{\partial E_z}{\partial z} \quad (1.53)$$

We will introduce this quantity in a natural way and describe its link with Gauss' Law.

Figure 1.21 shows a infinitesimally small box, which is placed in an unspecified electrical field $\vec{E}(x, y, z)$. We work in Cartesian coordinates and calculate the electrical flux through the box. The flux $\int_{cover} \vec{E} \cdot d\vec{o}$ through each of the covers a to f of the box is given by:

$$\begin{aligned} \text{a:} & \quad -E_x(x, y, z) dydz \\ \text{b:} & \quad E_x(x + dx, y, z) dydz \\ \text{c:} & \quad -E_y(x, y, z) dx dz \\ \text{d:} & \quad E_y(x, y + dy, z) dx dz \\ \text{e:} & \quad -E_z(x, y, z) dx dy \\ \text{f:} & \quad E_z(x, y, z + dz) dx dy \end{aligned} \quad (1.54)$$

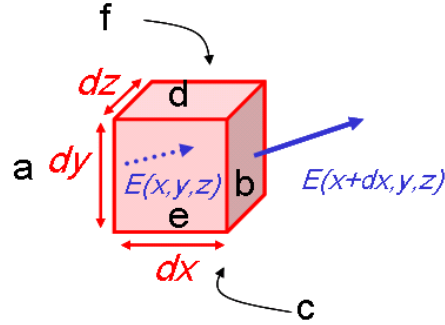

Figure 1.21: An infinitesimal box with volume $= dx dy dz$ in an electrical field $\vec{E}(x, y, z)$. The covers a to f are indicated. Also, the field vectors on cover a and b are shown.

where $E_x(x, y, z)$ and so on are defined on the centre of the corresponding cover. Note the relative minus sign for opposite covers which comes from the opposite direction of the normal vectors on these covers. Now we add all contributions to obtain the flux through the box:

$$\begin{aligned} \int_{\text{box}} \vec{E} \cdot d\vec{o} &= [E_x(x+dx, y, z) - E_x(x, y, z)] dy dz \\ &\quad [E_y(x, y+dy, z) - E_y(x, y, z)] dx dz \\ &\quad [E_z(x, y, z+dz) - E_z(x, y, z)] dx dy \end{aligned} \quad (1.55)$$

Remember the rule of elementary calculus that $df = f(x+dx) - f(x)$. The above equation can be rewritten as:

$$\int_{\text{box}} \vec{E} \cdot d\vec{o} = dE_x dy dz + dE_y dx dz + dE_z dx dy \quad (1.56)$$

Now multiply the part with E_x , E_y and E_z with $\frac{dx}{dx}$, $\frac{dy}{dy}$ and $\frac{dz}{dz}$ respectively, which is (for physicists) mathematically equivalent to multiplying with unity. We find

$$\begin{aligned} \int_{\text{box}} \vec{E} \cdot d\vec{o} &= \frac{dE_x}{dx} dx dy dz + \frac{dE_y}{dy} dx dy dz + \frac{dE_z}{dz} dx dy dz \\ &= \left[\frac{dE_x}{dx} + \frac{dE_y}{dy} + \frac{dE_z}{dz} \right] dx dy dz \\ &= \vec{\nabla} \cdot \vec{E} \text{ volume}_{\text{box}} \end{aligned} \quad (1.57)$$

Hence, we derived a relation between the flux through infinitesimal box and the divergence of the electrical field. The relation is however valid for any volume. To see this, glue boxes together to make you any volume as illustrated in Fig. 1.22. We obtain:

$$\int_{\text{surface}} \vec{E} \cdot d\vec{o} = \int_{\text{volume}} [\vec{\nabla} \cdot \vec{E}] dv \quad (1.58)$$

Although we derived this expression for the electric field, it is valid for any vector field and was first derived by Gauss. We will refer to this expression as Gauss' Theorem.

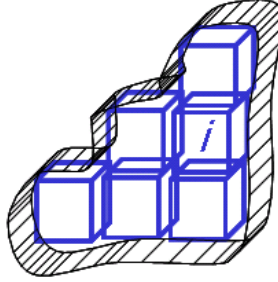

Figure 1.22: Any volume consists of a collection of infinitesimal boxes.

1.4.2 Gauss' Law and Gauss' Theorem

Gauss' Law for the electrical flux:

$$\int_{\text{surface}} \vec{E} \cdot d\vec{\sigma} = \frac{1}{\epsilon_0} Q_{\text{enclosed}} = \frac{1}{\epsilon_0} \int_{\text{volume}} \rho dv \quad (1.59)$$

can be combined with Gauss' theorem:

$$\int_{\text{surface}} \vec{E} \cdot d\vec{\sigma} = \int_{\text{volume}} \vec{\nabla} \cdot \vec{E} dv \quad (1.60)$$

This leads to the following expression:

$$\int_{\text{surface}} \vec{E} \cdot \vec{\sigma} = \int_{\text{volume}} \vec{\nabla} \cdot \vec{E} dv = \frac{1}{\epsilon_0} \int_{\text{volume}} \rho dv \quad (1.61)$$

which implies

$$\vec{\nabla} \cdot \vec{E} = \frac{\rho}{\epsilon_0} \quad (1.62)$$

This relation is Gauss' Law in differential form. It locally relates the charge density and the electrical field.

1.4.3 Gauss' Law for a charged sphere

Given the electrical field, we can 'simply' determine the charge density using Gauss' Law (in differential form). We start with the known field of a uniformly charged sphere with density ρ . The electrical field inside the sphere is:

$$\vec{E} = \frac{\rho r}{3\epsilon_0} \hat{r} = \frac{\rho}{3\epsilon_0} \vec{r} \quad r < R \quad (1.63)$$

Now take the divergence.

$$\vec{\nabla} \cdot \vec{E} = \frac{\rho}{3\epsilon_0} \vec{\nabla} \cdot \vec{r} = \frac{\rho}{3\epsilon_0} (\partial_x, \partial_y, \partial_z) \cdot (x, y, z) \quad (1.64)$$

$$= \frac{\rho}{3\epsilon_0} (\partial_x x + \partial_y y + \partial_z z) = \frac{\rho}{3\epsilon_0} 3 = \frac{\rho}{\epsilon_0} \quad (1.65)$$

Yes!

Outside the charge sphere $\rho = 0$, the electrical field is $\vec{E} = \frac{\rho R^3}{3\epsilon_0 r^3} \vec{r}$. We calculate the divergence of $\frac{\vec{r}}{r^3}$:

$$\begin{aligned}
 \vec{\nabla} \cdot \frac{\vec{r}}{r^3} &= \vec{\nabla} \cdot \left[\frac{1}{(x^2 + y^2 + z^2)^{\frac{3}{2}}} (x, y, z) \right] \\
 &= \vec{\nabla} \cdot \left(\frac{x}{(x^2 + y^2 + z^2)^{\frac{3}{2}}}, \frac{y}{(x^2 + y^2 + z^2)^{\frac{3}{2}}}, \frac{z}{(x^2 + y^2 + z^2)^{\frac{3}{2}}} \right) \\
 &= \frac{\partial}{\partial x} \frac{x}{(x^2 + y^2 + z^2)^{\frac{3}{2}}} + \frac{\partial}{\partial y} \frac{y}{(x^2 + y^2 + z^2)^{\frac{3}{2}}} + \frac{\partial}{\partial z} \frac{z}{(x^2 + y^2 + z^2)^{\frac{3}{2}}} \\
 &= \left[\frac{\partial x}{\partial x} \right] \frac{1}{(x^2 + y^2 + z^2)^{\frac{3}{2}}} + x \left[\frac{\partial}{\partial x} \frac{1}{(x^2 + y^2 + z^2)^{\frac{3}{2}}} \right] + \partial_y \dots + \partial_z \dots \\
 &= 1 \frac{1}{(x^2 + y^2 + z^2)^{\frac{3}{2}}} + x \left[-\frac{3}{2} 2x \frac{1}{(x^2 + y^2 + z^2)^{\frac{5}{2}}} \right] + \partial_y \dots + \partial_z \dots \\
 &= \frac{3}{(x^2 + y^2 + z^2)^{\frac{3}{2}}} - 3(x^2 + y^2 + z^2) \frac{1}{(x^2 + y^2 + z^2)^{\frac{5}{2}}} \\
 &= 0
 \end{aligned} \tag{1.66}$$

Not convinced? Try it yourself!

1.4.4 The loop integral of the electrical field

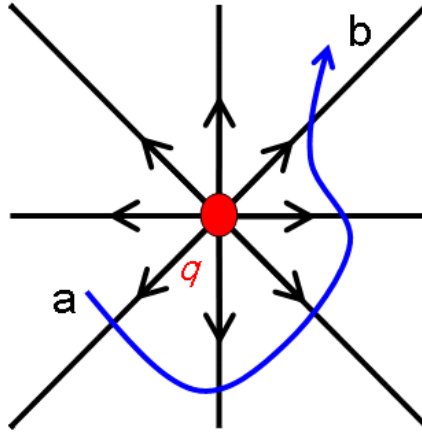

Figure 1.23: An illustration of a path integral in the electrical field of a point charge q .

Another important characteristic of the electric field emerges when we consider the path integral of the field of a point charge q :

$$\int_a^b \vec{E} \cdot d\vec{l} = \frac{q}{4\pi\epsilon_0} \int_a^b \frac{1}{r^2} \hat{r} \cdot d\vec{l} = \int_a^b E_r \hat{r} \cdot d\vec{l} \tag{1.67}$$

The electrical field is pointing purely radially. No matter what the exact path is followed from a to b , the dot-product filters out the radial component ($\hat{r} \cdot d\vec{l} = dr$). Thus we can replace the path

integral by:

$$\int_{r_a}^{r_b} E_r \cdot dr = \frac{q}{4\pi\epsilon_0} \int_{r_a}^{r_b} \frac{1}{r^2} dr = \frac{q}{4\pi\epsilon_0} \left. \frac{-1}{r} \right|_{r_a}^{r_b} = \frac{q}{4\pi\epsilon_0} \left(\frac{1}{r_a} - \frac{1}{r_b} \right) \quad (1.68)$$

For a closed path $r_a = r_b$ we obtain:

$$\int \vec{E} \cdot d\vec{l} = 0 \quad (1.69)$$

Thus, independent of the path we followed, the integral of a closed path of the electric field is zero. Using the superposition principle we can argue that this relation derived for a point charge is valid for any charge density.

The expression $\int \vec{E} \cdot d\vec{l} = 0$ is the second electrical field equation in integral form and has no historical name. The differential form $\vec{\nabla} \times \vec{E} = \vec{0}$ we will derive later.

1.4.5 Knowledge and Skills

The knowledge and skills you should have acquired during reading of the previous can be summarized as follows:

- You understand Gauss' theorem and the relation between the electrical field and the charge density:

$$\int_{surface} \vec{E} \cdot \vec{\sigma} = \int_{volume} \vec{\nabla} \cdot \vec{E} dv = \frac{1}{\epsilon_0} \int_{volume} \rho dv \quad (1.70)$$

- You can apply the field equation:

$$\vec{\nabla} \cdot \vec{E} = \frac{\rho}{\epsilon_0} \quad (1.71)$$

which is Gauss' Law in differential form.

- You can derive and use the loop integral of the electrical field:

$$\int \vec{E} \cdot d\vec{l} = 0, \quad (1.72)$$

independent of the path we followed.

In addition, make the corresponding exercises of this section, which you can find in the Appendix.

1.5 The electric potential

In this Section we will introduce the electric potential. It turns out that the electric potential is a powerful quantity to calculate the electric field of complex charge configurations. However, within the scope of this report we have to limit to more straightforward but elegant examples.

1.5.1 Work in a gravitational field

To refresh your memory we first consider work and potential energy in a gravitational field. The work, W_{person} when you lift an object with mass m from the ground to height h is

$$W_{person} = \int_0^h \vec{F} \cdot d\vec{l} \quad (1.73)$$

with the force, $|\vec{F}| = mg$, the mass times the gravitational constant. To lift the object we need to apply a force $\vec{F} = -\vec{F}_G = mg\hat{l}$ and thus the the total amount of work needed is:

$$W_{person} = mgh \quad (1.74)$$

The potential energy of the object equals $U = W_{person} = mgh$. In the following Section we apply this principle to the electrical field.

1.5.2 Potential energy in an electric field

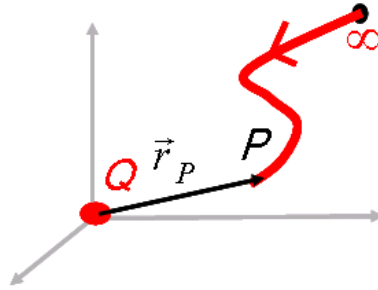

Figure 1.24: A test charge q in the field of a source charge Q is brought in from infinity to P .

Consider a (test) charge q in the electrical field of a point charge Q at position P , see also Fig. 1.24. The electrical force on the test charge is $\vec{F}_{elec} = q\vec{E}$. The (minimum) force you must exert on q to move it opposite to the electrical field is $-q\vec{E}$. The potential energy of the configuration is defined as the minimal work needed (for you) to bring the test charge q from infinity to P .

$$U_P = W_{person} = - \int_{\infty}^P q\vec{E} \cdot d\vec{l} \quad (1.75)$$

It must be emphasized that the path followed $d\vec{l}$ in principle has a radial and non radial components (the $\hat{\phi}$ and $\hat{\theta}$ direction). However, as before we argue that the electrical field has only a radial component and we can write:

$$U_P = -q \int_{\infty}^P \vec{E} \cdot d\vec{l} = -q \int_{\infty}^P E_r \hat{r} \cdot d\vec{l} = -q \int_{\infty}^{P=r_P} E_r dr \quad (1.76)$$

Now substitute the electrical field of a point charge and obtain:

$$U_P = \frac{-qQ}{4\pi\epsilon_0} \int_{\infty}^{r_P} \frac{1}{r^2} dr = \frac{qQ}{4\pi\epsilon_0} \frac{1}{r} \Big|_{\infty}^{r_P} = \frac{qQ}{4\pi\epsilon_0} \frac{1}{r_P} \quad (1.77)$$

A definition of the 'potential' V is the potential energy of a charge unit in the field of the source charge Q :

$$V_P = \frac{U_P}{q} = \frac{Q}{4\pi\epsilon_0} \frac{1}{r_P} \quad (1.78)$$

where the reference point or 'gauge-point' is implicitly taken at infinity.

To calculate the potential for a collection of charge, we simply extend equation 1.78 and integrate over all point charges in the collection:

$$V_P = \int_{charge} \frac{dq}{4\pi\epsilon_0 r} \quad (1.79)$$

and for a continuous charge density ρ we write:

$$V_P = \int_{volume} \frac{\rho(r)}{4\pi\epsilon_0 r} d\vec{r} \quad (1.80)$$

1.5.3 The definition of the electric potential

The most general definition of the potential is

$$V_P = - \int_{gauge}^P \vec{E} \cdot d\vec{l} \quad (1.81)$$

where the gauge-point can be chosen where-ever you want. You can verify yourself that for a point charge and gauge-point at infinity you find back equation 1.78.

We have defined the potential starting the potential energy of a simple charge configuration. Fine, the potential and the potential energy are related; that is useful to know. But, what about the general definition of the potential? It depends in general on the free choice of a gauge-point. How can such freedom be useful for describing physics? Indeed, the potential itself has no physical interpretation. However, potential difference and as we will see soon, the gradient of the potential are relevant physics quantities.

1.5.4 The potential and the electrical field

From the previous section we know how to calculate the potential from the electrical field. Is it also possible to determine the electrical field given the potential. To find this relation, consider the difference in potential between points A and B :

$$V_{AB} = V_B - V_A = \int_B^\infty \vec{E} \cdot d\vec{l} - \int_A^\infty \vec{E} \cdot d\vec{l} = - \int_A^B \vec{E} \cdot d\vec{l} \quad (1.82)$$

where we swapped the upper and lower boundary of the integral, so keep track of the 'plus and minus' signs! Note that the potential difference V_{AB} is uniquely defined, independent of the gauge-point.

The potential is just a scalar function. Hence,

$$\begin{aligned} V_B - V_A = \int_A^B dV &= \int_A^B \frac{\partial V}{\partial x} dx + \frac{\partial V}{\partial y} dy + \frac{\partial V}{\partial z} dz \\ &= \int_A^B \left(\frac{\partial V}{\partial x}, \frac{\partial V}{\partial y}, \frac{\partial V}{\partial z} \right) \cdot (dx, dy, dz) \end{aligned} \quad (1.83)$$

With the standard definition of the gradient:

$$\vec{\nabla} = \left(\frac{\partial}{\partial x}, \frac{\partial}{\partial y}, \frac{\partial}{\partial z} \right) \quad (1.84)$$

we find:

$$\begin{aligned} V_B - V_A &= \int_A^B \vec{\nabla}V \cdot (dx, dy, dz) \\ &= \int_A^B \vec{\nabla}V \cdot d\vec{l} \end{aligned} \quad (1.85)$$

Combining Equations 1.82 and 1.85 leads to:

$$\vec{E} = -\vec{\nabla}V \quad (1.86)$$

Thus the gradient of V has a physical interpretation; it is the electrical field (with a minus sign). This closes the circle. We can now determine the potential from the electric field and vice versa.

For completeness we express Gauss' Law in terms of the electric potential. For that we need the Laplacian operator, $\vec{\nabla}^2$, defined by:

$$\vec{\nabla}^2 = \left(\frac{\partial^2}{\partial x^2} + \frac{\partial^2}{\partial y^2} + \frac{\partial^2}{\partial z^2} \right). \quad (1.87)$$

Now we go back to Gauss' Law and derive:

$$\begin{aligned} \vec{\nabla} \cdot \vec{E} &= \vec{\nabla} \cdot (\vec{\nabla}V) \\ &= \vec{\nabla}^2 V = \frac{\rho}{\epsilon_0} \end{aligned} \quad (1.88)$$

which is usually called 'Poisson's equation'. Let's throw in one more definition. In the absence of any charge, Poisson's equation becomes:

$$\vec{\nabla}^2 V = 0 \quad (1.89)$$

which is called Laplace's equation.

The electrical potential and field of a point charge

We determined the potential for a point charge to be:

$$V = \frac{Q}{4\pi\epsilon_0} \frac{1}{r} \quad (1.90)$$

Now we check whether the expression $\vec{E} = -\vec{\nabla}V$ returns the correct electrical field. We start with:

$$\begin{aligned} \vec{\nabla} \frac{1}{r} &= \vec{\nabla} \frac{1}{\sqrt{x^2 + y^2 + z^2}} \\ &= \frac{\partial}{\partial x} \frac{1}{\sqrt{x^2 + y^2 + z^2}} \hat{x} + \frac{\partial}{\partial y} \dots \hat{y} + \frac{\partial}{\partial z} \dots \hat{z} \\ &= -\frac{x}{(x^2 + y^2 + z^2)^{\frac{3}{2}}} \hat{x} - \frac{y}{(x^2 + y^2 + z^2)^{\frac{3}{2}}} \hat{y} - \frac{z}{(x^2 + y^2 + z^2)^{\frac{3}{2}}} \hat{z} \\ &= -\frac{1}{(x^2 + y^2 + z^2)^{\frac{3}{2}}} (x, y, z) = -\frac{\vec{r}}{r^3} = -\frac{\hat{r}}{r^2} \end{aligned} \quad (1.91)$$

and conclude that

$$\vec{\nabla}V = \frac{Q}{4\pi\epsilon_0} \vec{\nabla} \frac{1}{r} = -\frac{Q}{4\pi\epsilon_0} \frac{1}{r^2} \hat{r} = -\vec{E} \quad (1.92)$$

Most expressions in electrodynamics involve spherical symmetric function. For such a function, $f(r)$, you can quickly determine the gradient using the following relation.

$$\vec{\nabla}f(r) = \frac{df}{dr} \hat{r} \quad (1.93)$$

The potential of a charged sphere

In Section 1.3.4 we determined the electrical field inside and outside a massive spherical charge with radius R and charge density ρ .

$$\begin{aligned} \vec{E} &= \frac{\rho r}{3\epsilon_0} \hat{r} \quad r < R \\ \vec{E} &= \frac{\rho R^3}{3\epsilon_0 r^2} \hat{r} \quad r > R \end{aligned} \quad (1.94)$$

As an example we calculate the potential inside the spherical charge.

$$V(r) = -\int_{\infty}^r \vec{E} \cdot d\vec{l} = -\int_{\infty}^R \vec{E} \cdot d\vec{l} - \int_R^r \vec{E} \cdot d\vec{l} \quad (1.95)$$

We substitute the expression for the electrical field and find:

$$\begin{aligned} V(r) &= -\int_{\infty}^R \frac{\rho R^3}{3\epsilon_0 r^2} dr - \int_R^r \frac{\rho r}{3\epsilon_0} dr \\ &= \frac{\rho R^3}{3\epsilon_0 r} \Big|_{\infty}^R - \frac{\rho r^2}{6\epsilon_0} \Big|_R^r \\ &= \frac{\rho R^3}{3\epsilon_0 R} - \frac{\rho r^2}{6\epsilon_0} + \frac{\rho R^2}{6\epsilon_0} \\ &= \frac{\rho R^2}{2\epsilon_0} - \frac{\rho r^2}{6\epsilon_0} \end{aligned} \quad (1.96)$$

At this point it may be not yet clear why the potential is relevant anyway. Don't worry about that now and make sure you understand the mathematics.

The potential of a circular charge

We introduced the potential and perhaps the idea came to your mind 'where do we need that for'. Well, to calculate the electrical field of complex charge configuration can be a difficult task, even numerically³. Starting with a calculation of the potential and then calculate the electrical field is often much easier.

We want to calculate the electrical field at a distance d of a circular charge with radius R as indicated in Fig. 1.25. the charge is positioned parallel to the XY plane, centered at $z = d$ with

³there will be an exciting exercise in the second year course on 'Numerical Physics'

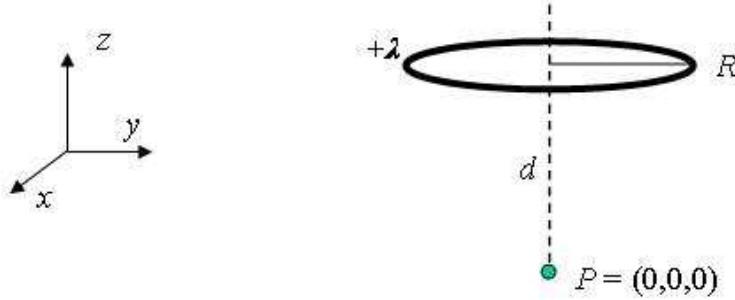

Figure 1.25: A circular charge positioned parallel to the XY plane, centered at $z = d$ with radius R carries a uniform charge density λ . Point P , that coincides with the origin is also indicated.

uniform charge density λ . To calculate the field at distance d , which is the origin in our case, we first calculate the electrical potential using equation 1.79:

$$V_P = \int_{\text{circular-charge}} \frac{dq}{4\pi\epsilon_0 r} \quad (1.97)$$

with $r = \sqrt{R^2 + d^2}$ the distance to a piece of charge $dq = \lambda R d\phi$. Rather straightforward we obtain:

$$V_P = \int_0^{2\pi} \frac{\lambda}{4\pi\epsilon_0} \frac{R}{\sqrt{R^2 + d^2}} d\phi = \frac{\lambda}{2\epsilon_0} \frac{R}{\sqrt{R^2 + d^2}} \quad (1.98)$$

When we define the total charge $Q = 2\pi R\lambda$, the above expression becomes:

$$V_P = \frac{Q}{4\pi\epsilon_0} \frac{1}{\sqrt{R^2 + d^2}} \quad (1.99)$$

We can now obtain the electrical field from the potential using $E = -\vec{\nabla}V$. The general expression for V somewhere along the z axis is:

$$V(z) = \frac{Q}{4\pi\epsilon_0} \frac{1}{\sqrt{R^2 + (z-d)^2}} \quad (1.100)$$

For the electrical field follows:

$$\begin{aligned} \vec{E} &= -\frac{\partial V}{\partial x} \hat{x} - \frac{\partial V}{\partial y} \hat{y} - \frac{\partial V}{\partial z} \hat{z} \\ &= 0\hat{x} - 0\hat{y} - \frac{Q}{4\pi\epsilon_0} \frac{\partial}{\partial z} \frac{1}{\sqrt{R^2 + (z-d)^2}} \hat{z} \\ &= \frac{Q}{4\pi\epsilon_0} \frac{(z-d)}{(R^2 + (z-d)^2)^{3/2}} \hat{z} \end{aligned} \quad (1.101)$$

Of course, this result can also be obtained from direct integration, but that requires a somewhat more complicated integration. Just do it and check the result!

The electrical field of a dipole

Another example where the electrical potential makes life easier is the calculation of the field of an electrical dipole. Figure 1.26 shows a electrical dipole configuration, consisting of two opposite point charges at a distance $2d$. The potential in a point $P(r, \theta)$ has a contribution from the positive

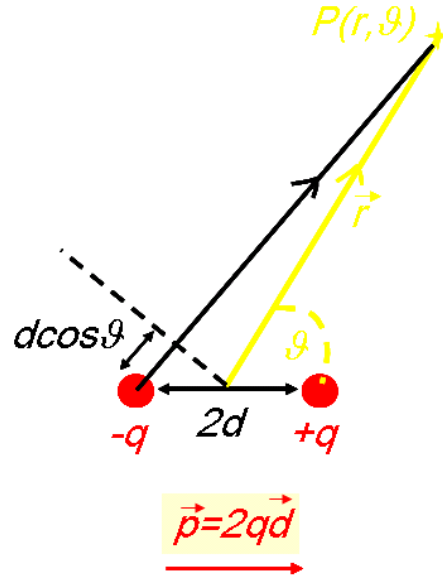

Figure 1.26: An electrical dipole consisting of two opposite point charges at distance $2d$.

and negative point charge. Thus,

$$V_P(r, \theta) = V_+ + V_- = \frac{q}{4\pi\epsilon_0 r_+} + \frac{-q}{4\pi\epsilon_0 r_-} \quad (1.102)$$

with r_{\pm} the distance between the corresponding point charge and point P . When $r \gg d$ we can make the approximation:

$$r_{\pm} = r \mp d \cos(\theta) \quad (1.103)$$

Verify this yourself. For the potential in P we obtain:

$$V_P(r, \theta) = \frac{q}{4\pi\epsilon_0} \left(\frac{1}{r - d \cos(\theta)} - \frac{1}{r + d \cos(\theta)} \right) \quad (1.104)$$

We can simplify this expression, using a 'cunning' trick. Multiply the nominators and denominators with $r + d \cos(\theta)$ and $r - d \cos(\theta)$ respectively and realize that $(r + d \cos(\theta))(r - d \cos(\theta)) = r^2 - d^2 \cos^2(\theta)$. Remember that we work in approximation $r \gg d$ and thus $r^2 - d^2 \cos^2(\theta) \simeq r^2$. The leads to

$$\begin{aligned} V_P(r, \theta) &= \frac{q}{4\pi\epsilon_0} \frac{2d \cos(\theta)}{r^2} \\ &= \frac{2qd \cos(\theta)}{4\pi\epsilon_0 r^2} \\ &\equiv \frac{p \cos(\theta)}{4\pi\epsilon_0 r^2} = \frac{\vec{p} \cdot \hat{r}}{4\pi\epsilon_0 r^2} = \frac{\vec{p} \cdot \vec{r}}{4\pi\epsilon_0 r^3} \end{aligned} \quad (1.105)$$

where $\vec{p} = 2q\vec{d}$. The quantity \vec{p} is called the dipole moment. Mathematical dipoles have distance $d \rightarrow 0$ and $q \rightarrow \infty$, such that $p = 2qd$ remains constant.

Now we determine the electrical field by taking the gradient of the potential:

$$\begin{aligned}\vec{E}_P &= -\vec{\nabla}V_P = -\vec{\nabla}\left(\frac{\vec{p}\cdot\vec{r}}{4\pi\epsilon_0 r^3}\right) \\ &= -\frac{1}{4\pi\epsilon_0}\left(\frac{\partial}{\partial x}\frac{xp_x+yp_y+zp_z}{r^3}, \dots, \dots\right) \\ &= -\frac{1}{4\pi\epsilon_0}\left(\frac{p_x}{r^3} - \frac{3x(xp_x+yp_y+zp_z)}{r^5}, \dots, \dots\right) \\ &= \frac{1}{4\pi\epsilon_0}\frac{-\vec{p}+3\hat{r}(\hat{r}\cdot\vec{p})}{r^3}\end{aligned}\tag{1.106}$$

The drop of the magnitude of the field with r^3 is characteristic for a dipole field.

The potential of a line charge

Several examples convinced us starting with the electrical potential simplifies the calculation of the electrical field. The following example shows that we have to be careful.

We calculate the electric potential of an infinitely long line charge in point P by integrating over all charge on the line (see Equation 1.79):

$$V_P = \int_{line} \frac{dq}{4\pi\epsilon_0 r}\tag{1.107}$$

We put the line on the z -axis and thus $dq = \lambda dz$. Hence,

$$V_P = \int_{-\infty}^{+\infty} \frac{\lambda}{4\pi\epsilon_0 \sqrt{r_P^2 + z^2}} dz\tag{1.108}$$

$$= \frac{\lambda}{4\pi\epsilon_0} \ln(z + \sqrt{1+z^2}) \Big|_{-\infty}^{+\infty} = \text{undefined!}\tag{1.109}$$

How can this be? Well, remember our definition of the potential in equation 1.81 and also look at equation 1.78. We have taken the gauge-point of the potential at infinity, which has been a reasonable choice for charge configurations with a potential vanishing at infinity. However, the potential of the infinitely long line charge doesn't.

In this case we have to obtain the potential by integration of the electrical field. In Section 1.3.4 we calculated the electrical field at radial distance r of an infinitely long line charge:

$$\vec{E}(\vec{r}) = \frac{\lambda}{2\pi\epsilon_0 r} \hat{r}\tag{1.110}$$

and thus

$$V_P = -\int_{gauge}^P \vec{E} \cdot d\vec{r} = -\frac{\lambda}{2\pi\epsilon_0} \ln(r) \Big|_{gauge}^P\tag{1.111}$$

When we choose gauge-point $r = 1$ we obtain:

$$V_P = -\frac{\lambda}{2\pi\epsilon_0} \ln(r)\tag{1.112}$$

But isn't it bizarre that we can just choose a gauge? Perhaps it is, but remember that the potential is not a physical quantity. The electrical field is a physical quantity and also the potential difference in two points, which is even easily measurable, and these quantities remain independent of the gauge-point.

1.5.5 The energy of a charge configuration

We have already discussed that the work needed to bring one point charge, q from infinity to a point P in the field of another point charge equals:

$$U = W = - \int_{\infty}^P q \vec{E} \cdot d\vec{l} = \int_{\infty}^P q \vec{\nabla} V \cdot d\vec{l} = qV_P \quad (1.113)$$

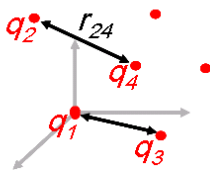

Figure 1.27: Illustration of a collection of point charges.

Figure 1.27 shows a collection of point charges. To determine the energy of a charge collection (of point charges) we have to calculate how much work is required to assemble such collection. The first charge takes no force (there is no field yet) and thus physically no work is done. To place the second charge, we require $W_2 = q_2 V(r_{12}) = \frac{q_2}{4\pi\epsilon_0} \frac{q_1}{r_{12}}$, where r_{12} represents the distance between charge q_1 and q_2 . When we bring in the third charge we feel the field of the first and second charge, thus:

$$W_3 = q_3 V(r_{13}) + q_3 V(r_{23}) = q_3 \left(\frac{q_1}{4\pi\epsilon_0 r_{13}} + \frac{q_2}{4\pi\epsilon_0 r_{23}} \right) \quad (1.114)$$

The total energy of our collection so-far is

$$W_{123} = W_1 + W_2 + W_3 = 0 + \frac{q_1 q_2}{4\pi\epsilon_0 r_{12}} + \frac{q_1 q_3}{4\pi\epsilon_0 r_{13}} + \frac{q_2 q_3}{4\pi\epsilon_0 r_{23}} \quad (1.115)$$

For a collection of N point charges we find:

$$W_N = \frac{1}{2} \sum_{i=1}^N \sum_{j \neq i}^N \frac{q_i q_j}{4\pi\epsilon_0 r_{ij}} = \frac{1}{2} \sum_{i=1}^N q_i V(r_i) \quad (1.116)$$

Note that all combinations of q_i and q_j appear twice, which is accounted for by the factor $\frac{1}{2}$. Another remark we have to make is that the self-energy to make the point charges is completely ignored in the above expressions.

1.5.6 The energy of continuous charge distribution

For a volume charge density we can generalize Equation 1.116 and obtain:

$$W = \frac{1}{2} \int_{\text{volume}} \rho V dv \quad (1.117)$$

Consider the following question of a smart student. There appears a contribution from the charge ρdv , sensing its own potential in infinitesimal volume dv . Such contribution from the self energy is not present in equation 1.116. Wouldn't this contribution lead to unphysical results? To check the size of this contribution, we imagine that our continuous charge distribution consists of infinitesimal charged spheres. We calculate the self energy of a uniformly charged sphere with (infinitesimal) radius R , due to its own potential (see equation 1.96):

$$\begin{aligned} W_{\text{self}} &= \frac{1}{2} \int_{\text{sphere}} \rho V_{\text{inside}} dv = \frac{1}{2} \int_0^R \rho \left(\frac{\rho R^2}{2\epsilon_0} - \frac{\rho r^2}{6\epsilon_0} \right) 4\pi r^2 dr \\ &= \frac{1}{2} \int_0^R \left(\frac{4\pi\rho^2 R^2 r^2}{2\epsilon_0} - \frac{4\pi\rho^2 r^4}{6\epsilon_0} \right) dr \\ &= \frac{1}{2} \left(\frac{4\pi\rho^2 R^5}{6\epsilon_0} - \frac{4\pi\rho^2 R^5}{30\epsilon_0} \right) \\ &= \frac{4\pi\rho^2 R^5}{15\epsilon_0} \end{aligned} \quad (1.118)$$

Remember that our sphere is infinitesimal ($R \rightarrow 0$) and thus the contribution $W_{\text{self}} = 0$. Hence, equation 1.117 correctly represents the energy of a continuous charge distribution.

1.5.7 The energy in the electrical field

Starting point is the energy of the continuous charge distribution.

$$W = \frac{1}{2} \int_{\text{volume}} \rho V dv \quad (1.119)$$

Substitute Gauss's law $\vec{\nabla} \cdot \vec{E} = \rho/\epsilon_0$:

$$W = \frac{\epsilon_0}{2} \int_{\text{volume}} (\vec{\nabla} \cdot \vec{E}) V dv \quad (1.120)$$

We can further simplify this expression. Therefore we first consider the expression:

$$\begin{aligned} \vec{\nabla} \cdot (\vec{E}V) &= \frac{\partial(E_x V)}{\partial x} + \dots \\ &= \left(\frac{\partial E_x}{\partial x} \right) V + \left(\frac{\partial V}{\partial x} \right) E_x + \dots \\ &= (\vec{\nabla} \cdot \vec{E}) V + \vec{E} \cdot (\vec{\nabla} V) \end{aligned} \quad (1.121)$$

We return to the energy (equation 1.120) and use equation 1.121 to write:

$$\begin{aligned} W &= \frac{\epsilon_0}{2} \int_{\text{volume}} \left(\vec{\nabla} \cdot (\vec{E}V) - \vec{E} \cdot (\vec{\nabla} V) \right) dv \\ &= \frac{\epsilon_0}{2} \int_{\text{volume}} \left(\vec{\nabla} \cdot (\vec{E}V) + \vec{E} \cdot \vec{E} \right) dv \\ &= \frac{\epsilon_0}{2} \int_{\text{volume}} \left(\vec{\nabla} \cdot (\vec{E}V) \right) dv + \frac{\epsilon_0}{2} \int_{\text{volume}} \left(\vec{E}^2 \right) dv \end{aligned} \quad (1.122)$$

Using Gauss' Theorem 1.58, we obtain:

$$W = \frac{\epsilon_0}{2} \int_{surface} (\vec{E}V) d\vec{o} + \frac{\epsilon_0}{2} \int_{volume} \vec{E}^2 dv \quad (1.123)$$

The integral of the surface equals zero. Why? Suppose we consider the field of a point charge. The electrical field drops with $1/r^2$ and the potential with $1/r$. We can write:

$$\int_{surface} d\vec{o} \cdot \vec{E}V \approx \int_{surface} d\vec{o} \cdot 1/r^3 \approx \int_{surface} d\phi d\theta \sin(\theta) 1/r \quad (1.124)$$

We should consider a surface enclosing all space, thus $r \rightarrow \infty$ and thus

$$\int_{surface} d\phi d\theta \sin(\theta) 1/r = 0 \quad (1.125)$$

Finally, we obtain for the energy of the electrical field:

$$W = \frac{\epsilon_0}{2} \int_{volume} \vec{E}^2 dv \quad (1.126)$$

\vec{E} , V and Energy of a spherical surface charge

In Section 1.3.4 we calculated the electrical field of a charged spherical surface (or shell) with radius R and charge density σ . We found that outside the shell:

$$\vec{E} = E_r \hat{r} = \frac{\sigma R^2}{\epsilon_0 r^2} \hat{r} \quad r > R \quad (1.127)$$

Inside the the sphere no charged is enclosed and thus $E_r = 0$.

What is the potential as function of r ? We use $V(r) = -\int_{\infty}^r \vec{E} \cdot d\vec{l}$ and write:

$$V(r) = -\int_{\infty}^r dr \frac{\sigma R^2}{\epsilon_0 r^2} = \frac{\sigma R^2}{\epsilon_0 r} \quad r > R \quad (1.128)$$

Now, calculate the potential inside the sphere (where the electrical field is zero):

$$V(r) = -\int_{\infty}^R \vec{E} \cdot d\vec{l} - \int_R^r \vec{E} \cdot d\vec{l} = V(R) + 0 = \frac{\sigma R}{\epsilon_0} \quad r < R \quad (1.129)$$

You could always check the results for the potential by calculating the electrical field using $\vec{E} = -\vec{\nabla}V$. The results for the electrical field are also shown in Fig 1.28, where you can see that inside the surface the electrical field becomes zero, while the potential is constant, $V(R)$.

Now we can calculate the energy of this configuration in two ways. We start with the expression for the energy based on the potential (equation 1.117). The volume charge density ρ is zero everywhere, except on the spherical surface where it is σ . Hence,

$$W = \frac{1}{2} \int_{volume} \rho V dv \rightarrow \frac{1}{2} \int_{surface} \sigma V(R) do \quad (1.130)$$

$$= \frac{1}{2} \int_{surface} \sigma \frac{\sigma R}{\epsilon_0} do = \frac{1}{2} 4\pi R^2 \sigma \frac{\sigma R}{\epsilon_0} = 2\pi \frac{\sigma^2 R^3}{\epsilon_0} \quad (1.131)$$

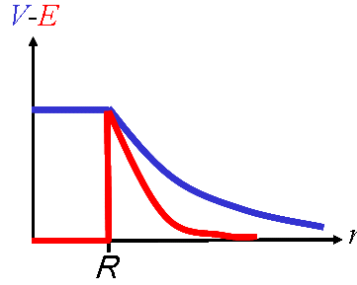

Figure 1.28: The electrical field and the potential of a spherical surface charge

The other expression for the energy with the electrical field in quadrature (equation 1.126) should yield the same result. Let's check that.

$$\begin{aligned}
 W &= \frac{\epsilon_0}{2} \int_{\text{volume}} \vec{E}^2 dv = \frac{\epsilon_0}{2} \int_{r>R} \vec{E}^2 dv \\
 &= \frac{\epsilon_0}{2} \int_{r>R} \left(\frac{R^2 \sigma}{r^2 \epsilon_0} \right)^2 dv = \frac{4\pi \epsilon_0}{2} \int_{r>R} dr \left(\frac{R^2 \sigma}{\epsilon_0} \right)^2 \frac{1}{r^2} \\
 &= \frac{4\pi \epsilon_0}{2} \left(\frac{R^2 \sigma}{\epsilon_0} \right)^2 \frac{1}{r} \Big|_R^\infty = 2\pi \frac{\sigma^2 R^3}{\epsilon_0}
 \end{aligned} \tag{1.132}$$

as expected.

1.5.8 Knowledge and Skills

The knowledge and skills you should have acquired during reading of the previous can be summarized as follows:

- You understand the definition (and the derivation) of the potential:

$$V_P = - \int_{\text{gauge}}^P \vec{E} \cdot d\vec{l} \tag{1.133}$$

For a point charge, the potential is given by:

$$V_P = \frac{U_P}{q} = \frac{Q}{4\pi \epsilon_0 r_P} \tag{1.134}$$

- you can also calculate the electrical field given the potential, using $\vec{E} = -\vec{\nabla}V$.
- you understand how we derived the energy of a charge collection:

$$W_N = \frac{1}{2} \sum_{i=1}^N \sum_{j \neq i}^N \frac{q_i q_j}{4\pi \epsilon_0 r_{ij}} = \frac{1}{2} \sum_{i=1}^N q_i V(r_i) \tag{1.135}$$

- For a continuous charge density the energy is given by:

$$W = \frac{1}{2} \int_{\text{volume}} \rho V dv \tag{1.136}$$

or, alternatively:

$$W = \frac{\epsilon_0}{2} \int_{\text{volume}} \vec{E}^2 dv \quad (1.137)$$

which you can apply for a spherical charge density.

In addition, make the corresponding exercises of this section, which you can find in the Appendix.

1.6 Electrical fields in matter

So-far, we considered electrical fields in vacuum. Usually we started with some (symmetrical) charge configuration and then we calculated the electrical field, its potential or energy. What if we place (electrically neutral) objects in the electrical field? What happens inside those objects and what is the effect on the electrical field in and outside the object? In this Section we will discuss these questions and more.

1.6.1 The Conductor

What is a conductor? For our purposes a conductor is an object that conducts electrical currents because the negative charge carriers (electrons) can move freely inside the material. The number of the free charge carriers is unlimited. Materials that approach these ideal properties are metals like iron, copper and gold. If the conductor is electrically neutral, it contains an equal amount of negative and positive charge. The positive charge is always bound and thus cannot move freely through the material.

Given the above we can deduce what happens when a conductor is placed inside an electrical field as illustrated in Fig. 1.29.

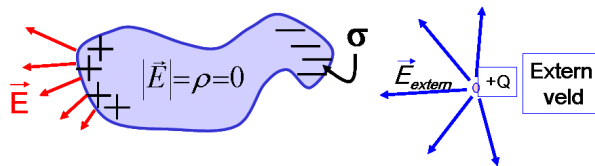

Figure 1.29: A conductor is placed in an extern electrical field.

- What is the electrical field inside a conductor? Suppose there is an electrical field in the conductor. Then, the free electrons would be subjected to the electrical force and start moving. Well, they may do for a short time when the field is just turned on, but we discuss only electrostatic situations. There is only one stable solution to our question and that is that there is no electrical field inside a conductor!
- How can the field be zero inside a conductor? Well, suppose the electrical field is just turned on. Then some free electrons will be attracted by the electrical force and flow to the surface of the conductor (they can not escape). This process goes on till the electrical field inside the conductor has vanished, or better, the original field gets canceled by the field of the free charge sitting on the surface and the nett positive charge that keeps its original position⁴. In

⁴This is always possible in one, and only one, way based on the 'uniqueness theorem'. The derivation of this theorem is beyond the scope of this course.

general, the nett positive charge will appear on the opposite surface with respect to the side of the free negative charge.

- What is the charge density inside the conductor? We know now that the field inside the conductor is zero. Hence, $\vec{\nabla} \cdot \vec{E} = \rho/\epsilon_0 = 0$. The charge density ρ inside the conductor must be zero. Thus, any nett negative or positive charge must sit on the surface(s) of the conductor.
- What about the electrical field on the surface? Suppose there is an electrical field along the surface of the conductor. The free charge carriers will immediately 'respond' and flow into a configuration with no electrical charge along the surface. Hence, there are no electrical field components along the surface of a conductor. Now suppose there is electrical field perpendicular to the surface. The charge sitting just on the surface will be attracted or repelled by the field, but it cannot move inward or outward the conductor. This is a stable situation and thus there can be an electrical field just outside an conductor perpendicular to its surface.
- Is there a potential in a conductor? No, there can't be, because $V(a) - V(b) = -\int_a^b \vec{E} \cdot d\vec{l} = 0$. At any place inside or at the surface of a conductor the potential is constant.

#	characteristic	why
1	$\vec{E} = 0$ inside a conductor	otherwise charge starts moving.
2	$\rho = 0$ inside a conductor	$\vec{\nabla} \cdot \vec{E} = 0 = \rho/\epsilon_0$.
3	charge sits on the surface	where-else could it be?
4	V is constant inside a conductor	$V(a) - V(b) = -\int_a^b \vec{E} \cdot d\vec{l} = 0$.
5	Field lines leave the conductor perpendicular.	otherwise the surface-charge starts moving.

Table 1.1: *The conductor rules.*

Table 1.1 summarizes the electric characteristics of the conductor. So, we know now what happens if we place a conductor inside an electrical field. Well, not really. The (original) field outside the conductor also changes and we have not discussed that. This is a tough problem to solve without a general solution. When there is an obvious symmetry in the configuration we can give the solution. It will take a lot of practice to adopt a 'feeling' for these configurations. Anyway, the examples in the following paragraph help you to get started.

A conducting plate in a uniform electrical field.

We start with a given uniform electrical field $E_{external}$ in the horizontal (z) direction and then place an infinitely large conducting plate as shown in Fig. 1.30a. After a few nanoseconds an electrostatic configuration exists. What is the resulting electrical field?

Start by applying the rules of conductors (Table 1.1) to get the nett charge configuration. Then, with the charge configuration we can calculate the electrical field everywhere using standard techniques as we have been doing in the previous Sections.

So, we know that the nett charge will sit on the surface (rule 2 and 3). We can replace the plate by the electrical configuration as shown in Fig. 1.30b. This situation is physically equivalent. Of course we also need to know the amount of charge, or better, the charge density σ_- and σ_+ . We started with a neutral plate, so for sure $\sigma = \sigma_+ = -\sigma_-$. According to rule 1, the field inside the



Figure 1.30: a) An infinitely large conducting plate is placed in an external electrical field in the z direction. b) The physical equivalent charge configuration on the plate.

conductor shall be zero. Hence, in the region where the plate resided, the electrical fields from the charge densities have to cancel the external field:

$$\vec{E}_{in-plate} = \vec{0} = \vec{E}_{external} + \vec{E}_{(-)} + \vec{E}_{(+)} \quad (1.138)$$

We have already calculated the electrical field of a flat surface charge: $E_{\pm} = \frac{\sigma_{\pm}}{2\epsilon_0}$, which we substitute in the above expression:

$$\vec{0} = \vec{E}_{external}\hat{z} + \frac{-\sigma}{2\epsilon_0}\hat{z} - \frac{\sigma}{2\epsilon_0}\hat{z} \quad (1.139)$$

from which follows:

$$\sigma = \epsilon_0 |\vec{E}_{external}| \quad (1.140)$$

Note that the (vector) contribution of the positive charge has acquired a minus sign, because it points in the negative z direction, which is also illustrated in Fig. 1.31 (for the sake of the argument we made the external field vector fit just inside the plate). Inspect the figure yourself and verify that the field inside the plate gets canceled. Outside the plate the contributions of the positive and negative charge density cancel and hence the field outside still equals $E_{external}$!

Finally, we remark that inducing two layers of opposite charge on a plate requires work. The work is performed in the small timespan before reaching the equilibrium. The external field gets the 'energy bill'. From equation 1.126 we can see that the energy difference comes from the volume inside the plate where the original field has vanished. Thus, for a plate that has a height h and thickness d , the energy difference is:

$$U = \frac{\epsilon_0}{2} \int_{volume-plate} \vec{E}_{external}^2 dv = \frac{\epsilon_0 h d}{2} \vec{E}_{external}^2 \quad (1.141)$$

(of course we demand $h \gg d$ such that we can ignore edge effects.) You can verify yourself that this equals the work needed to separate the positive and negative surface charge.

A grounded conducting plate

We can also consider a grounded plate. This means that the plate is connected to the earth. For this purpose the earth should be seen as an unlimited source of charges. Thus the earth can pump

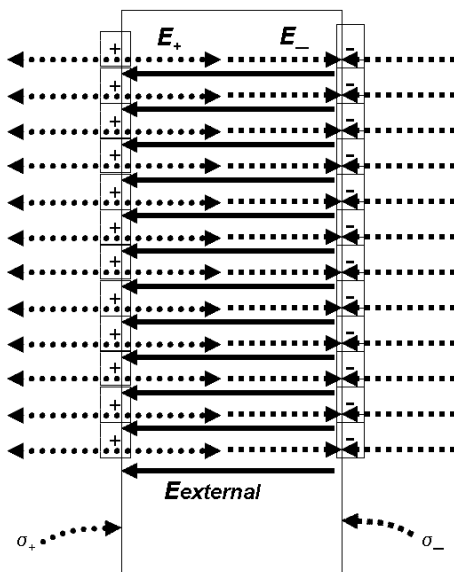

Figure 1.31: The electrical field contributions inside the plate form the external field and charge densities σ_+ and σ_- respectively.

electrons in or out the plate at no cost without acquiring any net charge itself. Furthermore, the potential of the earth is usually defined to be zero and grounded objects are at the same potential.

Figure 1.32 shows a grounded plate (as you can see from the piece of wire that ends in the special symbol for ground), together with its charge distribution.

The surface charge $\sigma_{grounded}$, needed to cancel the electrical field inside the plate, can be easily calculated using similar steps as above:

$$\sigma_{grounded} = -2\epsilon_0 |\vec{E}_{external}| \quad (1.142)$$

But why reaches the plate an equilibrium without any positive net (surface)charge as in the previous example. Well, as mentioned above, to make a positive and negative layers of charge work is performed, which requires a force. In the 'grounded' case all the necessary electrons are provided for free by the earth. Note that the field outside the plate has drastically changed. In fact, the field becomes zero everywhere left from the negative surface charge and it doubles on the right side. This also affects the energy in the field dramatically. Of course, the earth is not really an unlimited source of electrons and we have to know all the details to calculate the complete energy balance. Hence, in practice this cannot be done. In the scope of this course, our 'responsibility' ends with checking that all rules for conductors are satisfied. Check that yourself.

A spherical conducting shell with a point charge inside

We consider an electrically neutral conducting shell with an inner and outer radius of R_i and R_o respectively. We have put a positive point charge q in its center as shown in Fig. 1.33. What is the charge density in the shell and what is the electrical field everywhere in space?

It is amazing that we can answer this question given such little information for such a complicated configuration. But we can, again just by using the rules for conductor (and all the stuff we learned before). Rule nr. 1 tells us that in the meat of the shell (that is between R_i and R_o) the

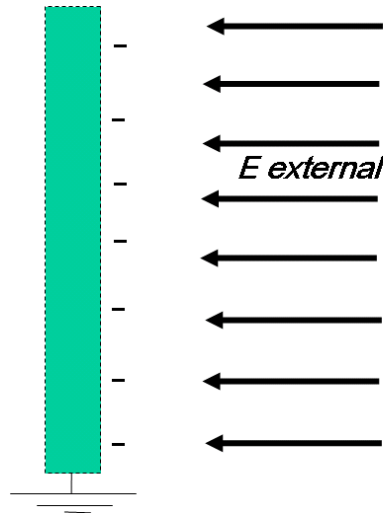

Figure 1.32: A grounded conducting plate is placed in an external electrical field. Note the international symbol for 'grounding' indicated in the figure.

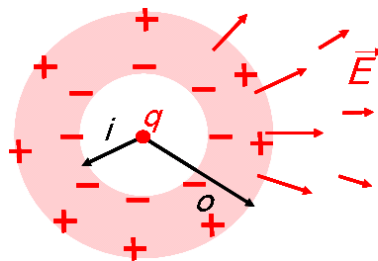

Figure 1.33: A positive point charge is positioned in a conducting shell with inner radius R_i and outer radius R_o .

electrical field of the point charge should cancel. This can (only) be achieved by induced charge on the inner and outer surface. since we started with an electrically neutral object, there must be a similar amount of induced negative and positive surface charge, $\sigma_i = -\sigma_o$ on the inner and outer surface respectively.

The question is now how to calculate the $\sigma_i = \frac{Q_i}{4\pi R_i^2}$ (or equivalently σ_o). Well, we have calculated the electrical field of a spherical surface charge density before (see equation 1.46):

$$\vec{E} = \frac{\sigma R^2}{\epsilon_0 r^2} \hat{r} \quad r > R \quad (1.143)$$

$$= \frac{Q}{4\pi \epsilon_0 r^2} \hat{r} \quad r > R \quad (1.144)$$

and $\vec{E} = 0$ inside the shell (between R_i and R_o). In the shell, we add the contributions of the point charge, the negative charge density on the inner shell and the positive one on the outer shell, we find inside the conductor:

$$\vec{0} = \vec{E}_q + \vec{E}_{Q_i} + \vec{E}_{Q_o}$$

$$= \frac{1}{4\pi\epsilon_0} \left(\frac{q}{r^2} + \frac{Q_i}{r^2} + 0 \right) \hat{r} \quad (1.145)$$

We conclude that $Q_i = -q$ (and $Q_o = -Q_i = q$). Note that the charge densities on the inner and outer surface, besides the sign, are also in magnitude not the same: $\sigma_i = -q/(4\pi R_i^2)$ and $\sigma_o = q/(4\pi R_o^2)$. Check yourself that all rules for conductors are fulfilled.

What are the consequences for the electrical field everywhere in space outside the conductor? Well, the field is just the field of the point charge. We could say that the presence of the conductor has not disturbed the outer field at all!

Finally we remark that we have been able to calculate the induced charge relatively easily because of the large symmetry in this problem. Most notably is that all contributions to the field, i.e.: that of the point charge, the surface charge at R_i and the charge at R_o all have radially pointing contributions. For a weird shaped conductor in an external field you can try, just for fun, to make a sketch of the charge distribution on its surface.

Method of images

A powerful technique to calculate the electrical field in many situations is the 'method of images' using a 'mirror charge'. This method relies on the fact (not derived here) that the electric potential is uniquely defined *inside* some volume

with a given charge density inside the volume, and,

with given the potential at its boundary surface.

In such case we may change the original charge configuration outside the volume by an alternative configuration respecting the boundary conditions. Inside the volume the electrical potential of the alternative configuration equals that of the original configuration. You may have to read the previous sentence twice. Outside this volume, the potential of the original and alternative configuration generally completely differ. In the following example we will see the strength of this method.

We consider a grounded plate and place a point charge q at a distance d as illustrated in Fig. 1.34. The point charge induces charge on the plate surface with an a priori unknown distribution. For this example the plate is infinitely large and infinitely thin. What is the electrical field everywhere? Well, on the right side of the plate ($z > 0$) we have a volume with a given charge density (the point charge) and we know the potential at the boundaries: $V = 0$ at the plate ($z = 0$) and at infinity.

Hence, it is allowed to use the technique of the mirror charge. We have to keep the point charge, but can remove the plate if we can find a charge configuration that gives the same potential $V = 0$ at the boundary $z = 0$ and $z = +\infty$. As the name of the technique suggests, put a mirror charge ($-q$) at $z = -d$ which leads to the configuration shown in Fig. 1.35. Are the boundary conditions fulfilled? At $z = 0$ the contributions to the electric potential of the two charges cancel and at infinity (by the way: only positive z is relevant in this case) the potential is also still zero. The resulting configuration is an electrical dipole which we have seen before. Hence, we know the potential for $z > 0$ now. But what about the potential in the region $z < 0$. This is outside our volume with known boundary conditions. It is certainly wrong to use the potential for a dipole in this region!

The trick is to go back to the original configuration and first determine the charge density on the plate. For $z > 0$ we know the potential is given by:

$$V(x, y, z) = \frac{1}{4\pi\epsilon_0} \left(\frac{q}{\sqrt{x^2 + y^2 + (z-d)^2}} - \frac{q}{\sqrt{x^2 + y^2 + (z+d)^2}} \right) \quad (1.146)$$

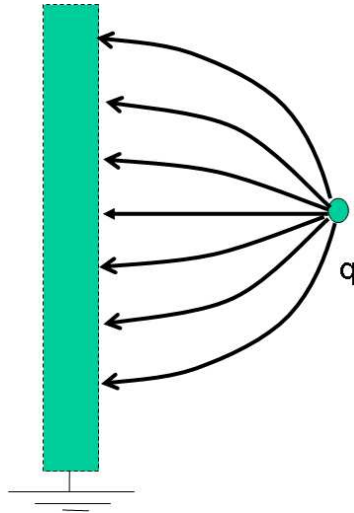

Figure 1.34: A grounded conducting plate is placed in the field of a point charge q . The point charge is positioned at $z = d$ and the right surface of the plate is located at $z = 0$.

The corresponding electrical field can be calculated using $\vec{E}(x, y, z) = -\vec{\nabla}V(x, y, z)$. For the field at $z = 0$ we find:

$$\vec{E}(x, y, 0) = \frac{Q}{4\pi\epsilon_0} \left(\frac{2d}{(x^2 + y^2 + (d)^2)^{\frac{3}{2}}} \right) \hat{z} \quad (1.147)$$

as you can check yourself. Now we know the electrical field (for $z > 0$) which allows us to determine the charge density on the plate using the relation $\frac{\sigma}{2\epsilon_0} = \vec{E}(z = 0) \cdot \hat{z}$ (see equation 1.42). Hence,

$$\sigma(x, y) = \frac{q}{4\pi} \left(\frac{d}{(x^2 + y^2)^{\frac{3}{2}}} \right), \quad (1.148)$$

which together with the the point charge at $z = d$ determines the physical situation, enabling us to calculate the field everywhere.

We have discussed when and how you can use the method of images and we will conclude this section by summarizing this method:

- Check the following. the potential should be known at the boundaries. Inside the boundaries, the charge density should be known as well.
- Find an alternative charge configuration outside the boundaries that respects (together with the charge density inside) the original boundary conditions.
- Calculate the potential of the alternative configuration.
- If required, you can calculate the original charge configuration using the potential (or electric field).

There is no general concept that returns the alternative configuration and it probably became clear to you that it needs some experience to find such configuration.

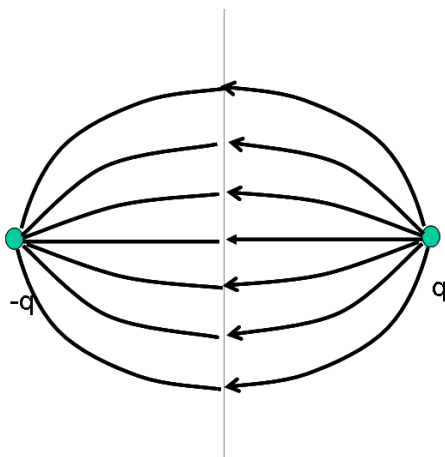

Figure 1.35: *An alternative charge configuration, existing of a electrical dipole.*

1.6.2 Capacitors

We take two parallel plates of conducting material and charge the plates with opposite charge as indicated in Fig. 1.36. The plates are separated by a distance d . We ignore the thickness of the plates and assume that the plates have a large surface A with respect to d . We have calculated the

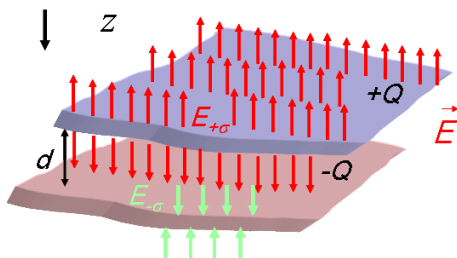

Figure 1.36: *Two parallel plates of conducting material. The plate have opposite charge Q and are separated by a distance d . The contribution to the electrical field of each plate individual is also indicated.*

electrical field for an infinitely large flat surface charge already in Sec. 1.3.4, which provides a good approximation for the present configuration with $A \gg d$. We have to add the contribution of the two plates. In between the plates, we obtain:

$$\vec{E} = \frac{+Q}{2A\epsilon_0}\hat{z} - \frac{-Q}{2A\epsilon_0}\hat{z} = \frac{Q}{A\epsilon_0}\hat{z} \quad (1.149)$$

The electrical field is constant and points away from the positive charged plate. The contribution of the negative charge obtain an additional minus sign, because if it would be a positive charge the field would point in the negative z direction. Make sure you understand this argument.

The potential difference between the plates is given by:

$$V = V_+ - V_- = - \int_-^+ \vec{E} \cdot dz = - \frac{1}{A\epsilon_0} Q \int_d^0 dz = \frac{d}{A\epsilon_0} Q \quad (1.150)$$

What we have shown now is that the potential difference between the conductors is proportional to Q , which is generally valid for capacitors.

Is the behavior $V \sim Q$ independent on the shape and size of the conductors? Yes. Suppose you take two conductors of arbitrary shape and size as illustrated in Fig. 1.37. The electrical field is

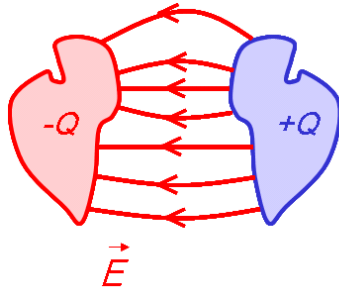

Figure 1.37: A capacitor, consisting of two conductors with bizarre shapes.

proportional to the charge density in, or better *on*, the conductors. The charge density is proportional to Q . The potential V is proportional to E and thus also to Q .

Capacitance

We have seen that $V \sim Q$. Now we introduce a constant of proportionality called capacitance, C , such that

$$C = \frac{Q}{V} \quad (1.151)$$

The capacitance depends completely on the geometry of the electrical configuration. For the configuration with the two plates, we have shown that $C = \frac{A\epsilon_0}{d}$. The larger A and the smaller d the more charge can be stored in the configuration for the same potential V . The unity of capacitance is called Farad (=Coulomb/Volt), denoted by F. In practice C , measured in Farad is numerically small. For our plate configuration with $d = 1$ mm and $A = 1$ m, $C = 9 \times 10^{-11}$ F. In the newspapers a few years ago, there was an item about a small capacitor with $C = 1$ F, but I haven't figured out yet how to make that. Let me know if you find the 'trick' on the web.

The energy of a capacitor

We start with an uncharged capacitor and move electrons from one conductor to the other to charge it up. The electrons 'sense' the electrical force in this process. Hence, moving them requires energy.

The energy needed to bring some charge dq to the other conductor is $dU = V(q)dq$. With $V(q)$ the potential difference between the two conductors as function of the already moved charge q . Since the capacitance C is a purely geometrical quantity we can write $V(q) = q/C$ and thus $dU = \frac{q dq}{C}$. The total energy of a charge capacitor is then given by:

$$U = \int dU = \int_0^Q \frac{q dq}{C} = \frac{1}{2} \frac{q^2}{C} \Big|_0^Q = \frac{1}{2} \frac{Q^2}{C} = \frac{1}{2} CV^2 \quad (1.152)$$

with Q and V the final charge and potential of the capacitor respectively.

Examples of Capacitors

Cylindrical configuration

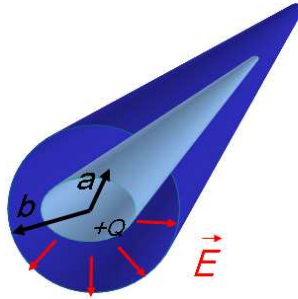

Figure 1.38: Two coaxial conductors. The inner and outer conductors have radii a and b respectively. The conductors have opposite total charge Q .

Figure 1.38 shows a cylindrical configuration, consisting of two coaxial conductors with length L . The inner conductor has a radius a . The outer radius is b and is much smaller than the length. The conductors have opposite total charge Q . What is the capacitance of this configuration?

- First, determine the electrical field in the space between the two conductors. We may assume that $L \gg b$ which implies that away from the edges the field is radial. The charge density on the inner conductor is $\sigma_i = \frac{Q}{2\pi aL}$. We calculate the flux through an imaginary small cylindrical Gaussian surface and obtain:

$$E_r 2\pi r l = \frac{\sigma_i 2\pi a l}{\epsilon_0} \quad (1.153)$$

Note that in between the conductors there is no contribution to the flux (and field) from the outer conductor. The electrical field is $\vec{E} = \frac{\sigma_i a}{\epsilon_0 r} \hat{r}$

- The potential difference between the two conductors is given by:

$$V = - \int_b^a \vec{E} \cdot d\hat{r} = - \int_b^a \frac{\sigma_i a}{\epsilon_0 r} dr = - \frac{\sigma_i a}{\epsilon_0} \ln(r) \Big|_b^a = \frac{\sigma_i a}{\epsilon_0} \ln(b/a) \quad (1.154)$$

- Now we know the potential and it is trivial to obtain the capacitance:

$$C = \frac{Q}{V} = \frac{2\pi a L \sigma_i \epsilon_0}{\sigma_i a \ln(b/a)} = \frac{2\pi L \epsilon_0}{\ln(b/a)} \quad (1.155)$$

Like the plate-capacitor, the capacitance of this configuration increases when the distance between the two conductors becomes smaller.

Spherical Capacitor

We now consider a capacitor consisting of a spherical surface (thus not a massive sphere, but a shell with some thickness) of a conducting material with radius b . In its center we placed a conducting sphere with radius a . The conductors carry opposite charge Q . What is the capacitance of this

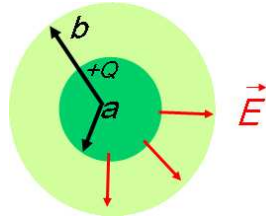

Figure 1.39: A spherical capacitors. The inner conductor has radius a and the outer one has radius b . The conductors have opposite charge. Note that the outer conductor is a spherical surface (a shell) and not a massive sphere.

configuration? To calculate the electrical field we use a spherical Gaussian surface with radius r such that $a < r < b$. For the electrical field we obtain:

$$\vec{E} = \frac{\sigma a^2}{\epsilon_0 r^2} \hat{r} \quad (1.156)$$

Now we calculate the potential difference between the conductors:

$$V = - \int_b^a \vec{E} \cdot d\hat{r} = - \int_b^a \frac{\sigma a^2}{\epsilon_0 r^2} dr = \frac{\sigma a^2}{\epsilon_0 r} \Big|_b^a = \frac{\sigma a^2}{\epsilon_0} \left(\frac{1}{a} - \frac{1}{b} \right) \quad (1.157)$$

for the capacitance follows:

$$C = \frac{Q}{V} = \frac{4\pi a^2 \sigma \epsilon_0}{\sigma a^2 (1/a - 1/b)} = 4\pi \epsilon_0 \frac{ab}{b - a} \quad (1.158)$$

Note that the capacitance is independent on V and/or Q and thus is indeed a purely geometrical quantity.

1.6.3 Knowledge and Skills

The knowledge and skills you should have acquired during reading of the previous can be summarized as follows:

- You understand the properties of a conductor.
- When a conductor is placed in an electrical field you can identify the surface charge densities and calculate the resulting electrical field.
- You understand the basics of the mirror charge technique
- You can explain what capacitors are and deduce the relation:

$$C = \frac{Q}{V} \quad (1.159)$$

- You can calculate the the capacitance of a parallel plate capacitor.
- The energy of a capacitor is given by

$$U = \frac{1}{2} CV^2 \quad (1.160)$$

In addition, make the corresponding exercises of this section, which you can find in the Appendix.

1.7 Insulators

All matter that cannot be classified as a conductor we call an insulator. In insulators there are no free electrons to cancel the electric field inside the 'bulk'. However, by polarization of the molecules and atoms inside an insulator there is some cancellation of the field. When an atom polarizes we can discriminate between a positive and negative side. For this reason, insulators are historically referred to as 'dielectrics'. The properties and behavior of dielectrics in electrical fields are discussed in this Section.

1.7.1 Polarization of atoms and molecules

What happens microscopically when we electrically polarize an atom? The classical picture of an atom is a big positive nucleus surrounded by tiny electrons orbiting it. For our purpose, that is electrostatics, we adapt this picture by taking the 'average' of the atom over time. Yes, you need some imagination, but this leads to an atom consisting of a small positive nucleus in the center of a uniform cloud of negative charge. Consider the illustration in Fig. 1.40. When we apply an external

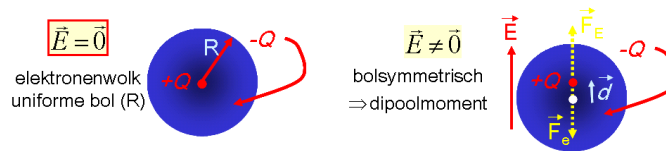

Figure 1.40: A view of an electrostatic atom. It consists of a positive nucleus surrounded by a uniform cloud of negative charge. The cloud has radius (R). Left: Unpolarized, the nucleus is centered; Right: Polarized, the nucleus is shifted away from the center of the cloud. This results effectively in a dipole.

electrical field E as is depicted in the right figure, the negative charge is attracted, while the positive nucleus is repelled. Consequently, the nucleus is shifted by a distance d with respect to the center of the cloud. We have assumed that the spherical shape of the cloud is conserved. The net effect is that we produced an electrical dipole with moment $\vec{p} = Q\vec{d}$.

To good approximation the dipole moment is proportional to the external field: $\vec{p} = Q\vec{d} = \alpha\vec{E}$, with proportionality factor α , called the 'polarizability'. Table 1.2 lists some experimentally obtained polarizabilities. As expected, the factor α grows with increasing charge Z . For water vapor

Atom	Z	α (10^{-30} m^3)
Helium	2	3
Neon	10	5
Argon	18	20
Water vapor	-	500

Table 1.2: Several examples of the polarizability for some atoms and water vapor.

we observe that α is relatively large. Such atypical behavior points in the direction of a different physical mechanism. Indeed, there is an additional effect in water vapor and other so called 'polar' molecules. The electrons in water molecules are attracted by the positive oxygen nucleus, more

than by the hydrogen nuclei. The result is that water (and other polar molecules) have a built in electrical dipole moment. Figure 1.41 shows what happens when these molecules are placed in an electrical field. The dipole moments of the water molecules are aligned by the external electrical

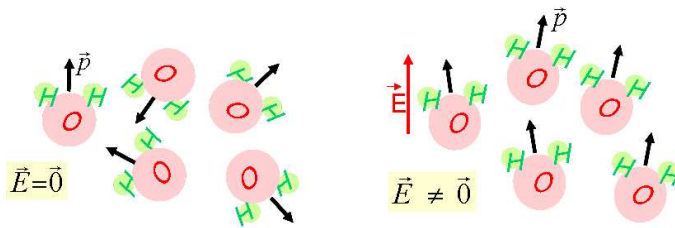

Figure 1.41: *Left: Water molecules without electrical field. the electrical dipole moment of the molecules is indicated. Right: Water molecules in an external electrical field. The dipole moment of the molecules are aligned by the electrical force.*

field which leads to the relatively large polarization factor α .

In this Section we have discussed two different microscopic effects leading to polarized matter. We have postulated a straightforward relation ($\vec{p} = \alpha\vec{E}$) between a new phenomenon called polarization in the external electrical field. In Electrostatics however, we do not care about this microscopic behavior so much. We only want to describe the behavior of the fields, averaged over all atoms, as we will see in the follow Section.

1.7.2 Macroscopic Polarization

What is the electrical field in a dielectric when put in a known external field? Forget for the moment the atoms and molecules in the dielectric and put on your 'abstract glasses'. In electrostatic theory, dielectrics consist of infinitesimally small electrical dipoles. A dielectric can be electrically polarized by putting it in an external field \vec{E}_0 as illustrated by Fig. 1.42.

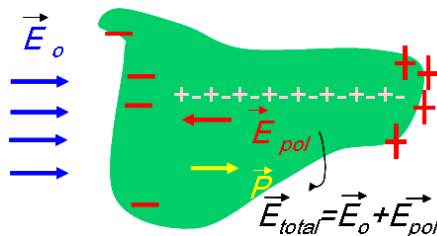

Figure 1.42: *A dielectric in an external electric field \vec{E}_0 . The microscopic dipoles polarize (polarization \vec{P}). The resulting total field is given by the sum of the original external field and that of the polarized dipoles.*

Inspired by the microscopic view (see previous Section), the polarization per unit volume is defined as the polarization \vec{P} which we *assume* proportional to the electrical field:

$$\vec{P} = \epsilon_0 \chi_e \vec{E} \quad (1.161)$$

The factor of proportionality χ_e is called the electrical susceptibility for historical reasons. We say that the dielectric is *linear* when this equation is valid. In general it is valid for relatively small

electrical fields. Note that the word linear in this context is not related to shape of the dielectric; it describes an electrical property. In this expression, the electrical field $\vec{E} = \vec{E}_{total}$, the total field, which usually leads to confusion and/or mistakes! It is the sum of the external field and the, yet unknown, field from the polarized dipoles (\vec{E}_{pol}).

What is the field of the polarized dipoles? Well, the polarization leads to net charge separation. When we can quantify this charge, that is, determine the charge configuration, we know how to calculate the field using standard techniques. So, let's try to find the charge density inside a dielectric first.

Have another look at Fig. 1.42. Inside the the dielectric there is macroscopically no net charge. The dipoles are aligned in chains of positive and negative charge and all the '+' are canceled by '-'. However, this is not the case at 'the start and end of the chains', at the boundary of the dielectric. At the left side, all the chains start with '-', while at the right side all chains end with '+'. There is a net charge separation at the surface of the dielectric. Note that the charges themselves are localized in contrast with the free charge in a conductor. For this reason, the net charge at the surfaces of a dielectric is called *bound* charge. The amount of bound charge is given by the polarization:

$$\sigma_{bound} = \vec{P} \cdot \hat{n} \quad (1.162)$$

Let's put in a small intermezzo. The above Equation 1.162 is sufficient for linear dielectrics; there cannot be any bound charge inside the dielectric. However, more generally the relation between polarization and charge is given by:

$$\rho_{bound} = -\vec{\nabla} \cdot \vec{P}. \quad (1.163)$$

It says that there is bound charge inside an dielectric when the polarization inside a dielectric is not constant. In such case there is no (perfect) cancellation between positive and negative bound charge inside the dielectric in contrast to a linear dielectric. At the surface of any dielectric this relation transforms to Equation 1.162. In this reader, like in many textbooks, we further only consider linear dielectrics, unless stated otherwise. This ends our small intermezzo.

In principle, we can now deal with a dielectric (with known χ_e) placed in a known original external field E_0 :

- 1 the (yet unknown) polarization P determines the (bound) charge configuration (Equation 1.162),
- 2 the charge configuration determines the contribution E_{pol} to the electrical field, enabling us to calculate E_{total} ,
- 3 E_{total} fixes the polarization (Equation 1.161).

To you, it all may look a bit circular, but in the following Sections we will discuss some examples. There is one suggestion to consider: memorize the three Equations above (and their meaning)!

The electrical field in a flat dielectric

We consider a flat dielectric with a given χ_e and we place it in a known uniform electrical field \vec{E}_0 in the z direction as shown in Fig. 1.43. The dipoles in the dielectric polarize, leading to a polarization \vec{P} . The bound net charge on the surfaces of the dielectric is according to Equation 1.162:

$$\sigma_b = \vec{P} \cdot \hat{n} = \vec{P} \quad (1.164)$$

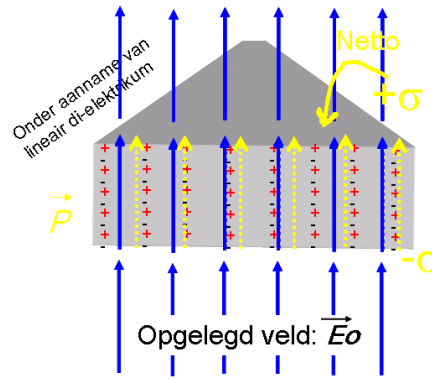

Figure 1.43: A piece of dielectric in an external electric field \vec{E}_0 . The microscopic dipoles polarize (polarization \vec{P}). The resulting bound charge at the surface is also indicated.

Now, forget about the dielectric and only use the equivalent configuration. Hence, besides \vec{E}_0 , we have a configuration of two oppositely charged flat surfaces, which leads to an electrical field:

$$\vec{E}_{pol} = \frac{-\sigma_{pol}}{\epsilon_0} \hat{z} \quad (1.165)$$

Here we simply used the formula of a plate capacitor, derived in Section 1.6.2 (but I am sure, you could derive it yourself by now).

In the dielectric, the (total) electrical field is now:

$$\begin{aligned} \vec{E} &= \vec{E}_0 + \vec{E}_{pol} \\ &= \vec{E}_0 - \sigma_{pol} / \epsilon_0 \\ &= \vec{E}_0 - \vec{P} / \epsilon_0 \end{aligned} \quad (1.166)$$

Using equation 1.161 we can write

$$\vec{E} = \vec{E}_0 - \chi_e \vec{E} = \frac{1}{(\chi_e + 1)} \vec{E}_0 \quad (1.167)$$

That's it!

The susceptibility χ_e for glass and plastic like are of order 10. For water the susceptibility is about 80.

Plate capacitor with dielectric

Consider a plate capacitor with a dielectric in between its plates as illustrated in Fig. 1.44. The plates have surface A and are separated by a distance d . The dielectric has an electrical susceptibility χ_e . Given the free charge Q_{free} on the plates, what is the electrical field in the dielectric and what is the capacitance of this capacitor?

That looks like a tough question, but in fact it isn't. Just cut the problem in relevant pieces and you will see that you already can solve all pieces one by one.

Starting point, the first piece, is an *empty* capacitor. Thus the same configuration as already discussed in Section 1.6.2. We repeat our results (you should be able to derive these results by

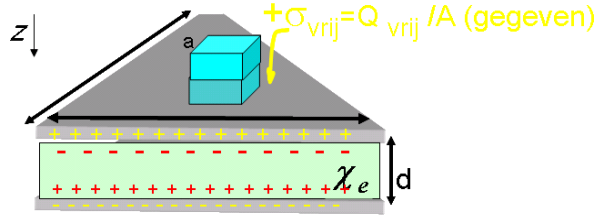

Figure 1.44: A plate capacitor with dielectric in between the plates.

now):

$$\begin{aligned}\vec{E}_{empty} &= \frac{Q_{free}}{A\epsilon_0} \hat{z} = \frac{\sigma_{free}}{\epsilon_0} \hat{z} \\ V_{empty} &= - \int_{-}^{+} \vec{E}_{empty} \cdot dz = \frac{d}{A\epsilon_0} Q_{free} \\ C_{empty} &= \frac{Q_{free}}{V_{empty}} = \frac{\epsilon_0 A}{d}\end{aligned}\quad (1.168)$$

The second step is to place the dielectric between the plates. The field inside the empty capacitor is relevant external field for the dielectric. In fact we have placed a dielectric in an external field just like we have already seen in the previous Section and according to equation 1.167 the field becomes:

$$\vec{E} = \frac{1}{(\chi_e + 1)} \vec{E}_{empty} = \frac{1}{(\chi_e + 1)} \frac{\sigma_{free}}{\epsilon_0} \hat{z}\quad (1.169)$$

So-far, so good and we go to the next piece. We can calculate the potential between the plates by integration of the electrical field (just like we have done for empty capacitors):

$$V = - \int_{-}^{+} \vec{E} \cdot dz = \frac{1}{(\chi_e + 1)} \frac{d}{A\epsilon_0} Q_{free} = \frac{1}{(\chi_e + 1)} V_{empty}\quad (1.170)$$

for the capacity follows:

$$C = \frac{Q_{free}}{V} = (\chi_e + 1) \frac{\epsilon_0 A}{d} = (\chi_e + 1) C_{empty}\quad (1.171)$$

In textbooks the following definition is often used

$$(\chi_e + 1)\epsilon_0 = \epsilon\quad (1.172)$$

With this definition most expression related to dielectrics become similar as the expression in vacuum after substituting ϵ for ϵ_0 .

Note that the capacitance between the empty and 'filled' capacitor is just the factor $(\chi_e + 1)$. Thus, for plastic fillings the capacity grows with a factor of order ten.

1.7.3 The electrical Displacement

To describe electrical fields inside dielectrics, we had to throw in several new 'electrostatic objects' like the polarization P and the bound charge, ρ_b . The question may arise: is Gauss' Law valid inside

a dielectric or should it be adapted? The answer is that Gauss' Law is always valid, but we should be careful. Consider Gauss's Law once more:

$$\epsilon_0 \vec{\nabla} \cdot \vec{E} = \rho \quad (1.173)$$

Realize that \vec{E} in Gauss' Law always is the *total* electrical field and ρ is the *total* charge density:

$$\epsilon_0 \vec{\nabla} \cdot \vec{E} = \rho_{free} + \rho_b \quad (1.174)$$

where ρ_{free} is the charge induced on an conductor surface or the charge needed to create an external electrical field. (Keep in mind that we often discussed examples where we put a dielectric in an external field. Well, the external field comes not for free: it is the effect of free charge somewhere.) Using Equation 1.163 we can write:

$$\epsilon_0 \vec{\nabla} \cdot \vec{E} = \rho_{free} - \vec{\nabla} \cdot \vec{P} \quad (1.175)$$

or equivalently,

$$\vec{\nabla} \cdot (\epsilon_0 \vec{E} + \vec{P}) = \rho_{free} \quad (1.176)$$

Now define the dielectric displacement $\vec{D} = \epsilon_0 \vec{E} + \vec{P}$. It is just a matter of definition, but \vec{D} has an important feature:

$$\vec{\nabla} \cdot \vec{D} = \rho_{free} \quad (1.177)$$

It is Gauss' Law for 'field' \vec{D} that only depends on the presence of free charge. Also the integral form of Gauss' Law is valid:

$$\int_{closed-surface} \vec{D} \cdot d\vec{o} = \sum_{free-charges-enclosed} \frac{Q_i}{\epsilon_0} \quad (1.178)$$

Combining the formula's in this Section you can derive that \vec{D} is also proportional to the (total) field \vec{E} :

$$\vec{D} = \epsilon \vec{E} + \vec{P} = \epsilon \vec{E} + \epsilon \chi \vec{E} = (\chi_e + 1) \epsilon_0 \vec{E} = \epsilon \vec{E} \quad (1.179)$$

This mathematical approach completes the theory on electrical fields in matter.

1.7.4 Knowledge and Skills

The knowledge and skills you should have acquired during reading of the previous can be summarized as follows:

- You can explain how a dielectric is polarized in an electrical field, resulting in a net bound charge at its surface.
- The relation between the polarization and the electrical field is

$$\vec{P} = \epsilon_0 \chi_e \vec{E} \quad (1.180)$$

- With this relation you can calculate the electrical field in a parallel plate capacitor filled with a dielectric:

$$\vec{E} = \frac{1}{(\chi_e + 1)} \vec{E}_{empty} = \frac{1}{(\chi_e + 1)} \frac{\sigma_{free}}{\epsilon_0} \hat{z} \quad (1.181)$$

You can also show that the capacitance is:

$$C = (\chi_e + 1) C_{empty} \quad (1.182)$$

The capacitance of the filled capacitor is larger than that of the empty capacitor.

In addition, make the corresponding exercises of this section, which you can find in the Appendix.

1.8 The icons of Electrostatics

Throughout the previous Sections we deduced, described, discussed and derived the aspects of electrical fields in vacuum and matter. The resulting field equations are listed in Table 1.3. Never forget that we started with Coulomb's empirical Law, based on experiment and constructed the theory on electrostatics around it.

Comment	Integral	Differential
Gauss	$\int_{surface} \vec{E} \cdot d\vec{\sigma} = \int_{volume} \frac{\rho}{\epsilon_0} dv$ $\int_{closed-line} \vec{E} \cdot d\vec{l} = 0$	$\vec{\nabla} \cdot \vec{E} = \frac{\rho}{\epsilon_0}$ $\vec{\nabla} \times \vec{E} = \vec{0}$

Table 1.3: *The complete set of field equations for electrostatic theory.*

Chapter 2

Magnetostatics

2.1 Basic concepts

Magnetostatics aims at the description of all phenomena that involve non-changing magnetic fields. Qualitative knowledge about magnetostatics has been around for many centuries: it is possible to use a magnet needle to make a compass without knowing how to quantify magnetic processes. In this section some basic concepts of magnetism are discussed.

In electrostatics you are familiar with the fact you have positive and negative charges. The charges for magnetostatics always come in pairs. In a magnet one side is the magnetic-positive side, while the other side is the magnetic-negative side. The magnetic-positive side we like to call the 'north-pole' and the magnetic-negative side the 'south-pole'. Of course this naming is derived from our own earth, which itself is a permanent magnet. Forces between magnets are such that a north- and a south pole attract each other, while there is a repelling force between two poles of the same kind.

Now you could decide to cut a magnet in half, just between the north- and the south pole, in order to obtain a north-pole and a south-pole separately. The result of your experiment, however, will be that you will have indeed two magnets, both with a north AND a south pole (see Fig. 2.1). You can repeat this as many times as you like, but the only thing you will succeed in, is to get many more small magnets. As far as we know no magnetic monopoles exist!

Also it is well known that compared to gravity the magnitude of the magnetic force is huge. It is very common for even small magnets to lift little (or sometimes big) pieces of iron, against the gravitational force from the whole earth!

In addition there exists an intricate relation between electrical currents and magnetic field, which will become clear further in these lecture notes. The unit of a magnetic field is called the Tesla, and it can be described in terms of other units as:

$$[Tesla] = [N]/([A][m]) = [N][s]/([C][m]) = [kg]/([C][s]) \quad (2.1)$$

with $[A] = [C]/[s]$ an electrical current, and $[N]$ the unit of force.

2.2 Lorentz force

2.2.1 Experimental basis and formulation

The Dutch physicist Hendrik Antoon Lorentz was the first to quantify the movement of an electrically charged particle inside a constant magnetic field. Just as Coulomb's law that describes forces

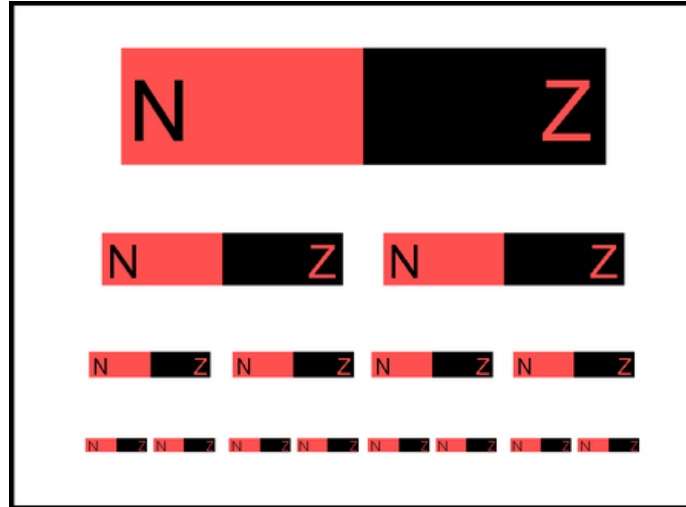

Figure 2.1: Cutting a magnet in two pieces will only result in creating two magnets, each with a magnetic north- and south pole. You can repeat cutting, but you will not create a magnetic monopole.

in electrostatics, the law for the force caused by a magnetic field is based on experimental data:

1. The Lorentz force is proportional to the strength of the magnetic field;
2. The Lorentz force is proportional to the electric charge;
3. The Lorentz force is proportional to the velocity of the object it acts on;
4. The Lorentz force is proportional to the sine of the angle between the velocity vector and the speed vector;
5. The Lorentz force is perpendicular to both the velocity direction and the direction of the magnetic field;

This list of experimental data can be elegantly translated into the following mathematical statement, that fully describes the force of a magnetic field \vec{B} on a moving object with charge q and a velocity \vec{v} :

$$\vec{F} = q\vec{v} \times \vec{B} \quad (2.2)$$

The \times in equation 2.2 represents the 'cross-product' between two vectors. With our knowledge of the cross product we can prove that the Lorentz force actually obeys the experimental data as listed above. The magnitude of the Lorentz force is given by:

$$\begin{aligned} |\vec{F}| &= q|\vec{v} \times \vec{B}| \\ &= q|\vec{v}||\vec{B}|\sin\theta \end{aligned} \quad (2.3)$$

with θ the angle between the magnetic field lines and the velocity vector. From the last equation it can be seen that the first four experimental requirements on the Lorentz force have been fulfilled.

2.2.2 The direction of the Lorentz force

When it comes to proving that the Lorentz force fulfills the last requirement things are slightly more complicated, since we now have to calculate the *direction* of the force. Remember that for electrostatics the electrical force was just proportional to the size and direction of the electrical field. For the Lorentz force this is not the case, since we are dealing with a cross-product of two vectors. Now we have to look into the detail of the cross-product: what is the direction of the result vector? First we will work out mathematically what is the direction of the field. The cross product between any two vectors $\vec{v} = (v_x, v_y, v_z)$ and $\vec{B} = (B_x, B_y, B_z)$ can be calculated by evaluating the following determinant (try this yourself and you will be a commander of cross-products!):

$$\begin{aligned}\vec{v} \times \vec{B} &= \begin{vmatrix} \hat{x} & \hat{y} & \hat{z} \\ v_x & v_y & v_z \\ B_x & B_y & B_z \end{vmatrix} \\ &= (v_y B_z - v_z B_y) \hat{x} + (v_z B_x - v_x B_z) \hat{y} + (v_x B_y - v_y B_x) \hat{z} \\ &= \begin{pmatrix} v_y B_z - v_z B_y \\ v_z B_x - v_x B_z \\ v_x B_y - v_y B_x \end{pmatrix}\end{aligned}\quad (2.4)$$

This general equation might not tell the full story of the direction of the Lorentz force directly, but we can prove that the direction of the force is both perpendicular to the velocity vector and the magnetic field vector. Two vectors are perpendicular if their *inner product* equals zero (remember: $\vec{A} \cdot \vec{B} = |\vec{A}||\vec{B}|\cos\theta$), so we have to validate that:

$$\vec{F} \cdot \vec{v} = 0 \quad (2.5)$$

We can explicitly calculate the inner product using equation 2.4 as follows:

$$\begin{aligned}\vec{F} \cdot \vec{v} &= q(\vec{v} \times \vec{B}) \cdot \vec{v} \\ &= q(v_y B_z - v_z B_y) v_x + \\ &\quad q(v_z B_x - v_x B_z) v_y + q(v_x B_y - v_y B_x) v_z \\ &= qB_x(v_z v_y - v_y v_z) + qB_y(-v_z v_x + v_z v_y) + qB_z(v_y v_x - v_x v_y) \\ &= 0\end{aligned}\quad (2.6)$$

Following similar tactics you can now prove yourself that the Lorentz force is also perpendicular to the magnetic field. In fact you then have proved a general property of cross-products between vectors \vec{A} and \vec{B} :

$$\vec{A} \cdot (\vec{A} \times \vec{B}) = 0 \quad (2.7)$$

$$\vec{B} \cdot (\vec{A} \times \vec{B}) = 0 \quad (2.8)$$

Note that the second statement follows directly from the first, because of another property of the cross-product:

$$\vec{A} \times \vec{B} = -\vec{B} \times \vec{A} \quad (2.9)$$

Prove this!

2.2.3 A force without work

A very important consequence of the fact that the Lorentz force is perpendicular to the velocity of an object, is that the Lorentz force does not do any work. To understand this a bit more in detail we have to recall our definition of work W being done by a force. It has been defined as the displacement in the direction of the force, or as an equation:

$$W = \int_{\text{line}} \vec{F} \cdot d\vec{l} \quad (2.10)$$

This can be rewritten with a change of variables as:

$$W = \int_{\text{line}} \vec{F} \cdot \vec{v} dt \quad (2.11)$$

The last equation is clearly zero due to equation 2.5. The consequence of this is that if a charged particle moves through a magnetic field its energy does not change, since that requires work done. So the only thing that does change is the *direction* of the velocity. This is really special to the Lorentz force: all other forces you have thus far encountered, like the Coulomb force or gravitational force, do actually work.

2.2.4 The right-hand-rule

Now it is time to get a clearer understanding of the direction of the Lorentz force by studying a simple example. Let's look at a configuration with a magnetic field $\vec{B} = (0, 0, B)$ pointing in the \hat{z} direction and a particle with charge q moving with velocity $\vec{v} = (v, 0, 0)$ in the \hat{x} direction. The equation now becomes much more explicit and clear:

$$\vec{F} = -qvB\hat{y} \quad (2.12)$$

You can verify that all requirements on the Lorentz force as mentioned before are still fulfilled ($\sin \frac{\pi}{2} = 1!$) and also you can see that the direction of the Lorentz force can be obtained without calculation, by using the (in)-famous 'right hand rule'. Stretch out your hand and make your thumb point in the direction of \vec{v} . Point your other fingers in the direction of the magnetic field \vec{B} . The cross-product $\vec{v} \times \vec{B}$ is now pointing out of the palm of your hand. Exercise this a couple of times and you will never make any mistakes in pointing out the direction of cross-product. Be however careful that a negative electric charge does flip the direction of the Lorentz force by 180° .

2.2.5 Example: force on a wire

What happens if you place a wire of length L carrying a current I , inside a homogeneous magnetic field, B (see Fig. 2.2)? The direction of the force can be found using the right hand rule. The electrons move in the opposite direction as the current, but they have a negative charge. So the direction of the force is the direction of the cross product of \vec{I} and \vec{B} . The size of the force is calculated by integrating:

$$\begin{aligned} |\vec{F}| &= \int_{\text{line}} dq(\vec{v} \times \vec{B}) \\ &= \int_{\text{line}} \lambda dl(\vec{v} \times \vec{B}) \\ &= \int_{\text{line}} dl(\vec{I} \times \vec{B}) \\ &= LIB \end{aligned} \quad (2.13)$$

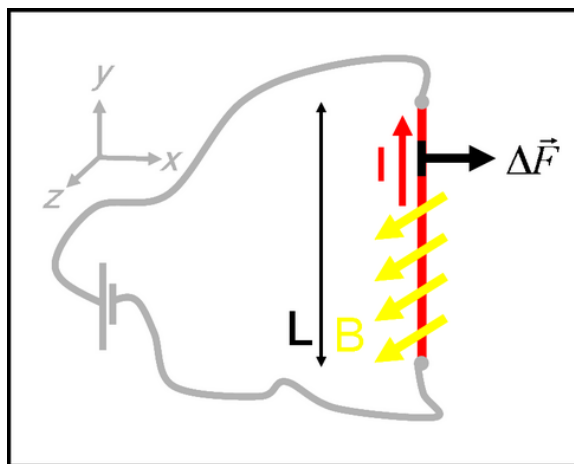

Figure 2.2: A wire with length L is placed inside a homogeneous magnetic field B with field lines pointing out of the paper.

We have used the fact that the line charge density λ multiplied by the velocity of the electrons gives the electrical current I . So we now have an equation that tells us that the Lorentz force of a magnetic field on a wire carrying a current I is equal to:

$$d\vec{F} = dl(\vec{I} \times \vec{B}) \quad (2.14)$$

2.2.6 Current loops & Magnetic dipoles

Now let us consider a square wire loop with sides of length L carrying a current I , placed in a homogeneous magnetic field \vec{B} (see Fig. 2.3). The forces on each of the sides of the loop can be

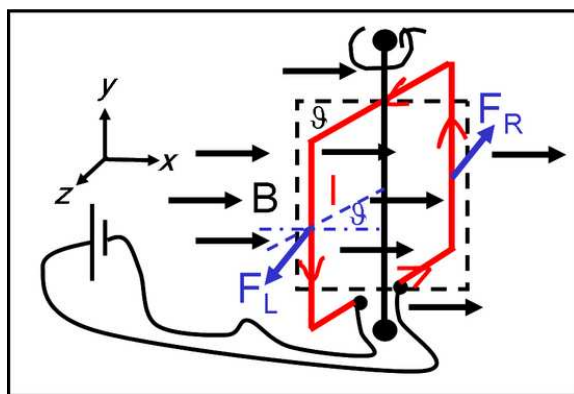

Figure 2.3: A square wire loop with sides L and carrying a current I is placed inside a homogeneous magnetic field B .

calculated in the same way as shown in the previous paragraph:

$$\vec{F} = L(\vec{I} \times \vec{B}) \quad (2.15)$$

It can be seen that the net force on the wire loop is zero, since the forces on top and bottom of the loop cancel each other, just as the forces on both of the sides. However, there is a *torque* on the current loop! The torque, τ , exerted on for example the left side of the loop is just the size of the Lorentz force times the 'arm' the force. So:

$$\tau_L = (LIB) \frac{L}{2} \sin \theta \quad (2.16)$$

In the right side of the loop the Lorentz force points in the opposite direction, but the arm of the force also points in the opposite direction. So the total torque becomes:

$$\tau = L^2 IB \sin \theta \quad (2.17)$$

Notice that the bottom and top sides of the current loop do not contribute to the torque. The Lorentz force is certainly pulling of the wire there as well, but it is trying to stretch the wire loop instead of trying to rotate it (try to understand this yourself).

At this point it is instructive to rewrite equation 2.17 as the following cross-product:

$$\vec{\tau} = \vec{m} \times \vec{B} \quad (2.18)$$

where \vec{m} is the *magnetic dipole moment* of the current loop. The direction of the magnetic dipole moment is perpendicular to the plane spanned by the wire loop. Its size is just the current multiplied by the surface area:

$$|\vec{m}| = L^2 I \quad (2.19)$$

The torque exerted on the wire loop tries to rotate it such that it is perpendicular to the magnetic field lines. In terms of a magnetic dipole moment we can make a more general statement: a magnetic field tries to set magnetic dipoles parallel to the magnetic field lines.

2.3 Biot-Savart's law

Now we have learned in the previous section how to calculate the force exerted by a magnetic field on a moving charge, we have to know how to actually calculate a magnetic field. Magnetic fields are caused by electric currents. An expression that relates the magnetic field, \vec{B}_P , in a point P to an electric current, I , is called the law of Biot-Savart:

$$\vec{B}_P = \frac{\mu_0 I}{4\pi} \int_{\text{line}} \frac{d\vec{l} \times \hat{r}}{r^2} \quad (2.20)$$

The integration is done along the current path in the direction of the flow; $d\vec{l}$ is an element of length along the wire and \hat{r} is the direction vector from the location of $d\vec{l}$ and the point P as is sketched in Fig. 2.4. Try to verify by using the right-hand-rule that the magnetic field due to the infinitesimal wire element in Fig. 2.4 is pointing into the paper. When using Eq. 2.20 you should realize that along your integration path both $d\vec{l}$, \hat{r} , and r may change, both in magnitude and direction! To master this equation practice is mandatory.

The constant μ_0 is called the magnetic permeability which is defined as:

$$\mu_0 \equiv 4\pi \cdot 10^{-7} \frac{N}{A^2} \quad (2.21)$$

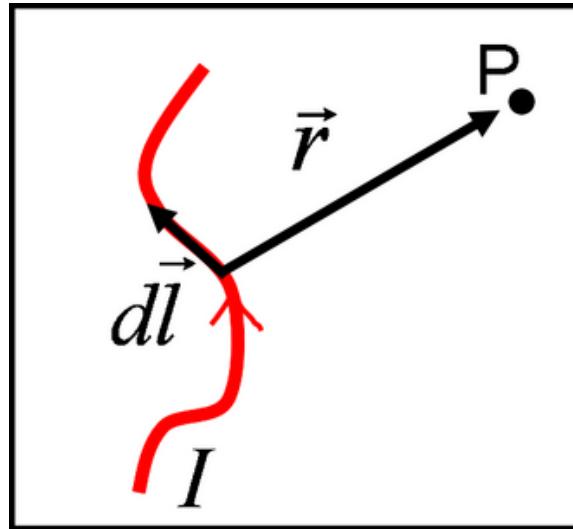

Figure 2.4: Variables needed to calculate the magnetic field in a point P due to an infinitesimal wire element with length $d\vec{l}$ at a distance \vec{r} .

A remarkable thing happens when the magnetic permeability is multiplied with the electrical permittivity ϵ_0 . Remember that ϵ_0 was defined as:

$$\epsilon_0 \equiv \frac{1}{4\pi \cdot 10^{-7} c^2 \text{ Nm}^2} \quad (2.22)$$

The multiplication leads to:

$$\frac{1}{\epsilon_0 \mu_0} = c^2 \quad (2.23)$$

with c the speed of light. This amazing results indicates that there might be a special relationship between electric and magnetic field. This relationship will be unveiled toward the end of this course.

2.3.1 A wire with a current

With Biot-Savart's law we are now able to calculate the magnetic field for any current configurations. So let us start with the calculation of the magnetic field of a relatively simple example: an infinitely long wire carrying a current I (see Fig. 2.5). We could start calculating like blind chickens at this point, but we can also use *symmetry* arguments to argue what the direction of the field must be. The cylindrical symmetry of this example excludes the existence of a radial component to the magnetic field. We can try to argue that this is impossible by making a 'gedanken' experiment: we can rotate the infinitely long wire by 180° so the current is now pointing in the downward direction. As can be seen in the law of Biot-Savart changing the sign of the current would result in flipping the sign of the \vec{B} field. However, the rotation of the wire leaves the radial component of the magnetic field pointing in the same direction as before. So there can exist no radial magnetic field in our example. The component of the magnetic field pointing *along* the direction of the wire drops out because the contribution coming from the current at $z < 0$ is canceled exactly by the contribution from the current at $z > 0$ (try to prove and visualize this yourself).

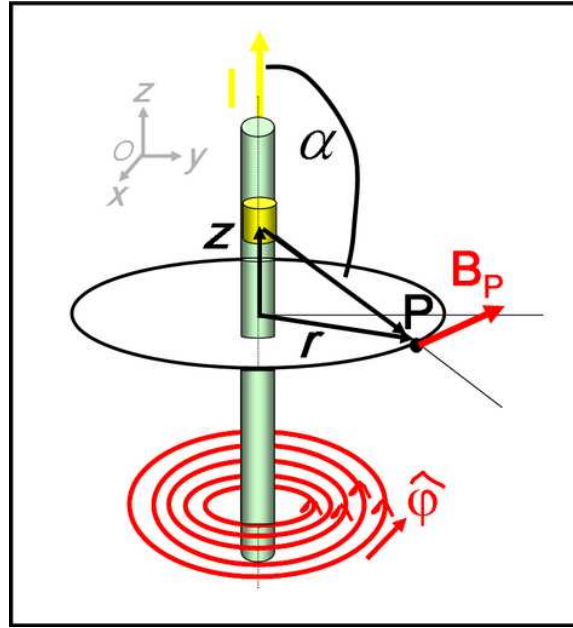

Figure 2.5: Wire carrying a current I . The magnetic field is calculated at a point P at a distance r from the wire.

So the only component of the magnetic field that is not equal to zero is the component in the azimuthal, ϕ , direction. Its size is calculated with Biot-Savart's law 2.20, but we have to be extremely careful how to fill in the variables in the equation. Let us consider the magnetic field caused by an infinitesimal line element $d\vec{z}$ first (see Fig. 2.5): the magnitude of the magnetic field in point P due to this line element is:

$$|d\vec{B}_P| = \frac{\mu_0 I |d\vec{z}| \sin \alpha}{4\pi r^2 + z^2} \quad (2.24)$$

There are a couple of variables in this equation that at first might seem a bit strange. First there is the $r^2 + z^2$ term, while you would expect a r^2 term if you look at the Biot-Savart law. But in fact the $r^2 + z^2$ is correct since it is the distance between the line element $d\vec{z}$ and the point P . So the r in Biot-Savart's law is a very different r than is used to indicate the radius in cylindrical coordinates. The same is the case for \hat{r} which indicates the unit vector in the direction of the line element $d\vec{z}$ and the point P , and thus also has nothing to do with the radius in cylindrical coordinates. You must think very well before just using a formula! The $\sin \alpha$ comes from the size of the cross product:

$$|d\vec{z} \times \hat{r}| = dz \sin \alpha \quad (2.25)$$

where α is the angle between $d\vec{z}$ and \hat{r} . It can be geometrically worked out to be:

$$\sin \alpha = \frac{r}{\sqrt{r^2 + z^2}} \quad (2.26)$$

Now we can calculate the magnetic field adding the contributions from all line elements to the magnetic field.

$$|\vec{B}_P| = \left| \int_{\text{line}} d\vec{B}_\phi \right|$$

$$\begin{aligned}
&= \frac{\mu_0 I}{4\pi} \int_{-\infty}^{+\infty} \frac{dz}{r^2 + z^2} \frac{r}{\sqrt{r^2 + z^2}} \\
&= \frac{\mu_0 I}{4\pi} \frac{z}{r\sqrt{r^2 + z^2}} \Big|_{-\infty}^{+\infty} \\
&= \frac{\mu_0 I}{2\pi r} \tag{2.27}
\end{aligned}$$

The integral over z you do not have to be able to solve yourself. If you encounter such an integral at any point we will provide you with the answer. However you can verify the answer by differentiating the one but last equation.

2.3.2 Two parallel wires

We can now consider a configuration with two parallel wires with length L at a distance \vec{R}_{12} each carrying an electrical current, I_1 and I_2 , respectively (see Fig. 2.6). We can calculate the magnetic field at the position of the second wire, due to the current in the other wire using equation 2.27. The

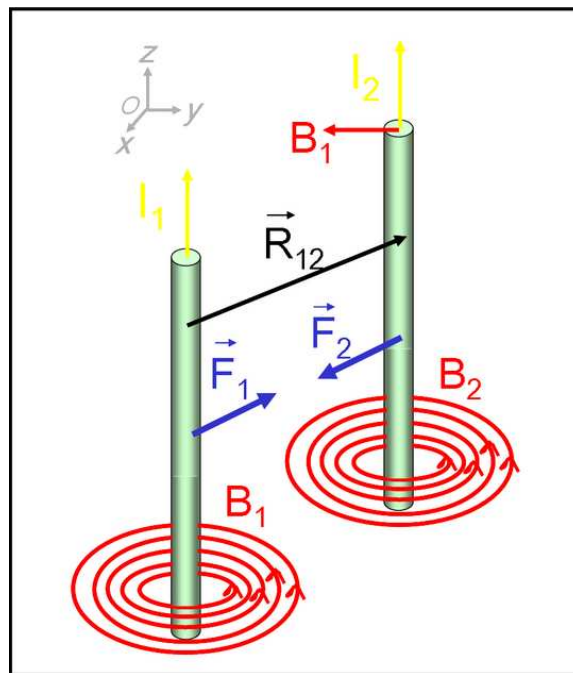

Figure 2.6: Two wires with electric currents both generate a magnetic field. The magnetic fields result in a Lorentz force on the wires.

equation for the Lorentz force on a wire (Eq. 2.13) tells us that:

$$|\vec{F}_2| = L |(\vec{I}_2 \times \vec{B}_1)| \tag{2.28}$$

$$= \frac{\mu_0 L I_2 I_1}{2\pi R_{12}} \tag{2.29}$$

The calculation of the size of the cross product is fairly easy since there are only 90° angles involved in this example. I leave it up to you to show that the Lorentz force between the wires is attractive if the currents point in the same direction.

2.3.3 Knowledge and Skills

The knowledge and skills you should have acquired during reading of the previous can be summarized as follows:

- Magnets always have a north- and a south pole. Magnetic monopoles do not exist;
- The Lorentz force of a magnetic field on a moving charge is:

$$\vec{F}_L = q\vec{v} \times \vec{B} \quad (2.30)$$

Make sure you can figure out both the *size* and the *direction* of the Lorentz force. For the direction make sure that you are comfortable with the right-hand-rule;

- The Lorentz force on a straight wire segment is:

$$\vec{F} = L(\vec{I} \times \vec{B}) \quad (2.31)$$

;

- The torque on a current loop is:

$$\tau = \vec{m} \times \vec{B} \quad (2.32)$$

where \vec{m} is the magnetic dipole moment;

- The law of Biot-Savart can be used to calculate magnetic fields that are caused by line currents:

$$\vec{B}_P = \frac{\mu_0 I}{4\pi} \int_{\text{line}} \frac{d\vec{l} \times \hat{r}}{r^2} \quad (2.33)$$

2.4 Intermezzo: Current densities

In the previous section we used currents all the time. Just as for electric charges it is often instructive to talk about current densities instead of currents. We can speak of *line*, *surface*, and *volume* current densities (see Fig. 2.7). A line current is defined as the charge density per meter, λ , times the

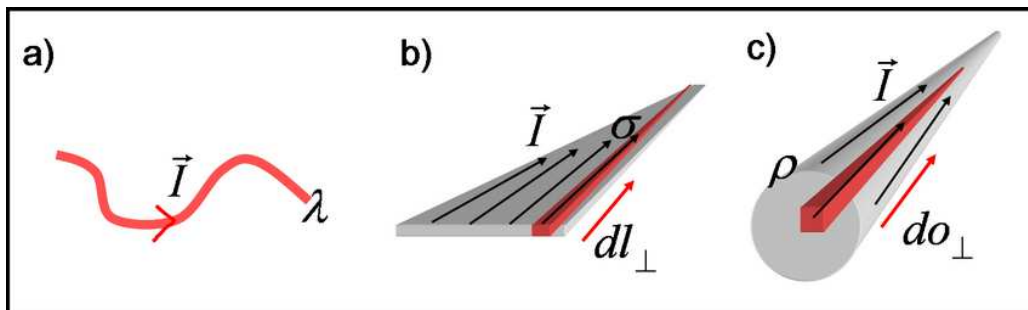

Figure 2.7: Different types of current densities: a) shows a line current density, b) a surface current density, and c) shows volume current density.

velocity of the charges:

$$\vec{I} = \lambda \vec{v} \rightarrow [I] = C/s = A \text{ (Ampere)} \quad (2.34)$$

The size of the current is just the magnitude of the vector \vec{I} . The corresponding Lorentz forces are calculated as:

$$\vec{F}_L = \int_{\text{line}} \vec{I} \times \vec{B} dl = I \int_{\text{line}} \vec{I} \times \vec{B} \quad (2.35)$$

For surface currents the situation is similar (see Fig. 2.7b):

$$\vec{K} \equiv \frac{d\vec{I}}{dl_{\perp}} \rightarrow [K] = A/m \quad (2.36)$$

$$= \sigma \vec{v} \quad (2.37)$$

To obtain a current one now has to multiply the surface current density, \vec{K} , with the length of the surface. Or to be more precise one has to integrate the current density along a surface if the current density is not a constant. The Lorentz force is now:

$$\vec{F} = \int_{\text{surface}} \vec{K} \times \vec{B} do \quad (2.38)$$

Biot-Savart's law can be used again to calculate the magnetic field resulting from a surface current density:

$$\vec{B} = \frac{\mu_0}{4\pi} \int_{\text{surface}} \frac{\vec{K}(\vec{r}') \times \hat{d}}{d^2} do' \quad (2.39)$$

where the integration is over the surface carrying the current, and $\vec{d} = \vec{r} - \vec{r}'$.

Most frequent you will encounter volume currents, \vec{J} , which are defined as:

$$\vec{J} \equiv \frac{d\vec{I}}{do_{\perp}} \rightarrow [J] = A/m^2 \quad (2.40)$$

$$= \rho \vec{v} \quad (2.41)$$

The differentiation with respect to do_{\perp} gives a vector pointing through a surface: the size of \vec{J} is the current per unit area perpendicular to the flow. For example take a wire with radius R and a current I . If we now assume that the current density is homogeneous, we can obtain the current density \vec{J} , by simply dividing I by the surface πR^2 of the wire. The direction of \vec{J} is along the direction of current flow. The Lorentz force can be calculated through the volume integral:

$$\vec{F} = \int_{\text{volume}} \vec{J} \times \vec{B} dV \quad (2.42)$$

Try to prove this last equation yourself. Once more Biot-Savart's law can be used to calculate the magnetic field resulting from a volume current density:

$$\vec{B} = \frac{\mu_0}{4\pi} \int_{\text{volume}} \frac{\vec{J}(\vec{r}') \times \hat{d}}{d^2} dV' \quad (2.43)$$

where the integration is over the volume carrying the current, and $\vec{d} = \vec{r} - \vec{r}'$.

2.5 Ampere's law

We now know how to calculate magnetic fields in any configuration using the Biot-Savart law in principle. We can have a closer look at the properties of magnetic fields to see if there are laws,

like Gauss's law for electrical fields, that can simplify our calculation of magnetic fields in certain cases. Let us go back to the magnetic field of a wire carrying a current:

$$B_\phi = \frac{\mu_0 I}{2\pi r}, B_r = B_z = 0 \quad (2.44)$$

We can take a circular path around the wire, so that the line integral:

$$\int_{\text{line}} \vec{B} \cdot d\vec{l} = \mu_0 I \quad (2.45)$$

where the \int represents an integral in a path around the wire. In fact the path does not have to be a circle; any path around the wire will give exactly the same answer (can you prove this one? see Griffiths section 5.3.1). We can generalize this law a bit further to obtain:

$$\int_{\text{line}} \vec{B} \cdot d\vec{l} = \mu_0 \int_{\text{surface}} \vec{J} \cdot d\vec{o} \quad (2.46)$$

This equation is known as the law of Ampere: it states that the integral of the magnetic field along a closed path is equal to the total current that is enclosed by the path. We have seen that it is true for a thin wire carrying a current. It can be explicitly proven, using the Biot-Savart law and the superposition principle, that it is true in general for any current density causing a magnetic field. (see Griffiths section 5.3.2).

The law of Ampere is always true, but for calculation of magnetic fields it is useful only if there is a high degree of *symmetry* in the configuration you want to solve. The reason for this is that in that case the line integral $\int \vec{B} d\vec{l}$ can become easy to solve. This is especially true if you know that the magnetic field over your integration path is constant, since the magnetic field then drops out of the integral, or in an equation:

$$\int_{\text{line}} \vec{B} d\vec{l} \rightarrow \vec{B} \int_{\text{line}} d\vec{l} \quad (2.47)$$

In the next sections we show a selection of examples where the magnetic fields can be calculated in a fairly easy way, using the law of Ampere.

2.5.1 Thick wire with a current

In the previous section you have already seen how Ampere's law can be used to calculate the magnetic field outside a wire. Now let us consider a wire with a radius R carrying a current \vec{I} distributed homogeneously over the wire (see Fig. 2.8). The current density \vec{J} in this case is just the total current divided by the surface of a cross-section through the wire:

$$\vec{J} = \frac{\vec{I}}{\pi R^2} \quad (2.48)$$

From the symmetry of the problem we can conclude that the magnetic field only has a component pointing in the azimuthal (ϕ) direction, and that it only depends on the radius r . Ampere's law inside the wire now reduces to:

$$\int_{\text{line}} \vec{B} d\vec{l} = \mu_0 \int_{\text{surface}} \vec{J} d\vec{o} \quad (2.49)$$

$$B \cdot 2\pi r = \frac{\mu_0 I r^2}{R^2} \quad (2.50)$$

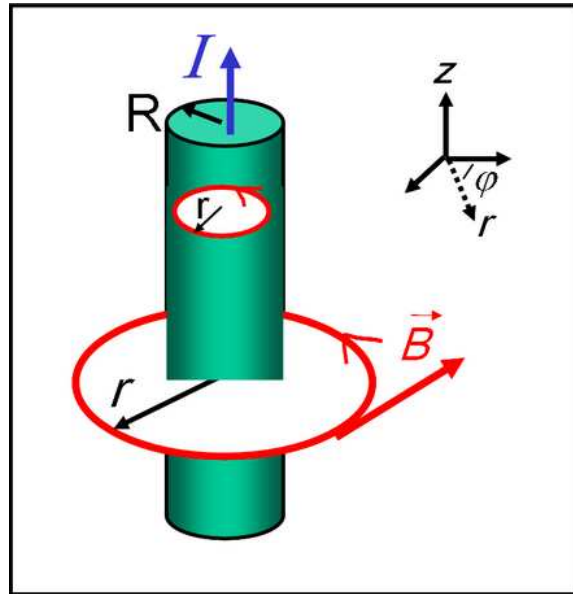

Figure 2.8: A thick wire of radius R carrying a current I that is homogeneously distributed.

so that the magnetic field in the ϕ direction as a function of r now becomes:

$$B(r < R) = \frac{\mu_0 I r}{\pi R^2} \quad (2.51)$$

Outside the wire you can show (see previous section) that the magnetic field is the same as for an infinitely thin wire. Of course if you do not *see* the cylindrical symmetry in a problem like this you can always use the law of Biot-Savart to calculate the magnetic field. The advantage is that you are always right to use this law, the disadvantage is that you will have to calculate much more complicated integrals. Remember for example how much work it was to find the magnetic field of a wire with the Biot-Savart law!

2.5.2 Plane with a homogeneous current density

As a next example of the Ampere's law we calculate the magnetic field of an infinite plane carrying a current density \vec{K} (A/m) as shown in Fig. 2.9. The plane is lying in the $y - z$ plane and the current is flowing in the y direction. Since we know that magnetic fields to be perpendicular to the currents causing them, the magnetic field cannot have a component in the y direction. From a clever symmetry argument we can also show that the component of the B-field perpendicular to the plane must also be zero. Suppose there were a component of the magnetic field in the x direction. Then rotate the whole (infinite!) plane 180° around the x axis. The current is now pointing in the opposite direction, while the x component of the B-field is unaffected. This is a clear contradiction and thus the x component of the magnetic field must be zero as well. We are only left with a magnetic field parallel to the plane in the z direction.

Now we can use Ampere's law to calculate the magnitude of the field, by constructing an imaginary rectangular path as shown in Fig. 2.9. Along this path we can again calculate the integral $\int_{\text{line}} \vec{B} d\vec{l}$. The sides of the rectangle that are perpendicular to the plane do not contribute to the line

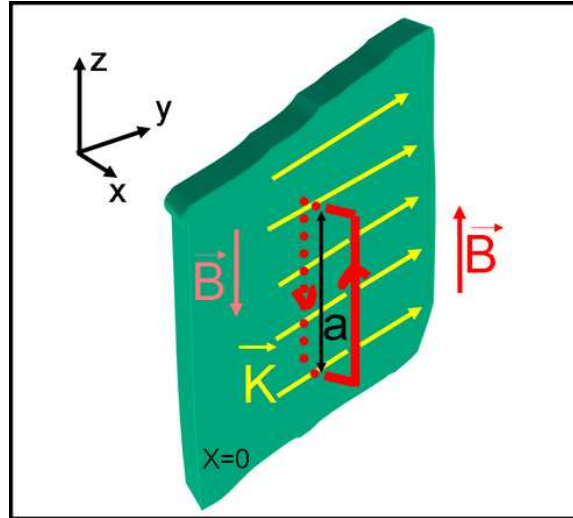

Figure 2.9: An infinitely big plane with homogeneous current density \vec{K} .

integral since we just showed that the magnetic field does not have a component perpendicular to the plane, so we are left with the two sides that are parallel to the plane. So:

$$\int_{\text{line}} \vec{B} d\vec{l} = 2aB_z \quad (2.52)$$

Ampere's law tells us that this integral should be equal to μ_0 times the enclosed current. So we can now solve the \vec{B} field:

$$2aB_z = \mu_0 K a \quad (2.53)$$

$$\Downarrow \quad (2.54)$$

$$B_z = \frac{\mu_0 K}{2} \quad (2.55)$$

So the field is homogeneous on either side of the plane. Only the sign of the magnetic field flips (try to confirm the direction yourself by using the right-hand-rule).

2.5.3 The Solenoid

An even more complicated configuration that is made simple by Ampere's law is the solenoid. A solenoid is an infinitely long cylinder of radius R over which a wire carrying a current I is wrapped around with N windings per meter (see Fig. 2.10). We can start-off with a couple of symmetry arguments to reduce some of the components of the magnetic field to zero, just as we did before for the infinite plane. First there can be no component in the ϕ direction, since it is parallel to the current. Secondly, suppose there is a radial component to the field. Then by rotating the cylinder around the x axis over 180° the current is now going in the opposite direction and the radial component of the B field is unaffected: contradiction! The radial component of the field can only be zero, so we are left with only a z component.

Let's first calculate the field *outside* the solenoid. We can take the line integral around a path

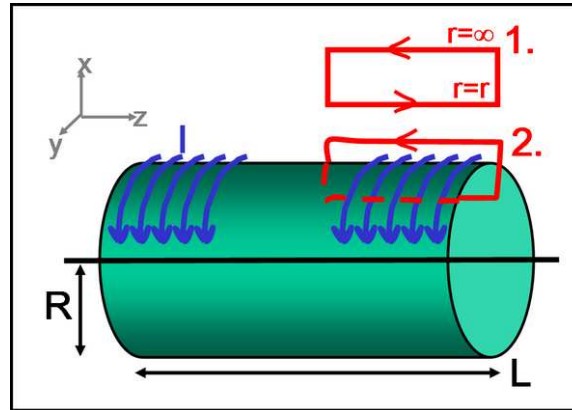

Figure 2.10: A solenoid with radius R and current I running through N windings per meter.

indicated by **1** in Fig. 2.10. There is no enclosed current so Ampere's law reduces to:

$$\int_{\text{line}} \vec{B} d\vec{l} = 0 \quad (2.56)$$

We can safely assume that the magnetic field should go to zero when the far end of the integration path goes to infinity. In that case we only get a contribution to the path integral from the line piece at $r = r$. Since the total integral needs to be zero, this can only be true if the field itself is zero. So outside a solenoid the magnetic field is zero!

The field inside we can obtain by integrating the B-field along the path indicated by **2** in Fig. 2.10. The only contribution to the integral is from the path inside the solenoid parallel to the z axis. The enclosed current is simply:

$$I_{\text{enclosed}} = aIN \quad (2.57)$$

Ampere's law is now written as:

$$\int_{\text{line}} \vec{B} d\vec{l} = \mu_0 \int_{\text{surface}} \vec{J} d\vec{\sigma} \quad (2.58)$$

$$B_z a = \mu_0 aIN \quad (2.59)$$

$$\Downarrow \quad (2.60)$$

$$B_z = \mu_0 IN \quad (2.61)$$

A surprisingly simple answer for such a complicated configuration.

2.5.4 Knowledge and Skills

The knowledge and skills you should have acquired during reading of the previous can be summarized as follows:

- You should be familiar with *line*, *surface* and *volume* currents;
- You should be able to calculate the Lorentz force on these different kinds of current densities;
- You should be able to write down and use Ampere's law to calculate magnetic fields in situations with a high degree of symmetry.

2.6 Field equations

In this section we will give an overview of the equations that give a full description of electro- and magnetostatics. In order to do so there is one more bit of mathematics you need to know.

2.6.1 Stokes' theorem

The last bit of math you need to know before we can complete the theory of electro- and magnetostatics is the theorem of Stokes. In electrostatics Gauss's law (see section 1.3) gave a relation between surface integrals of the electrical field and a volume integral of a charge density. It turns out that for the line integrations you encounter in magnetostatics a similar type of relation can be found. For any vector field the integral around a surface is equal to the curl of the vector field integrated over the surface:

$$\int_{\text{line}} \vec{A} \cdot d\vec{l} = \int_{\text{surface}} (\vec{\nabla} \times \vec{A}) d\vec{o} \quad (2.62)$$

We will not rigorously prove Stokes theorem, but we will try to give a more hand-waving argument to make it acceptable to you. Assume you have a vector field $\vec{A}(x, y, z)$ and you want to calculate the path integral of the vector field around an infinitesimal small loop in the plane $z = 0$ as shown in Fig. 2.11. The line integral $\int_{\text{line}} \vec{A} d\vec{l}$ is then split up in four parts, with a contribution from each

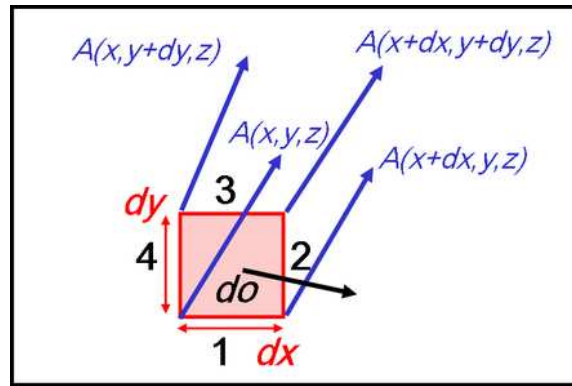

Figure 2.11: Vector field integrated along a path enclosing an infinitesimal loop in the xy plane.

of the sides of the little square. For each of the sides we must think what $d\vec{l}$ should be, especially paying attention to the plus and minus signs. Along path **1** $d\vec{l} = (dx, 0, 0)$, along path **2** we move in the positive y direction so $d\vec{l} = (0, dy, 0)$. Paths **3** and **4** are in the $-x$ and $-y$ direction, respectively, so they pick up a minus sign with respect to paths **1** and **2**. So the line integration becomes:

$$\int_{\text{line}} \vec{A} d\vec{l} = \int_x^{x+dx} A_x(x', y) dx' + \int_y^{y+dy} A_y(x, y') dy' - \quad (2.63)$$

$$\int_{x+dx}^x A_x(x', y+dy) dx' - \int_{y+dy}^y A_y(x', y+dy) dy' \quad (2.64)$$

Notice that I have left out the z index everywhere since $z = 0$ anyhow. The first component can be calculated explicitly:

$$\int_x^{x+dx} A_x(x', y) dx' = \frac{1}{2} (A_x(x, y) + A_x(x + dx, y)) dx \quad (2.65)$$

If you do this to all four terms and then collect the A_x and A_y terms together (go ahead and try) you will find that:

$$\int_{\text{line}} \vec{A} d\vec{l} = dx dy \left(\frac{\partial A_x}{\partial y} - \frac{\partial A_y}{\partial x} \right) \quad (2.66)$$

$$= (\vec{\nabla} \times \vec{A})_z d\sigma \quad (2.67)$$

$$= (\vec{\nabla} \times \vec{A}) \cdot d\vec{\sigma} \quad (2.68)$$

For a non-infinitesimal path in the $x - y$ plane we can write the *surface* integral as the sum of many infinitesimal surface integrals as shown in Fig. 2.12. Using the theorem we just derived

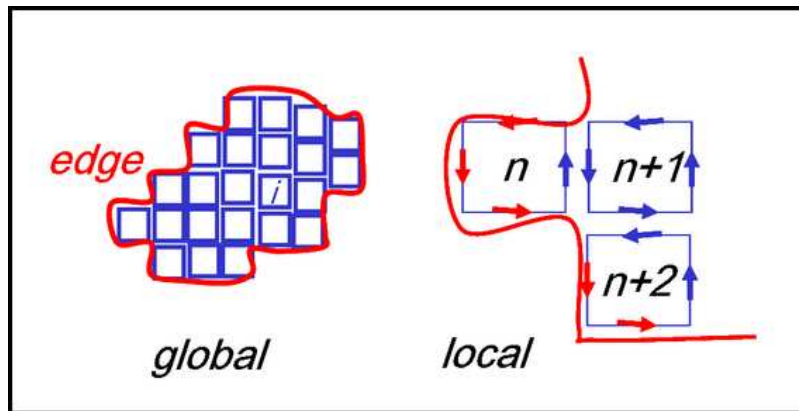

Figure 2.12: Many infinitesimal path integrations make up a big one. Notice how only the boundary integration remains.

for infinitesimal path integrals, you can see from the figure each side of the infinitesimal loop borders to another infinitesimal loop that gives exactly an opposite contribution to the path integral, except when the loop is at the border of your integration area. That is how the relation between a total surface integration and the path integral around the surface comes about. In this context it is instructive to think of the the curl of a vector as a little *whirlpool* around it: then it becomes easy to see why Stokes theorem makes sense. You have to notice that we really did not give any general proof of the theorem. We restricted ourselves to integration in the xy plane, and certainly not any surface. For a more rigorous proof please refer to any vector analysis textbook.

2.6.2 Stokes theorem: example

At this point it is worth to go through an example in which we can apply Stokes' theorem. Suppose we want to calculate the path integral over a circular path with radius R and center $x = y = 0$ for a vector field \vec{A} that is parametrized as:

$$\vec{A} = \frac{(-y, x, 0)}{\sqrt{x^2 + y^2}} \quad (2.69)$$

In Fig. 2.13a you see what the vector field looks like. So what about the line integral? The vector field is just the unit vector in the ϕ direction so:

$$\int_{\text{line}} \vec{A} \cdot d\vec{l} = \int_{\text{circle}} dl = 2\pi R \quad (2.70)$$

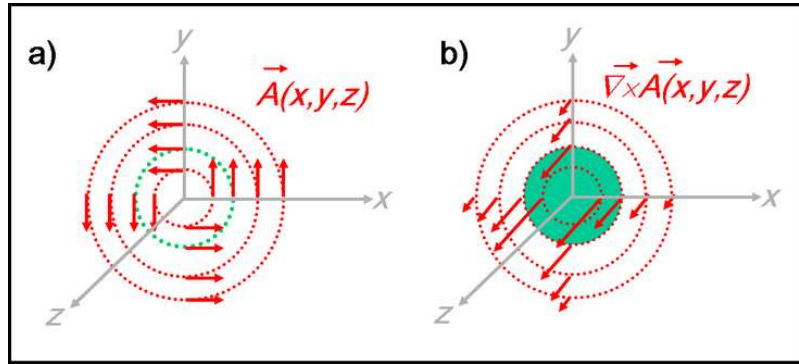

Figure 2.13: In Fig. a) you see a drawing of the vector field \vec{A} , in Fig. b) a drawing of $\vec{\nabla} \times \vec{A}$.

According to Stokes theorem we could also calculate the curl of this vector field and then do the integration over the surface spanned by the path. So first the curl of the vector field:

$$\vec{\nabla} \times \vec{A} = \begin{vmatrix} \hat{x} & \hat{y} & \hat{z} \\ \partial_x & \partial_y & \partial_z \\ A_x & A_y & A_z \end{vmatrix} = \hat{z} \left(\frac{\partial}{\partial x} \frac{x}{\sqrt{x^2 + y^2}} + \frac{\partial}{\partial y} \frac{y}{\sqrt{x^2 + y^2}} \right) \quad (2.71)$$

$$= \frac{\hat{z}}{\sqrt{x^2 + y^2}} \equiv \frac{\hat{z}}{r} \quad (2.72)$$

In Fig. 2.13b the curl of the vector field \vec{A} is drawn. Now let's calculate the surface integral of $\vec{\nabla} \times \vec{A}$.

$$\int_{disk} \vec{\nabla} \times \vec{A} = \int_{r=0}^{r=R} \int_{\phi=0}^{\phi=2\pi} \frac{1}{r} r dr d\phi = 2\pi R \quad (2.73)$$

Notice the factor r coming from the integration in cylindrical coordinates. The answer you get either way is exactly the same, though the work has been considerably more extensive when calculating the surface integral.

2.6.3 The curl of \vec{B}

We can now use Stokes theorem to find an elegant differential formulation of the law of Ampere, just as we could use Gauss law in electrostatics to go from Gauss's law in integral form to Gauss's law in differential form. Recall Ampere's law:

$$\int_{line} \vec{B} d\vec{l} = \mu_0 \int_{surface} \vec{J} \cdot d\vec{o} \quad (2.74)$$

Stokes theorem (equation 2.62) now tells us that the path integral on the left hand side of equation 2.74 can be written as the surface integral of the curl of \vec{B} . So equation 2.74 becomes:

$$\int_{surface} (\vec{\nabla} \times \vec{B}) \cdot d\vec{o} = \mu_0 \int_{surface} \vec{J} \cdot d\vec{o} \quad (2.75)$$

This can only be true for any \vec{B} if:

$$\vec{\nabla} \times \vec{B} = \mu_0 \vec{J} \quad (2.76)$$

Please realize that equation 2.76 is *equivalent* to Ampere's law in integral form (equation 2.74); there is really nothing new in this equation, except for the notation.

Now a little example. We have calculated the magnetic field for a thick wire with a current in section 2.5.1 to be:

$$\begin{cases} \vec{B} = \frac{\mu_0 I r}{2\pi R^2} \hat{\phi} = \frac{\mu_0 I}{2\pi R^2} (-y, x, 0) & r < R \\ \vec{B} = \frac{\mu_0 I}{2\pi r} \hat{\phi} & r > R \end{cases} \quad (2.77)$$

We can explicitly calculate the curl of \vec{B} inside the wire:

$$\vec{\nabla} \times \vec{B} = \begin{vmatrix} \hat{x} & \hat{y} & \hat{z} \\ \partial_x & \partial_y & \partial_z \\ -y & x & 0 \end{vmatrix} = \frac{2\mu_0 I}{2\pi R^2} \hat{z} = \mu_0 \vec{J} \quad (2.78)$$

Can you prove that outside the wire $\vec{\nabla} \times \vec{B} = 0$?

2.6.4 The divergence of \vec{B}

We have an expression for the curl of the magnetic field. What about its divergence? For electrical fields we had Gauss's law in differential form which stated that $\vec{\nabla} \cdot \vec{E} = \rho/\epsilon_0$. The divergence of the \vec{E} field at any point is equal to the charge density at that point. For the the divergence of *any* magnetic field we could get a similar expression, by taking the divergence of the law of Biot-Savart (equation 2.20), since Biot-Savart's law is true for magnetic fields caused by any current distribution. For such a proof see for example Griffiths chapter 5.3.2. However, we can actually predict what $\vec{\nabla} \cdot \vec{B}$ should be by comparing it to the same expression for the electrical field. In the equation for $\vec{\nabla} \cdot \vec{E} = \rho/\epsilon_0$ you see that on the right hand side of the equation you find the *electric* charge density. Since *magnetic* charges do not seem to exist, we can guess that:

$$\vec{\nabla} \cdot \vec{B} = 0 \quad (2.79)$$

This should be true for any magnetic field and it is indeed the answer you find by following the explicit proof in Griffiths. Let's see if it is true for the magnetic field of our 'good old' thick wire (see above). Inside the wire we have:

$$\vec{\nabla} \cdot \vec{B} = \vec{\nabla} \cdot \frac{\mu_0 I r}{2\pi R^2} \hat{\phi} \quad (2.80)$$

$$= \frac{\mu_0 I}{2\pi R^2} (-\partial_x y + \partial_y x) = 0 \quad (2.81)$$

Outside the wire:

$$\vec{\nabla} \cdot \vec{B} = \vec{\nabla} \cdot \frac{\mu_0 I}{2\pi r} \hat{\phi} \quad (2.82)$$

$$= \frac{\mu_0 I}{2\pi} \left(-\partial_x \frac{y}{r^2} + \partial_y \frac{x}{r^2} \right) = 0 \quad (2.83)$$

Notice here that we would run into serious problems if we would have chosen to calculate $\vec{\nabla} \cdot \vec{B}$ for a wire with zero thickness, due to the singularity in the \vec{B} field at $r = 0$.

Now remember that Gauss's law for electrostatics could be either written in the differential form as shown above or in integral form:

$$\int_{\text{surface}} \vec{E} d\vec{o} = \frac{1}{\epsilon_0} \int_{\text{volume}} \rho dV \quad (2.84)$$

Or in words: the integration of the \vec{E} field over a closed surface (i.e. flux) is equal to the total charge enclosed. Since we know now that $\vec{\nabla} \cdot \vec{B} = 0$, we can write for the magnetic flux through any surface with help of the law of Gauss:

$$\Phi_B = \int_{\text{surface}} \vec{B} d\vec{o} \quad (2.85)$$

$$= \int_{\text{volume}} \vec{\nabla} \cdot \vec{B} dV = 0 \quad (2.86)$$

So the magnetic flux through any closed surface is equal to zero. This is another way of stating that there exist no magnetic charges.

2.6.5 Summary: Field equations for \vec{E} and \vec{B} fields

At this point we know all there is to know about electrostatics and magnetostatics. For any stationary charge distribution we can in principle calculate the corresponding electric field and for any steady current we can calculate the resulting magnetic field (though the calculations are not always easy). In addition we know how a charged particle behaves in these fields, since we have the equation for the Lorentz force on a charged particle:

$$\vec{F}_L = q(\vec{E} + \vec{v} \times \vec{B}) \quad (2.87)$$

There are just four equations needed to calculate all electrical and magnetic fields. In integral form:

$$\int_{\text{surface}} \vec{E} \cdot d\vec{o} = \frac{1}{\epsilon_0} \int_{\text{volume}} \rho dV \quad (\text{Gauss law}) \quad (2.88)$$

$$\int_{\text{line}} \vec{E} \cdot d\vec{l} = 0 \quad (2.89)$$

$$\int_{\text{surface}} \vec{B} \cdot d\vec{o} = 0 \quad (2.90)$$

$$\int_{\text{line}} \vec{B} \cdot d\vec{l} = \mu_0 \int_{\text{surface}} \vec{J} \cdot d\vec{o} \quad (\text{Ampere's law}) \quad (2.91)$$

Using Stokes theorem and the divergence theorem - just mathematical trickery - these integral equations can be re-written as the following set of differential equations:

$$\vec{\nabla} \cdot \vec{E} = \frac{\rho}{\epsilon_0} \quad (2.92)$$

$$\vec{\nabla} \times \vec{E} = 0 \quad (2.93)$$

$$\vec{\nabla} \cdot \vec{B} = 0 \quad (2.94)$$

$$\vec{\nabla} \times \vec{B} = \mu_0 \vec{J} \quad (2.95)$$

That is all there is to know about electro- and magneto- statics; nothing more nothing less.

2.6.6 Knowledge and Skills

The knowledge and skills you should have acquired during reading of the previous can be summarized as follows:

- You should be familiar with Stokes' theorem relating line integrals to surface integrals

- Ampere's law in differential form:

$$\vec{\nabla} \times \vec{B} = \mu_0 \vec{J} \quad (2.96)$$

- The divergence of the magnetic field is zero:

$$\vec{\nabla} \cdot \vec{B} = 0 \quad (2.97)$$

- You should know the four equations describing electrostatics and magnetostatics

2.7 Magnetic fields in matter

In this section we will try to explain what happens if matter is placed inside magnetic fields.

2.7.1 Paramagnetism: electron spin

Since every electron in matter has intrinsic spin it carries a little magnetic dipole moment with a dipole moment:

$$m = \frac{q_e h}{2m_e} \quad (2.98)$$

You can imagine the electron as a spinning electric charge, or a current loop if you want (see section 2.2.6). Without a magnetic field (see Fig. 2.14a) these dipoles are randomly oriented, but if a magnetic field is applied the dipole moments - and thus the spin vectors - try to align themselves with the magnetic field. As a result of the aligned dipole moments the magnetic field is *enhanced*: enhancement of a magnetic field in matter due to an applied magnetic field we call *paramagnetism*. It seems that since every material contains electrons paramagnetism should be a universal effect

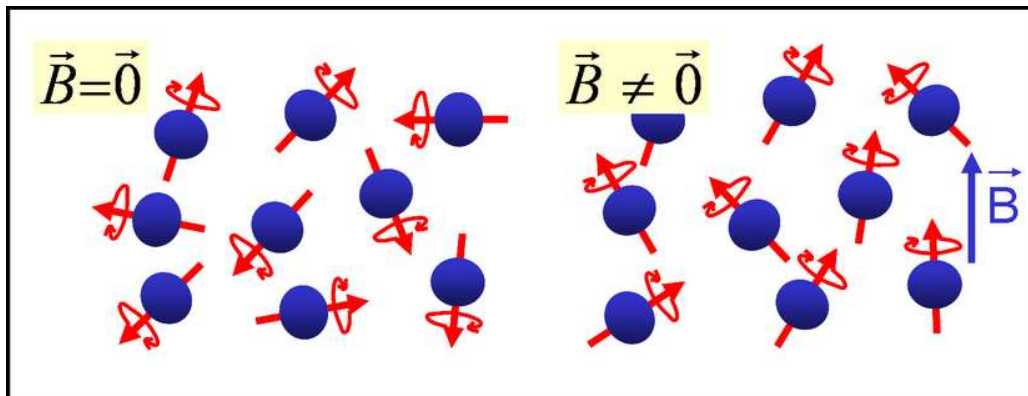

Figure 2.14: Alignment of electron spins in a magnetic field as a cause of para-magnetism.

for all substances. However the Pauli exclusion principle (quantum mechanics) does not allow electrons in the same orbit to have their spins aligned. So as a rule of thumb only substances with an odd number of electrons exhibit paramagnetism due to spin alignment, while for substances with even number of electrons the effect cancels out. Even when a substance is paramagnetic the alignment of spins is usually (room temperatures) far from complete due to thermal fluctuations. A last point to remember is that as soon as the external magnetic field disappears, the paramagnetic effect disappears, and the dipole moments are randomly distributed once more.

2.7.2 Paramagnetism: Electron orbit

Just as the electron has a magnetic moment, so does the orbiting electron around the nucleus. Again a current loop! This effect only gives a minute contribution to the paramagnetism, since it turns out to be much harder to 'turn' an entire orbit than it is to turn a spin.

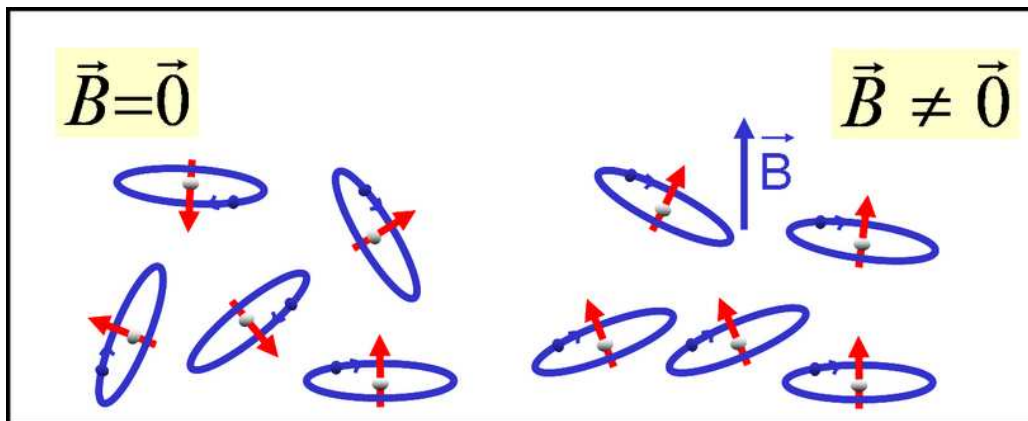

Figure 2.15: Alignment of electron orbits resulting in para-magnetism.

2.7.3 Diamagnetism

There is a second, more subtle, effect of a magnetic field on the orbit of an electron, for which we will have to look a bit deeper into the centripetal acceleration that holds an atom together. Without a magnetic field the centripetal acceleration is caused by the Coulomb attractive force alone. So:

$$\frac{1}{4\pi\epsilon_0} \frac{e^2}{R^2} = m_e \frac{v^2}{R} \quad (2.99)$$

Now suppose there is a magnetic field, that is perpendicular to the plane of orbit of the electron and opposite to the direction of the magnetic moment of the atomic orbit (situation shown to the right side of Fig. 2.16). In that case the centripetal force is sustained by both the Coulomb and the

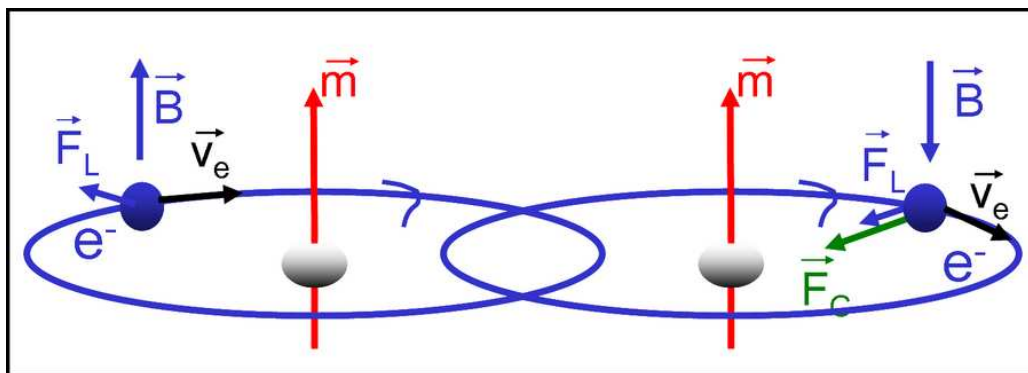

Figure 2.16: Changing velocity of the electrons in a magnetic field resulting in diamagnetism.

Lorentz forces. Equation 2.99 now becomes:

$$\frac{1}{4\pi\epsilon_0} \frac{e^2}{R^2} + ev' = m_e \frac{v'^2}{R} \quad (2.100)$$

By subtraction of the above two equation, and assuming that the change in velocity is small, we get for the change in velocity (see Griffiths section 6.1.3):

$$v - v' \approx \frac{eRB}{2m_e} \quad (2.101)$$

When a magnetic field is turned on the electron speeds up and thus the magnetic moment increases. If the magnetic moment would have been in the opposite direction as shown to the left side in Fig. 2.16, the velocity of the electron would decrease, and thus the magnetic moment would decrease.

In both cases there is a change in magnetic dipole moment that is opposite to the direction of the applied magnetic field. This effect is called diamagnetism. All substances show diamagnetism, but in general it is much weaker than paramagnetism, so in general it is only visible when paramagnetism is absent. In general this was shown to be the case for materials with even numbers of electrons. Furthermore, the calculation as shown here does not always give a reliable result, it is just made to make the argument clear. To get quantitative answers on diamagnetism a full quantum mechanically correct calculation is required.

2.7.4 Magnetization and Bound Currents

In the previous section we saw the effects of magnetic field on matter on a microscopic scale. Now we will give a macroscopic description of magnetic fields in matter. Let us first consider a cylinder of para-magnetic material that is placed inside a magnetic field (see Fig. 2.17a). The magnetic field - on average - aligns the magnetic dipoles in the material. So there is an average dipole moment per volume element, which is defined as

$$\vec{M} \equiv \frac{\text{dipole moment}}{\text{volume}} \quad (2.102)$$

We call \vec{M} the magnetization of the material. If you remember that a magnetic dipole is in fact nothing else than a little current loop you can have a look on top of the cylinder (see Fig.2.17b). You see all the current loops lying side-by-side and effectively only a current is running over the edge of our cylinder. So in case we have a uniformly magnetized object, it can be described as if there was a current running over the edge of the object. The magnetization of an object can thus be interpreted as a surface current.

We can make the above argument more quantitative by considering an example in which a slab of para-magnetic material is placed in a magnetic field (see Fig. 2.18a). We can have a look at the dipole moment for each little block in the slab by multiplying the magnetization by the volume of the little block. This should be equal to the effective current going around the block multiplied by its area (remember that $\vec{m} = \vec{I}Area$). So:

$$d|\vec{M}|Area = I_{block}Area \quad (2.103)$$

Now it can be clearly seen from the figure that neighboring blocks have sides carrying opposite currents, at least in case the magnetization is homogeneous. As a result there is an effective boundary current which happens to be exactly I_{block} . So:

$$I_{boundary} = I_{block} = |\vec{M}|d \quad (2.104)$$

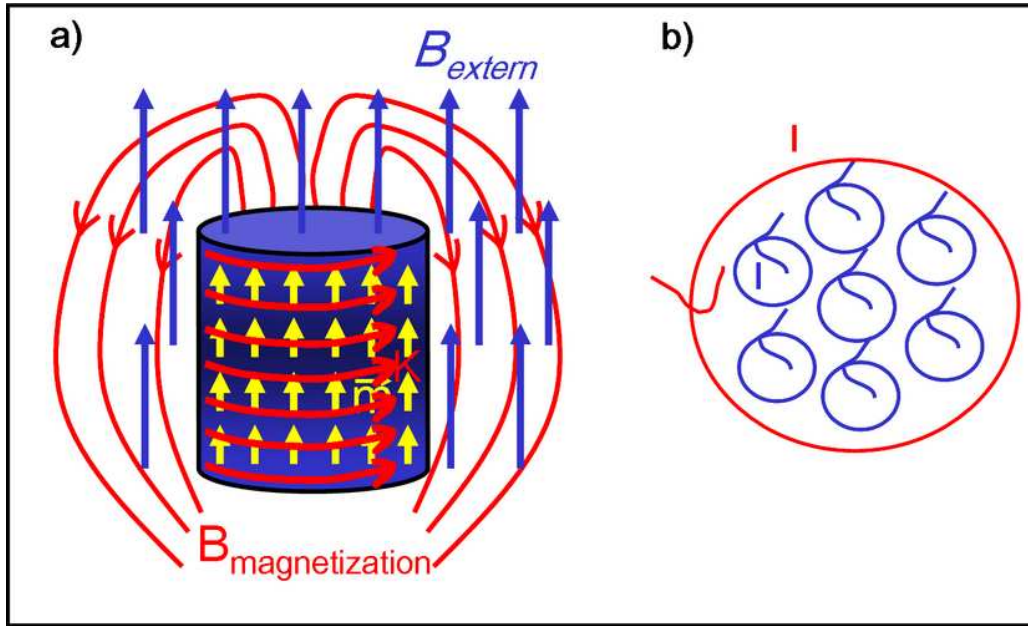

Figure 2.17: Effect of a magnetic field on a macroscopic object.

The surface current density K is just the current per unit length:

$$K = \frac{|\vec{M}|d}{d} = |\vec{M}| \quad (2.105)$$

Figure 2.18b shows the equivalent situation for our magnetized slab of material. In a more general notation our current density can now be written as the cross-product of the magnetization vector and the normal vector to the surface:

$$\vec{K}_{mag} = \vec{M} \times \hat{n} \quad (2.106)$$

Finally if the magnetization is non-homogeneous there will also be an effective volume current density (see Griffiths section 6.2), which is written as:

$$\vec{J}_{mag} = \nabla \times \vec{M} \quad (2.107)$$

The vectors \vec{K}_{mag} and \vec{J}_{mag} are what we call the bound surface and volume currents, respectively. Please notice that these are some kind of effective currents, since no real charge is moved from one place to another.

2.7.5 Linear materials

A material is called a linear material its magnetization is proportional to the magnetic field. In such cases \vec{M} is written as:

$$\vec{M} = \frac{\chi_m}{\mu_0(1 + \chi_m)} \vec{B} \quad (2.108)$$

where χ_m is called the magnetic susceptibility, which is a measured quantity for each material. Please note that \vec{B} is not just the external magnetic field, but the field including the modifications due to the magnetization (tricky):

$$\vec{B} = \vec{B}_{mag} + \vec{B}_0 \quad (2.109)$$

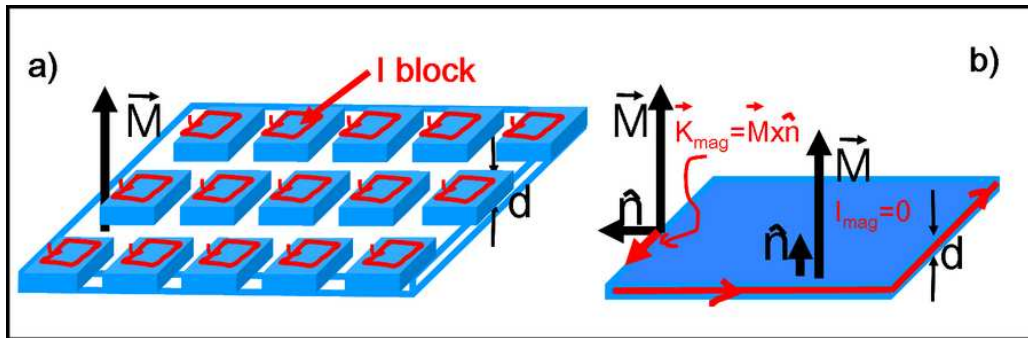

Figure 2.18: Magnetization can effectively be described by bound current densities.

where \vec{B}_{mag} is the field due to the magnetization and \vec{B}_0 is the externally supplied field.

Example: Infinite bar

Consider a long para-magnetic (linear material) cylinder inside an externally supplied magnetic field \vec{B}_0 as in Fig. 2.17. The surface bound current is written as:

$$K_{mag} = \vec{M} \times \hat{n} \quad (2.110)$$

The magnetic field due to the magnetization can be calculated with Ampere's law assuming that the cylinder is infinitely long (at this point you should be able to do the calculation yourself, so I don't do it):

$$\vec{B}_{mag} = \mu_0 |\vec{K}_{mag}| \hat{z} \quad (2.111)$$

Now we can use Eq. 2.108 to rewrite this equation in terms of its susceptibility as:

$$\vec{B}_{mag} = \chi_m \vec{B}_0 \quad (2.112)$$

So we can see that the total magnetic field inside the cylinder is modified with a factor $(1 + \chi_m)$.

Example: Infinite bar with free current

We are now considering the infinite cylinder once more, but now we are generating the external magnetic field with a wire running around the cylinder (also see section 2.5.3). Suppose we have n windings per meter and a free current I then the magnetic field due to the free current is:

$$\vec{B}_0 = nI\hat{z} = K_{free}\hat{z} \quad (2.113)$$

Now suppose we fill the interior of the cylinder with a linear magnetic material with a susceptibility χ_m , then we know from the previous example that:

$$\vec{B} = (1 + \chi_m)\vec{B}_0 = (1 + \chi_m)nI\hat{z} \quad (2.114)$$

So by inserting some material inside a magnet we have a way of amplifying (para-magnetic) or damping (dia-magnetic) the resulting field.

2.7.6 Ferromagnetism

Finally we come to the special case of ferromagnetism. In ferro-magnetic materials electron spins really love to align with each other. Whereas for the normal paramagnetic materials the alignment was far from perfect, for a ferromagnetic material the alignment can be almost 100%. Usually there are little areas - so called Weiss domains - in which the spins are aligned (see Fig. 2.19), and usually the effect of these areas cancel out giving no noticeable external magnetic field. However,

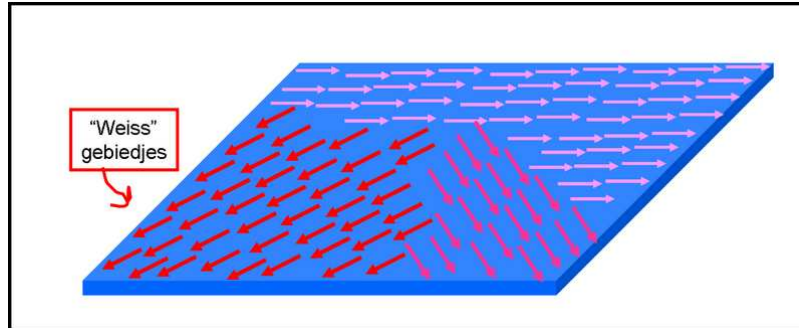

Figure 2.19: In a ferro-magnetic material there are domains where spins spontaneously align to each other. These are the so called Weiss areas.

once an external magnetic field is applied all these domains can spontaneously align themselves to the magnetic field. A small externally applied field can then result in a huge magnetic field from the material. Another interesting property of ferromagnetism is what happens when the external magnetic field is switched off. The alignment of spins might become less, but it does not disappear: you have created a permanent magnet!

If for example our solenoid from the previous example is filled with a ferromagnetic material, the resulting \vec{B} field may be 100 times larger than the externally applied field. The effect is highly non-linear as illustrated in Fig. 2.20, which shows the magnetic field as a function of the externally applied field. First the \vec{B} field grows rapidly as a function of the external field. Then at a certain

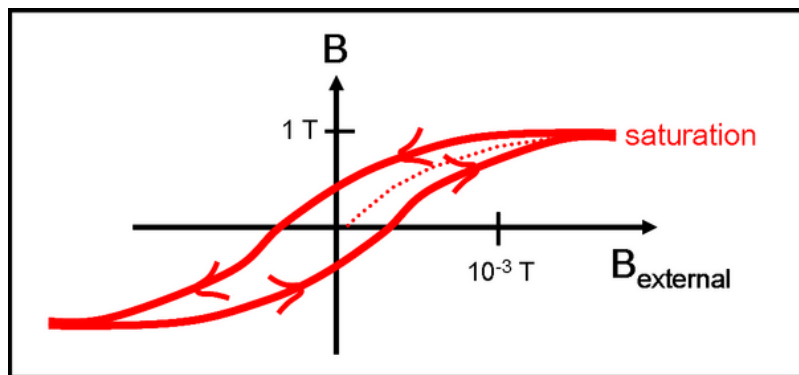

Figure 2.20: If the external magnetic field is removed from a ferro-magnetic material the magnetization does not directly disappear. This non-linear behavior is called hysteresis.

point the dipole moments of all domains are aligned and there is no further increase in \vec{B} (satura-

tion). If the external field is removed, there is still quite some magnetic field remaining due to the ferromagnetism. Only once the external field is fully reversed, the \vec{B} field finally changes sign.

2.7.7 Knowledge and Skills

The knowledge and skills you should have acquired during reading of the previous can be summarized as follows:

- In para-magnetic material the magnetization is in the same direction as the externally applied magnetic field;
- In dia-magnetic materials the magnetization is in the opposite direction as the externally applied magnetic field;
- A magnetized object can be effectively described with bound surface current density \vec{K}_{mag} and a volume current density \vec{J}_{mag} , with:

$$\vec{K}_{mag} = \vec{M} \times \hat{n} \quad (2.115)$$

$$\vec{J}_{mag} = \vec{\nabla} \times \vec{M} \quad (2.116)$$

- Linear materials are materials for which the magnetization is proportional to the magnetic field:

$$\vec{M} = \frac{\chi_m}{\mu_0(1 + \chi_m)} \vec{B} \quad (2.117)$$

where χ_m is the magnetic susceptibility of the material.

Chapter 3

Electrodynamics

3.1 Introduction

In this part we discuss the electric charge configurations and currents that are not constant in time. We start with a study of the effects of electromagnetic force acting on charge. This study allows us to understand time dependent currents in electric circuits consisting of combinations of resistors, capacitors and inductors. Our main quest is the time dependent behavior of electric and magnetic fields, leading to an elegant description in terms of the Maxwell equations.

3.2 Current and force

3.2.1 Why does current flow?

Current flows because something is pushing the charge carriers (electrons). And that something is an electric (or magnetic as we will see later) force. Let's analyze that. Consider a piece of wire made of copper with a current density \vec{J} as illustrated in Fig. 3.1. To make the electrons that constitute the

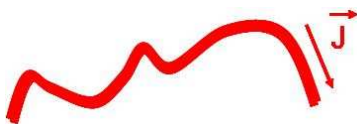

Figure 3.1: A piece of wire made of copper with a current density \vec{J} .

current a force \vec{f} is needed. The force \vec{f} is defined as a force per unit charge. For normal everyday materials and current densities, the current is proportional to the force:

$$\vec{J} = \sigma \vec{f} \tag{3.1}$$

with σ the conductivity ¹ depending on the material. Usually, in tables describing characteristics of materials, one gives the reciprocal value of this quantity, called the resistivity $\rho = 1/\sigma$.

The above expression looks reasonable at first sight, but when you think of it you may get confused about the following. When a force acts on the electrons in the wire, one would expect that the

¹Historically the symbol σ is used for conductivity, while we (and others) also use it for a surface charge density. So, don't get confused.

electrons acquire more and more speed with time. Consequently, the current would increase with time, which is not the case. Why not? Well, there appears to be a cancellation due to 'collisions' of the free electrons and the nuclei in the material. This effect, that manifests itself as a constant friction, is illustrated in Fig. 3.2. Right after the current starts an equilibrium between the accelerating force \vec{f} and the de-accelerating friction sets in.

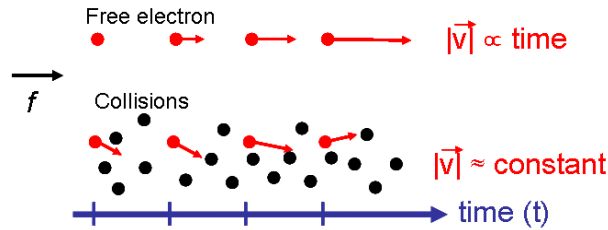

Figure 3.2: *Top: The free electron undergoes a force \vec{f} . Since it is really free its speed increases rapidly with time. Bottom: Another electron that also undergoes a force \vec{f} is constrained in a material and collides with nuclei, such that it effectively senses a frictional force that cancels \vec{f} and eventually obtains a constant velocity.*

3.2.2 Ohm's law

So far, we discussed the relation between force \vec{f} and the current density \vec{J} , without bothering about the origin of it. The origin of the force \vec{f} for our purpose is an electric field caused by any device that establishes a potential difference, such as a battery, a van der Graaff generator or a dynamo. We know that in general the electric force is given by $\vec{F} = q\vec{E}$. The force \vec{f} was defined per unit charge, thus we may write $\vec{f} = \vec{E}$. Now we consider a piece of wire with cross section A and length l . A potential difference V over the wire leads through a current I as shown in Fig. 3.3. According to

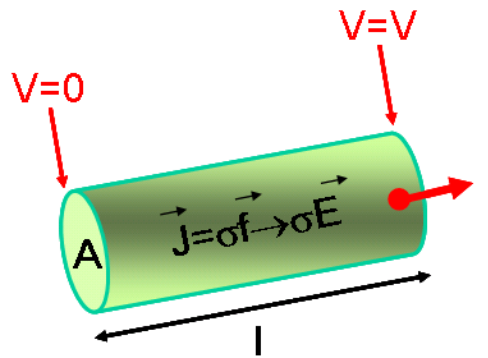

Figure 3.3: *A piece of wire with length l and cross section A . The potential difference V over its ends leads to a current \vec{I} .*

Ohm's law, V and I are related by:

$$V = IR \quad (3.2)$$

with R the resistance of the wire. This law is the subject of many physics lectures at high school. Can we derive this law? Yes, in fact its derivation is rather straightforward!

For a perfect conductor, the conductivity $\sigma = \infty$ and thus $\vec{E} = \vec{J}/\sigma = 0$. For a real, everyday, conductor the electric field inside may be zero for stationary charges, but certainly not for the situation when current flows, like in our case. In our piece of wire the electric field is given by:

$$|\vec{E}| = \frac{V}{l} \quad (3.3)$$

The current density in the wire can be written as:

$$|\vec{J}| = \sigma|\vec{f}| = \sigma|\vec{E}| = \sigma\frac{V}{l} \quad (3.4)$$

For $|\vec{J}|$ we write I/A and obtain:

$$|\vec{J}| = \frac{I}{A} = \sigma\frac{V}{l} \quad (3.5)$$

and thus:

$$V = \frac{Il}{\sigma A} \equiv IR \quad (3.6)$$

with $R \equiv \frac{l}{\sigma A}$. Hence, when we double the length l of the wire the resistance becomes twice as large. When we double the radius of the wire the resistance drops by a factor four. The conductivity of copper is about $\sigma = 6 \times 10^7 \text{ (}\Omega\text{m)}^{-1}$. A copper wire of 1 meter length and a cross section of 0.75 mm^2 has a resistance of about $R = 0.02 \text{ }\Omega$.

3.2.3 Electromotive force

Figure 3.4 shows an electric circuit with a current density \vec{J} . We know that a force \vec{f} drives the

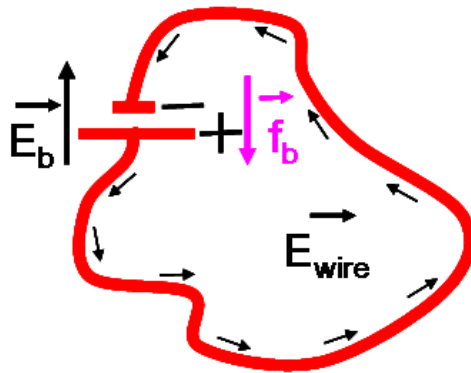

Figure 3.4: An electric circuit with current density \vec{J} . The electric field and a battery (\vec{f}_b) are also indicated.

current through the wire. In the wire this force is an electric field, an electrostatic field. The field through the wire is produced by the + and - side of a battery. We know from electrostatic theory that $\int_{\text{circuit}} \vec{E} \cdot d\vec{l} = 0$, and thus $\int_{\text{wire}} \vec{E} \cdot d\vec{l} = -\int_{\text{battery}} \vec{E} \cdot d\vec{l}$. Hence, the electric field in the battery points opposite to that in the wire. Anyway, you may ask now: if the field integrals cancel each other there is no net force, so there can't be a current. Well, we forgot the force, f_b delivered by the

battery itself, which is a chemical reaction that maintains the electric potential over the + and – side. The total force that drives a current to a circuit is thus:

$$\vec{f} = \vec{f}_b + \vec{E} \quad (3.7)$$

Note that \vec{f} is not constant in the circuit: f_b is only present in the battery and \vec{E} in the wire is different from \vec{E} in the battery.

The net effect of this force is the line integral over the circuit and is called the electromotive force:

$$\begin{aligned} EMF &= \int_{\text{circuit}} \vec{f} \cdot d\vec{l} = \int_{\text{circuit}} (\vec{f}_b + \vec{E}) \cdot d\vec{l} \\ &= \int_{\text{battery}} \vec{f}_b \cdot d\vec{l} + \int_{\text{circuit}} \vec{E} \cdot d\vec{l} \\ &= \int_{\text{battery}} \vec{f}_b \cdot d\vec{l} \end{aligned} \quad (3.8)$$

In an ideal battery there is no friction or net force on the charges and thus:

$$EMF = \int_{\text{battery}} \vec{f}_b \cdot d\vec{l} = - \int_{\text{battery}} \vec{E} \cdot d\vec{l} = V_b \left(= \int_{\text{wire}} \vec{E} \cdot d\vec{l} \right) \quad (3.9)$$

Hence, the electromotive force is just the potential (difference), V_b , of the battery.

3.2.4 Induced EMF

Consider the experiment of a circuit pulled out of an magnetic field with a speed \vec{v} as illustrated in Fig. 3.5. The movement of the circuit out of the magnetic field leads to an EMF . What is the

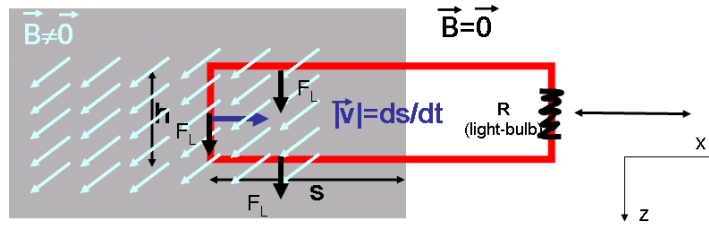

Figure 3.5: An electric circuit with a light bulb with resistance R is pulled out of a magnetic field \vec{B} . The vertical height of the circuit is h . The length of the part of the circuit that is in the magnetic field is labeled s . The Lorentz force on the (imaginary) positive charge carriers is also indicated.

source of the EMF ? It is the Lorentz force on the (moving) charges in the wire. In the figure the Lorentz force on the (imaginary) positive charge carriers is indicated, because that defines the direction of the current, while in reality the Lorentz force on the electrons is the relevant driving force. The Lorentz force in the horizontal pieces of the circuit point downward, perpendicular to the wire, as indicated. In the vertical piece of wire in the magnetic field the charge carriers that constitute a current will be pushed in the direction as indicated in the figure. The force per unit charge is $\vec{f} = \vec{v} \times \vec{B}$. For the EMF follows:

$$EMF = \int_{\text{circuit}} \vec{f} \cdot d\vec{l} = \int_0^h |\vec{f}| dl = \int_0^h |\vec{v} \times \vec{B}| dl = |\vec{v}| |\vec{B}| h \quad (3.10)$$

Note that the horizontal pieces do not contribute to the EMF . The EMF generated by the movement of the wire is called inductance, resulting in a potential difference over the light bulb of size $V_{ind} = EMF$.

For reasons that become clear in a moment we study the flux of the magnetic field through the circuit. The magnetic flux is given by:

$$\Phi_B = \int_{surface} \vec{B} \cdot d\vec{\sigma} = Bhs \quad (3.11)$$

where s is the part of the circuit that lies in the magnetic field, which depends on the time when we pull the circuit out of the field. The time derivative of the magnetic flux is given by:

$$\frac{d\Phi_B}{dt} = \frac{d(Bhs)}{dt} = Bh \frac{ds}{dt} = -Bhv = V_{ind} \quad (3.12)$$

Hence, we have found a relation between the EMF and the change of the magnetic flux:

$$EMF = -\frac{d\Phi_B}{dt} = -V_{ind} \quad (3.13)$$

This principle to create electromotive force is exploited by electric generators (dynamo's).

3.2.5 Faraday's law

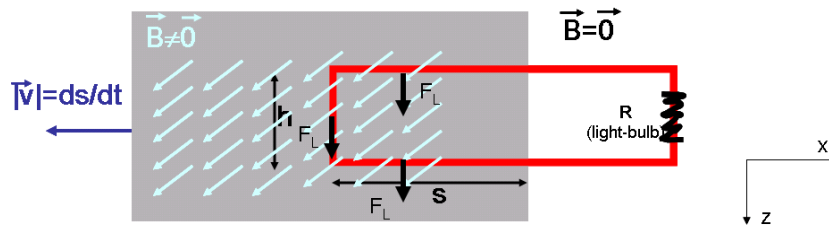

Figure 3.6: An electric circuit with a light bulb with resistance R is located in an magnetic field \vec{B} . At time $t = 0$ the magnetic field is pulled to the left.

Figure 3.6 illustrates one of the experiments Faraday conducted in 1831. In this experiment an electric circuit is first located in a magnetic field. Then, at time $t = 0$, the magnet is pulled away with a speed \vec{v} . The height of the wire loop is h and vertical part of the wire that is in the area of the magnetic field is s . An EMF leads to a current and the light bulb flashes, just like in the 'experiment' when the circuit was pulled away described in the previous section.

We ask the same question now: what is the source of the EMF ? Well, based on relativity principle, this is physics-wise exactly the same experiment as we did before. So, to calculate the EMF we transform this experiment to the previous experiment and conclude that the EMF originates from the Lorentz force.

Good, but no cigar, because it is not the answer we are looking for! Think different and forget about the relativity principle and analyze this experiment based on what we know already about electrostatic, magnetostatic and electrodynamics. We do not transform to the previous experiment: physics-wise the results should be invariant anyway! In this experiment there is no moving charge, so there is no Lorentz force as source of the EMF . We can write:

$$EMF = \int_{circuit} \vec{f} \cdot d\vec{l} = \int_{circuit} \vec{E} \cdot d\vec{l} \neq 0 \quad (3.14)$$

How can $\int_{\text{circuit}} \vec{E} \cdot d\vec{l} \neq 0$? Well, this is electrodynamics, not electrostatics! So, this time the EMF is electric in nature. When we use Stokes Law, we obtain:

$$\begin{aligned} EMF &= \int_{\text{circuit}} \vec{E} \cdot d\vec{l} \\ &= \int_{\text{surface-circuit}} (\vec{\nabla} \times \vec{E}) \cdot d\vec{o} \end{aligned} \quad (3.15)$$

From the previous section we know that

$$\begin{aligned} EMF &= -\frac{d\Phi_B}{dt} = -\frac{d}{dt} \int_{\text{surface-circuit}} \vec{B} \cdot d\vec{o} \\ &= -\int_{\text{surface-circuit}} \frac{\partial \vec{B}}{\partial t} \cdot d\vec{o} \end{aligned} \quad (3.16)$$

When we combine these results we find Faraday's Law:

$$\vec{\nabla} \times \vec{E} = -\frac{\partial \vec{B}}{\partial t} \quad (3.17)$$

Hence, a changing magnetic field induces an electric field.

In the first experiment we calculated the Lorentz force and therefore knew the direction of the current. In the second experiment it is already much harder to figure out what the direction of the current will be. And, you could get really lost when you have to predict the direction of the current in case of a time dependent magnetic field! Fortunately, there is a handy trick to do this, called Lenz's Law. It states that the:

'induced current attempts to compensate the change of magnetic flux'.

Hence, when the magnetic flux decreases (when the circuit is pulled out of the field) the induced current generates a magnetic field in the original field direction (think of the circuit as a solenoid with one winding). Use your right hand to deduce that the current flows counter clock wise in the experiments we just discussed.

3.2.6 Knowledge and skills

The knowledge and skills you should have acquired during reading of the previous can be summarized as follows:

- You can derive Ohm's Law $V = IR$ from $\vec{J} = \sigma \vec{f}$.
- You can calculate the EMF of an electric circuit.
- You understand the following relation:

$$EMF = V_{\text{induced}} = -\frac{d\Phi_B}{dt} \quad (3.18)$$

and that a changing magnetic field induces an electric field according to the relation:

$$\vec{\nabla} \times \vec{E} = -\frac{\partial \vec{B}}{\partial t} \quad (3.19)$$

- You know how to predict the induced current in an electric circuit using Lenz's Law.

3.3 Electromagnetic induction and circuits

3.3.1 Self-inductance

Figure 3.7 depicts an illustration of a current loop and its magnetic field. From Biot-Savart's Law

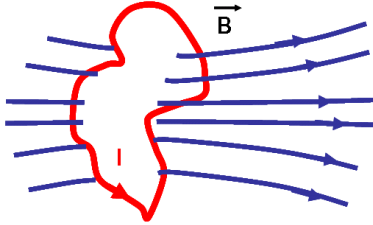

Figure 3.7: An illustration of a current loop and its magnetic field.

we know that whatever the exact shape of the current loop, its magnetic field is proportional to the current: $|\vec{B}| \propto I$. When we consider the magnetic flux through the loop, originating from its own magnetic field we can write:

$$\begin{aligned}\Phi_B &= \int_{loop} \vec{B} \cdot d\vec{\sigma} \propto I \\ &\equiv LI\end{aligned}\quad (3.20)$$

with L a factor of proportionality called self-inductance, with unit Henry, $1 \text{ H} = 1 \text{ Vs/A}$. The self-inductance only depends on the geometry and size of the loop.

When the wire loop is placed in a magnetic field, it requires an electromotive force to change its current:

$$EMF = V_{loop} = -\frac{d\Phi_B}{dt} = L\frac{dI}{dt}\quad (3.21)$$

Self-inductance of a solenoid

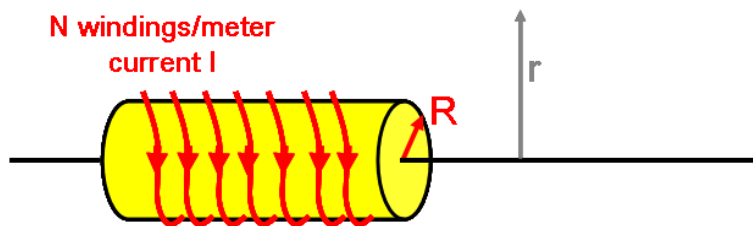

Figure 3.8: A solenoid with N windings per meter, radius R and length l .

Figure 3.8 shows a solenoid with radius R , length l and N windings per meter. To determine the self-inductance of this solenoid we calculate the flux through all windings from its own magnetic field. Using Ampère's law we know the field in the solenoid: $\vec{B} = \mu_0 NI \hat{z}$. The magnetic flux through a single winding is:

$$\Phi_B^1 = \int_{winding-surface} \vec{B} \cdot d\vec{\sigma}\quad (3.22)$$

The field points in the direction of normal of the surface, so

$$\begin{aligned}\Phi_B^1 &= \int_{\text{winding-surface}} |\vec{B}| d\sigma \\ &= \int_{\phi=0}^{2\pi} \int_{r=0}^R \mu_0 N I r dr d\phi \\ &= \mu_0 N I \pi R^2\end{aligned}\quad (3.23)$$

The number of windings of the solenoid is Nl , which leads to a total flux through the solenoid of:

$$\Phi_B = Nl\Phi_B^1 = \mu_0 N^2 I \pi R^2 l \quad (3.24)$$

As predicted, this flux is proportional to the current I . Hence, the self-inductance, L , of this solenoid is:

$$L = \Phi_B / I = \mu_0 N^2 l \pi R^2 \quad (3.25)$$

Self-inductance of a coaxial cable

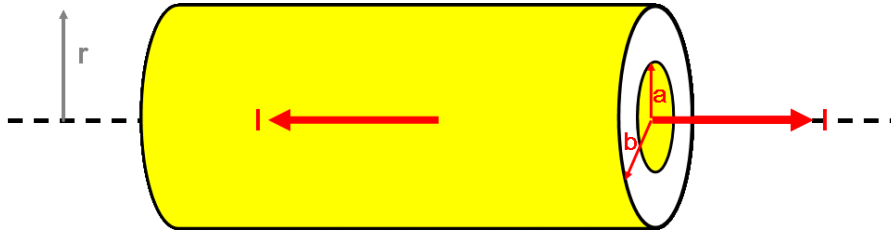

Figure 3.9: A coaxial cable with inner radius a and outer radius b and length l . In the inner and outer core, but in opposite direction, flows a current I .

Figure 3.9 shows a coaxial cable with inner radius a and outer radius b and length l . A current I flows through the inner core in one direction and runs in the opposite direction in the outer core.

Inside the cable in the region $a < r < b$, there is a magnetic field in the ϕ direction. Using Ampère's Law we determine the magnitude of this field:

$$\int_{\text{loop}} \vec{B} \cdot d\vec{l} = \int_0^{2\pi} B_\phi r d\phi = B_\phi 2\pi r = \mu_0 I \quad (3.26)$$

and thus $B_\phi = (\mu_0 I) / (2\pi r)$.

To calculate the magnetic flux in the coaxial cable we have to determine 'amount' of magnetic field that runs through the region between $a < r < b$ and length l :

$$\begin{aligned}\Phi_B &= \int_0^l dl' \int_a^b dr \frac{\mu_0 I}{2\pi r} \\ &= l \int_a^b dr \frac{\mu_0 I}{2\pi r} \\ &= l \frac{\mu_0 I}{2\pi} \ln(b/a)\end{aligned}\quad (3.27)$$

And again, the flux is proportional to I and the self-inductance becomes:

$$L = \frac{\Phi_B}{I} = l \frac{\mu_0}{2\pi} \ln(b/a) \quad (3.28)$$

3.3.2 Mutual inductance

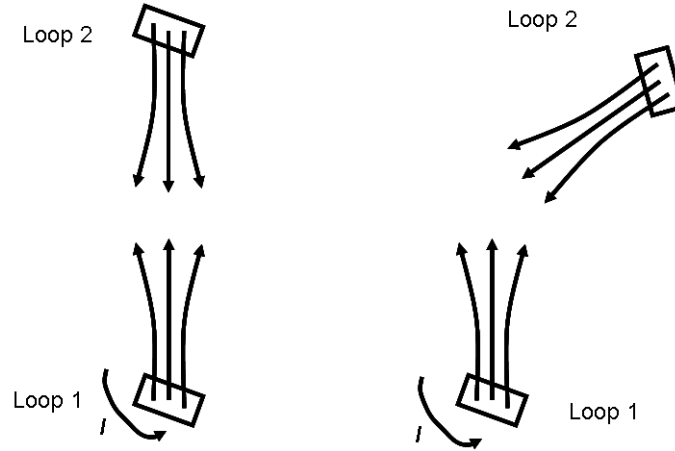

Figure 3.10: Illustration of two infinitesimal loops (1 and 2) with current I that 'sense' each other's magnetic field, indicated by the arrows. The left and right drawing depict two different orientations of the loops.

Consider two identical infinitesimal loops (we use square loops) as shown in Fig. 3.10, both with current $I = I_1 = I_2$. For the flux through loop 2 from loop 1 we can write $\Phi_2^{(1)} = MI_1 = MI$. With M a factor of proportionality, called the mutual inductance. Physically the situation is completely symmetric. Hence, for the flux through loop 1, we can write $\Phi_1^{(2)} = MI_2 = MI$, with the same factor M . If we change the orientation of the loops, the factor M changes accordingly, but the symmetry $\Phi_1^{(2)} = \Phi_2^{(1)}$ remains.

Is this relation also valid for macroscopic loops of any size and shape? We consider the infinitesimal loops again. Suppose we extend the second loop, 2a, with an additional infinitesimal loop, 2b, (with the same current) as depicted in Fig. 3.11. The extended loop $2=2a+2b$ now forms a single loop again, but just twice as large as the original. We can write:

$$\Phi_1^{(2)} = \Phi_1^{(a+b)} = \Phi_1^{(a)} + \Phi_1^{(b)} = M_a I + M_b I = M_{a+b} I \quad (3.29)$$

All the arguments before allow us to write for the individual contributions from a and b:

$$\begin{aligned} \Phi_1^{(a)} &= M_a I = \Phi_a^{(1)} \\ \Phi_1^{(b)} &= M_b I = \Phi_b^{(1)} \end{aligned}$$

and thus:

$$\Phi_2^{(1)} = \Phi_{(a+b)}^{(1)} = \Phi_a^{(1)} + \Phi_b^{(1)} = M_a I + M_b I = M_{a+b} I \quad (3.30)$$

We could extend the loop 2 again by adding another additional infinitesimal loop and would find the same relation again. In fact, we can make macroscopic loop of any size and shape of a collection of infinitesimal loops and thus we can conclude that

$$\begin{aligned} \Phi_1^{(2)} &= MI_2 \\ \Phi_2^{(1)} &= MI_1 \end{aligned} \quad (3.31)$$

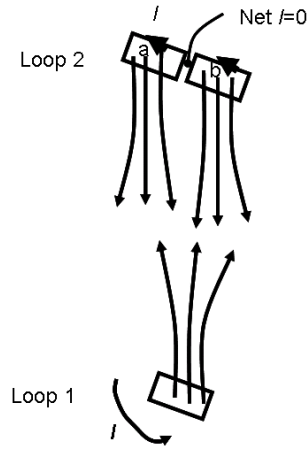

Figure 3.11: Illustration of two loops (1 and 2) with current I that 'sense' each other's magnetic field, indicated by the arrows. The second loop consists of two infinitesimal loops, a and b .

where M depends on the exact geometry of the configuration.

As an example we consider the configuration with a single current loop L , radius R_L , placed in a long solenoid S with radius R_S and N windings per meter as illustrated in Fig. 3.12. A current I

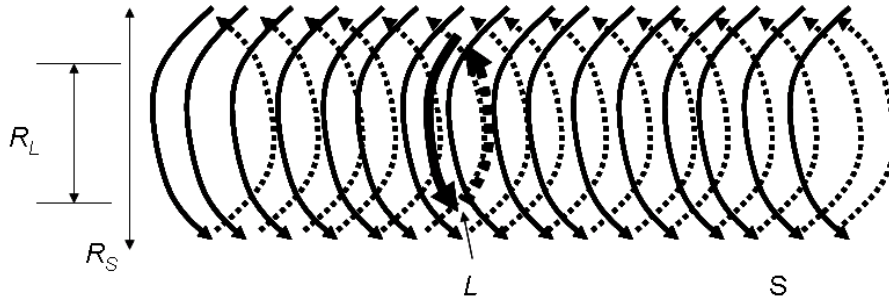

Figure 3.12: Illustration of a single loop L in a long solenoid S , both with current I .

runs through the winding(s) of L and S . What is the flux through the solenoid S from L . You could calculate the dipole field of L and determine the flux that S sees by integration. Yes, you could, but you should not. Instead, you should write down: $\Phi_L^{(S)} = MI = \Phi_S^{(L)}$. Thus, when you calculate the flux through L from S , $\Phi_L^{(S)}$, you also have $\Phi_S^{(L)}$. The solenoid generates a magnetic field of $B = B_S = \mu_0 NI$ in the axial direction. The flux through L is:

$$\Phi_L^{(S)} = B\pi R_L^2 = \mu_0\pi R_L^2 NI \quad (3.32)$$

We can read off that $M = \mu_0\pi R_L^2 N$ and thus the flux through the solenoid from the single loop is thus:

$$\Phi_S^{(L)} = MI = \mu_0\pi R_L^2 NI \quad (3.33)$$

3.3.3 Electric circuits

In the previous sections we discussed the relation between the current and the *EMF* for a resistor and for an inductor. Another object is the capacitor which was introduced in the course on electrostatics: $V_C = Q/C$. Analogous to the self-inductance L for an inductor, the capacitance C depends only on the geometry of the configuration. The *EMF* to charge a capacitor equals V_C and a relation with the current can be easily derived:

$$\frac{dV_C}{dt} = \frac{1}{C} \frac{dQ}{dt} = \frac{1}{C} I \quad (3.34)$$

Now we have three objects that we can combine to build electric circuits. Electric circuits that we consider consist of a battery that provides the potential difference V_0 leading to current through a closed circuit that consist of, or combinations of, resistor(s), capacitor(s) and inductor(s). The voltage change going around the circuit in the direction of the current flow should be zero (Kirchoff's Voltage Law). Note that we wrote voltage *change*, we can have a voltage drop or a voltage rise, implying that we should keep track of $+$ and $-$ signs once again.

For our three objects the voltage always drops when we follow the current I in the positive direction. Remember that when we cross a battery (in the direction of positive current) the voltage increases by the battery potential V_0 . We summarize these properties in Table 3.1.

Object	Potential change	relation with I
Resistor R	$-V_R$	$V_R = IR$
Inductor L	$-V_L$	$V_L = L \frac{dI}{dt}$
Capacitor C	$-V_C$	$\frac{dV_C}{dt} = \frac{1}{C} I$
Battery V_0	V_0	no resistance

Table 3.1: The voltage change over possible elements in an electric circuit when we follow the direction of the positive current.

Consider the electric circuit consisting of a battery with potential V_0 , a self-inductance L and a resistor R , shown in Fig. 3.13. At time $t = 0$ the battery is just hooked on and the current through

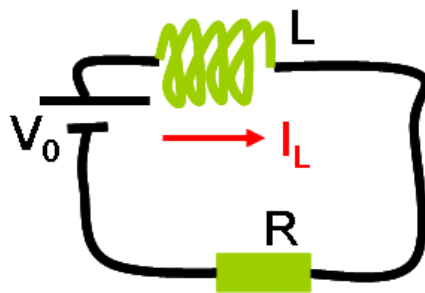

Figure 3.13: An electric circuit with a battery, resistor and a self-inductance.

the circuit is zero: $I(0) = 0$. What is the current at any time? To solve this problem, we 'walk' around starting just before the resistor and add all voltage changes: We use Table 3.1 and obtain:

$$-V_R - V_L + V_0 = 0$$

$$\begin{aligned}
 V_0 - V_L &= V_R \\
 V_0 - L \frac{dI}{dt} &= I(t)R \\
 \frac{dI}{dt} &= -\frac{R}{L}I(t) + \frac{V_0}{L}
 \end{aligned} \tag{3.35}$$

Physically we can interpret the last equation as the electromotive force $V_0 - L \frac{dI}{dt}$ of a battery and an inductor that establishes the potential $V_R = IR$ to drive a current through a resistor.

Mathematically, it is a first order differential equation with the structure $\frac{df}{dt} = af + b$. The general solution is $f(t) = ke^{at} - \frac{b}{a}$, with a , b and k constants. Returning to our LR circuit, we write:

$$I(t) = \frac{V_0}{R}(1 - e^{-(R/L)t}) \tag{3.36}$$

Figure 3.14 shows the current as function of time. At time intervals L/R , called the time constant, the current increases with fractions $1 - 1/e$.

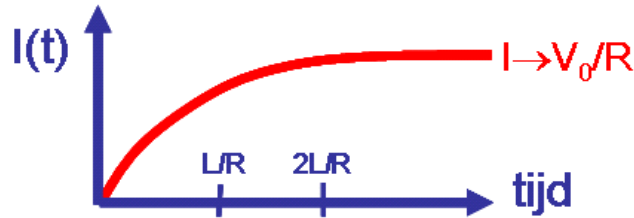

Figure 3.14: The current of an LR circuit as function of time.

Another first order circuit is shown in Fig. 3.15, which consists of a resistor, a capacitor and a battery. At time $t = 0$, the battery is just hooked on, the charge on the capacitor $Q_C(0) = 0$ (and

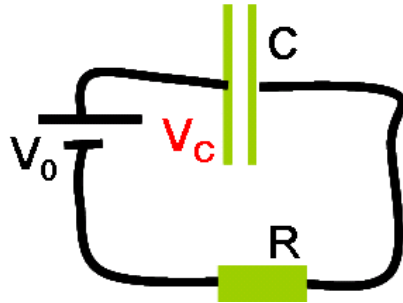

Figure 3.15: An electric circuit with a battery, resistor and a capacitor.

$V_C(0) = 0$) and the current $I(0) = 0$. What is the potential over the capacitor at any time? We 'walk' around starting just before the resistor and add all voltage changes: We use Table 3.1 and obtain:

$$\begin{aligned}
 -V_R - V_C + V_0 &= 0 \\
 V_0 - V_C &= V_R \\
 V_0 - V_C &= I(t)R \\
 V_0 - V_C &= RC \frac{dV_C}{dt}
 \end{aligned} \tag{3.37}$$

with solution:

$$V_C(t) = V_0(1 - e^{-t/(RC)}) \quad (3.38)$$

The time constant of this circuit is RC as illustrated by Fig. 3.16.

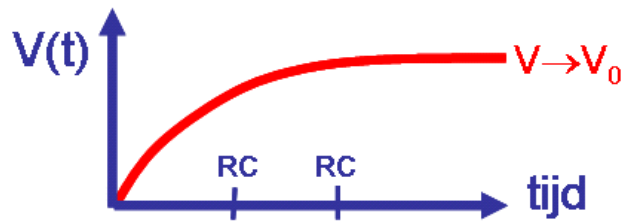

Figure 3.16: The potential difference over a capacitor in an RC circuit as function of time.

3.3.4 Energy in electric circuits

Energy dissipation in a resistor

Consider the basic circuit of a battery and a resistor, shown in Fig. 3.17 below. Each second a charge

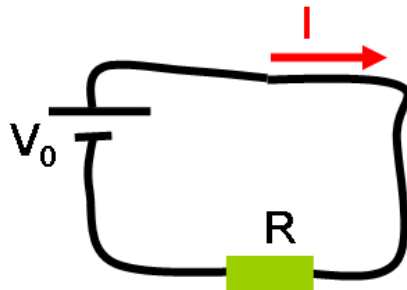

Figure 3.17: An electric circuit consisting of a battery V_0 and a resistor R .

$Q = I$ is pumped through the resistor, which requires work W . Some chemical reaction in the battery provides the necessary energy. The dissipated energy in the resistor is transformed into heat. Since the voltage change over the resistor is $V = V_0$, the energy needed to transport the charge equals $W = VQ$. The energy per second dW/dt , the power, dissipated by resistor is $P = VQ/1s = VI$ with unit Watt. Using Ohm's Law we obtain the equivalent expressions $P = I^2R$ and $P = V^2/R$.

Energy stored in a capacitor

In the course on electrostatics we have derived that the energy in a capacitor is given by $W = \frac{1}{2}CV^2$. In this section we study the energy stored in a capacitor in an electric circuit and obviously expect to find the same result. Consider an RC circuit as discussed in section 3.3.3. From the calculation in this section we conclude that the capacitor gets charged (with time constant RC). For the power required to charge the capacitor we write:

$$P = \frac{dW_C}{dt} = V_C(t)I(t) = \frac{Q_C}{C} \frac{dQ_C}{dt} \quad (3.39)$$

The total energy in a charged capacitor ($Q_C = Q$) is obtained by integration over time:

$$\begin{aligned}
 W &= \int_{t=0}^{\infty} \frac{dW}{dt} dt = \int_{t=0}^{\infty} \frac{Q_C}{C} \frac{dQ_C}{dt} dt \\
 &= \int_{t=0}^{\infty} \frac{Q_C}{C} dQ_C \\
 &= \int_{Q_C=0}^Q \frac{Q_C}{C} dQ_C = \frac{1}{2} \frac{Q^2}{C} = \frac{1}{2} CV^2
 \end{aligned} \tag{3.40}$$

which is no surprise.

An alternative expression for the energy in the electric field, also derived in the Chapter on electrostatics, is:

$$W_C = \frac{\epsilon_0}{2} \int_{\text{volume}} E^2 dv \tag{3.41}$$

Let's check this expression for a parallel plate capacitor. The distance between the plates is d and the plates have a surface area A , leading to a capacity $C = \frac{\epsilon_0 A}{d}$. In the ideal case, the electric field outside the plates is zero, while in between the plates the field is given by $|\vec{E}| = V/d$. For the energy we find

$$\begin{aligned}
 W_C &= \frac{\epsilon_0}{2} \int_{\text{volume}} \frac{V^2}{d^2} dv \\
 &= \frac{\epsilon_0 V^2}{2} Ad = \frac{\epsilon_0 A}{2d} V^2 = \frac{1}{2} CV^2
 \end{aligned} \tag{3.42}$$

as expected.

Energy stored in a self-inductance

To determine the energy stored in a self-inductance we can follow the same strategy as above. For the power required to reach a current $I_L = I$ in a self-inductance L we write:

$$P = \frac{dW_L}{dt} = I_L(t) V_{\text{induced}}(t) = I_L(t) L \frac{dI_L}{dt} \tag{3.43}$$

The total energy in the self-inductance is obtained by integration over time:

$$\begin{aligned}
 W_L &= \int_{t=0}^{\infty} \frac{dW}{dt} dt = \int_{t=0}^{\infty} I_L(t) L \frac{dI_L}{dt} dt \\
 &= \int_{I_L=0}^I I_L(t) L dI_L \\
 &= \frac{1}{2} LI^2
 \end{aligned} \tag{3.44}$$

This formula has the same structure as the expression for a capacitor. Is there also an alternative expression for energy in a self-inductance in terms of the magnetic field? Well, we could just try:

$$W_L = \frac{1}{2\mu_0} \int_{\text{volume}} B^2 dv \tag{3.45}$$

Let's check this expression for a solenoid. For a solenoid $L = \mu_0 l N^2 \pi R^2$ and thus (using equation 3.44) $W_L = \frac{\mu_0}{2} l N^2 \pi R^2 I^2$. Now we use the trial equation 3.45:

$$\begin{aligned} W_L &= \frac{1}{2\mu_0} \int_{\text{volume}} (\mu_0 N I)^2 dv \\ &= \frac{1}{2\mu_0} (\mu_0 N I)^2 l \pi R^2 \\ &= \frac{\mu_0}{2} l N^2 \pi R^2 I^2 \end{aligned} \quad (3.46)$$

which leads to the same result! Equation 3.45 is indeed the correct expression for the energy of the magnetic field. By the way, we can also use this expression for the energy to calculate the self-inductance of an object: $L = 2W_L/I^2$.

3.3.5 Knowledge and skills

The knowledge and skills you should have acquired during reading of the previous can be summarized as follows:

- You understand the meaning of self-inductance and mutual inductance.
- You can calculate the self-inductance of the solenoid and a coaxial cable.
- You can calculate the time dependent current in RC and LR circuits.
- You can calculate the energy in a self-inductance and in the magnetic field.

3.4 Maxwell equations

In this section we complete the field equations and derive the existence of electromagnetic waves: light! First we summarize the field equations, we encountered so far. Look at the structure of these

Comment	Integral
Gauss	$\int_{\text{surface}} \vec{E} \cdot d\vec{\sigma} = Q_{\text{enclosed}}/\epsilon_0 = \int_{\text{volume}} \frac{\rho}{\epsilon_0} dv$
No magnetic monopoles	$\int_{\text{surface}} \vec{B} \cdot d\vec{\sigma} = 0$
Faraday	$\int_{\text{loop}} \vec{E} \cdot d\vec{l} = -\frac{d\Phi_B}{dt}$
Ampère	$\int_{\text{loop}} \vec{B} \cdot d\vec{l} = \mu_0 I_{\text{enclosed}} = \int_{\text{surface}} \vec{J} \cdot d\vec{\sigma}$
	Differential
Gauss	$\vec{\nabla} \cdot \vec{E} = \rho/\epsilon_0$
No magnetic monopoles	$\vec{\nabla} \cdot \vec{B} = 0$
Faraday	$\vec{\nabla} \times \vec{E} = -\frac{\partial \vec{B}}{\partial t}$
Ampère	$\vec{\nabla} \times \vec{B} = \mu_0 \vec{J}$

Table 3.2: *The (incomplete) field equations based on electrostatics, magnetostatics and Faraday's Law in integral and differential form.*

equations in Table 3.2. There is an asymmetry between the electric and magnetic field, due to the fact that there exist no magnetic monopoles. In addition, there is nowhere a term $\frac{\partial \vec{E}}{\partial t}$. Did we miss something? How can we find that term, called the Maxwell term?

3.4.1 The Maxwell term from a gedanken experiment

At time $t = 0$ an empty capacitor is charged in a circuit as depicted in Fig. 3.18. Around the wire at

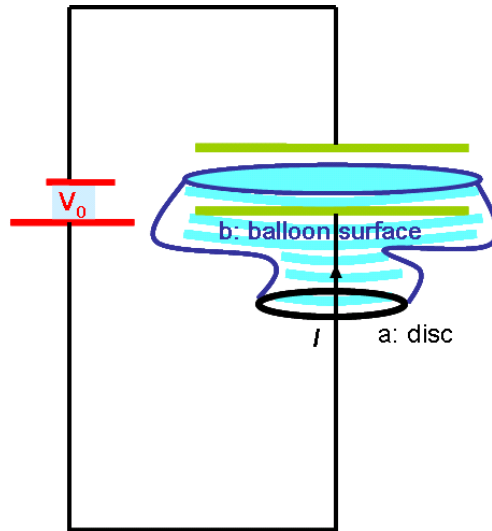

Figure 3.18: An electric circuit with a parallel plate capacitor. An Amperian loop is indicated. Also indicated are two surfaces (a and b) that are enclosed by the Amperian loop. Surface a has the 'usual' shape of a disk. Surface b has the shape of a balloon and is stretched in between the plates of the capacitor.

position a a magnetic field is generated by the current I such that Ampère's law is fulfilled:

$$\int_{loop a} \vec{B} \cdot d\vec{l} = \mu_0 I \quad (3.47)$$

In this case, the loop a spans a surface, a disk, penetrated by the the wire, thus the enclosed current is I .

Now we modify the surface a little bit and stretch it in between the capacitor plates, such that it acquires the shape of a balloon b . In fact, no wire is pointing through the surface and the the enclosed current is zero:

$$\int_{loop b} \vec{B} \cdot d\vec{l} = 0 \quad (3.48)$$

which suggests that the magnetic field has vanished in conflict with equation 3.47. Something must be wrong with Ampère's law! How can we fix that? Well, the electric field between the plates of the capacitors is $|\vec{E}| = \frac{\sigma}{\epsilon_0} = \frac{Q(t)}{A\epsilon_0}$. The time derivative is $|\frac{\partial \vec{E}}{\partial t}| = \frac{1}{A\epsilon_0} \frac{dQ}{dt} = \frac{I}{A\epsilon_0}$. A changing electric field is related to a current, which fixes Ampère's Law:

$$\int_{loop} \vec{B} \cdot d\vec{l} = \mu_0 I_{enclosed} + \mu_0 \epsilon_0 \int_{surface} \frac{\partial \vec{E}}{\partial t} \cdot d\vec{\sigma} \quad (3.49)$$

and we conclude that a changing electric field induced a magnetic field!

This calculation may look not so scientific to you or perhaps it even looks like a hat-trick. Right, but nevertheless the result correctly describes the original gedanken experiment!

3.4.2 The Maxwell term from a controlled charge explosion

Another example that yields the Maxwell term is a slowly exploding charge as illustrated in Fig. 3.19. A large collection of charge at the origin slowly explodes. In the figure, an imaginary sphere is also

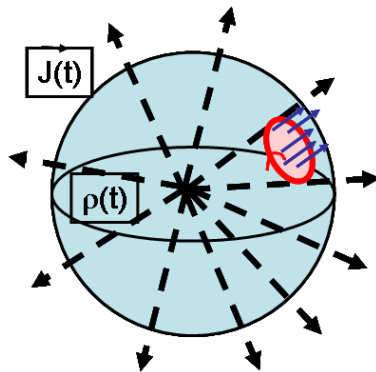

Figure 3.19: A large amount of charge at the origin slowly 'explodes'. The charge that emerges from the explosion traverses an imaginary sphere. On the surface of this sphere an infinitesimal Amperian loop is also indicated

shown. The charge that emerges from the explosion uniformly traverses the sphere. You could compare this situation with a radioactive decay. However, in radioactive decays usually, besides electrons, also photons and neutrinos are produced. Anyway, charge-wise, the explosion is comparable to radioactive decays. When we start with N_0 nuclei with charge q and lifetime τ , then the number of nuclei at a given time is $N(t) = N_0 e^{-t/\tau}$ and the total charge is $Q(t) = qN(t)$. The electric field of the charged nuclei is given by:

$$\vec{E} = \frac{1}{4\pi\epsilon_0} \frac{qN_0 e^{-t/\tau}}{r^2} \hat{r} \quad (3.50)$$

Each decay produces a charge q which leads to a 'shower of charge' that escapes: with corresponding current:

$$I = -\frac{dQ(t)}{dt} = \frac{qN_0}{\tau} e^{-t/\tau} \quad (3.51)$$

For the current density through a spherical surface we find:

$$\vec{J} = \frac{qN_0}{\tau} \frac{e^{-t/\tau}}{4\pi r^2} \hat{r} \quad (3.52)$$

where r represents the radius of the surface.

Now we investigate the integral $\int_{loop} \vec{B}(r) \cdot d\vec{l}$ of the magnetic field over a small loop on the surface of the sphere, also indicated in Fig. 3.19. The dot-product filters out the component of the magnetic field along the surface of the sphere, $B_{//}$. What is the magnitude of this component? Well, look at the symmetry of the configuration. The can not be a component of the magnetic field along the surface, and thus:

$$\int_{loop} \vec{B}(r) \cdot d\vec{l} = \int_{loop} B_{//}(r) dl = 0 \quad (3.53)$$

According to Ampère's law, this loop integral should be proportional with the enclosed current: $\mu_0 I_{enclosed} = \mu_0 \vec{J} \cdot d\vec{o}$. Is the enclosed current zero as equation 3.53 demands? No, because there is certainly charge showering through the surface enclosed by the loop. So, Ampère's Law fails again. Let's see whether the changing electric field completes the equation:

$$\begin{aligned} \int_{loop} \vec{B} \cdot d\vec{l} &= \mu_0 I_{enclosed} + \mu_0 \epsilon_0 \int_{surface} \frac{\partial \vec{E}}{\partial t} \cdot d\vec{o} \\ &= \mu_0 \int_{surface} \vec{J} \cdot d\vec{o} + \mu_0 \epsilon_0 \int_{surface} \frac{\partial \vec{E}}{\partial t} \cdot d\vec{o} \end{aligned} \quad (3.54)$$

Now we substitute the expressions we derived for the current density (equation 3.52) and the electric field (equation 3.50) and obtain:

$$\begin{aligned} \int_{loop} \vec{B} \cdot d\vec{l} &= \mu_0 \int_{surface} N_0 \frac{Q}{\tau} \frac{e^{-t/\tau}}{4\pi r^2} d\omega + \mu_0 \epsilon_0 \int_{surface} \frac{N_0 Q}{4\pi \epsilon_0 r^2} \frac{\partial e^{-t/\tau}}{\partial t} d\omega \\ &= \mu_0 \int_{surface} N_0 \frac{Q}{\tau} \frac{e^{-t/\tau}}{4\pi r^2} d\omega - \mu_0 \int_{surface} N_0 \frac{Q}{\tau} \frac{e^{-t/\tau}}{4\pi r^2} d\omega \\ &= 0 \end{aligned} \quad (3.55)$$

So, the Maxwell term $\mu_0 \epsilon_0 \int_{surface} \frac{\partial \vec{E}}{\partial t} \cdot d\vec{o}$, saves the day again!

3.4.3 Continuity equation

In the previous section we used the fact that charge is conserved. A current through a (closed) surface was the result of a changing charge in the enclosed volume:

$$\begin{aligned} I_{surface} &= -\frac{dQ_{volume}}{dt} \\ \int_{surface} \vec{J} \cdot d\vec{o} &= -\frac{d}{dt} \int_{volume} \rho dv \\ \int_{surface} \vec{J} \cdot d\vec{o} + \frac{d}{dt} \int_{volume} \rho dv &= 0 \end{aligned} \quad (3.56)$$

Using Gauss's rule we can write:

$$\int_{volume} \vec{\nabla} \cdot \vec{J} dv + \int_{volume} \frac{d\rho}{dt} dv = 0 \quad (3.57)$$

and thus:

$$\vec{\nabla} \cdot \vec{J} + \frac{d\rho}{dt} = 0 \quad (3.58)$$

This expression is known as the continuity equation.

Is this consistent with our renewed Ampère's Law? We start with:

$$\int_{loop} \vec{B} \cdot d\vec{l} = \mu_0 \int_{surface} \vec{J} \cdot d\vec{o} + \mu_0 \epsilon_0 \int_{surface} \frac{\partial \vec{E}}{\partial t} \cdot d\vec{o} \quad (3.59)$$

and use Stokes Law to write:

$$\int_{surface} \vec{\nabla} \times \vec{B} \cdot d\vec{o} = \mu_0 \int_{surface} \vec{J} \cdot d\vec{o} + \mu_0 \epsilon_0 \int_{surface} \frac{\partial \vec{E}}{\partial t} \cdot d\vec{o} \quad (3.60)$$

Note that the surface is arbitrary, thus the integrands must be equal:

$$\vec{\nabla} \times \vec{B} = \mu_0 \vec{J} + \mu_0 \epsilon_0 \frac{\partial \vec{E}}{\partial t} \quad (3.61)$$

(which by the way is the renewed Ampère's Law in differential form!) Now take the divergence of this equation and realize that the divergence of a rotation is zero by construction:

$$\vec{\nabla} \cdot (\vec{\nabla} \times \vec{B}) = 0 = \mu_0 \vec{\nabla} \cdot \vec{J} + \mu_0 \epsilon_0 \vec{\nabla} \cdot \frac{\partial \vec{E}}{\partial t} \quad (3.62)$$

or equivalently

$$\vec{\nabla} \cdot (\vec{\nabla} \times \vec{B}) = 0 = \mu_0 \vec{\nabla} \cdot \vec{J} + \mu_0 \frac{\partial \rho}{\partial t} \quad (3.63)$$

from which we can read off the continuity equation. As a matter of fact we can conclude that Ampère's Law extended with Maxwell's term leads to charge conservation.

3.4.4 The complete set of Maxwell equations

The time has come to write down the complete set of field equations which we derived during our tour through electrostatics, magnetostatics and electrodynamics leading to Faraday's Law and the Maxwell term. The equations are known as the Maxwell Equations and are listed in table 3.3. The

Comment	Integral
Gauss	$\int_{surface} \vec{E} \cdot d\vec{o} = Q_{enclosed} / \epsilon_0 = \int_{volume} \frac{\rho}{\epsilon_0} dv$
No magnetic monopoles	$\int_{surface} \vec{B} \cdot d\vec{o} = 0$
Faraday	$\int_{loop} \vec{E} \cdot d\vec{l} = -\frac{d\Phi_B}{dt}$
Ampère+Maxwell term	$\int_{loop} \vec{B} \cdot d\vec{l} = \mu_0 I_{enclosed} + \mu_0 \epsilon_0 \int_{surface} \frac{\partial \vec{E}}{\partial t} \cdot d\vec{o}$
	Differential
Gauss	$\vec{\nabla} \cdot \vec{E} = \rho / \epsilon_0$
No magnetic monopoles	$\vec{\nabla} \cdot \vec{B} = 0$
Faraday	$\vec{\nabla} \times \vec{E} = -\frac{\partial \vec{B}}{\partial t}$
Ampère+Maxwell term	$\vec{\nabla} \times \vec{B} = \mu_0 \vec{J} + \mu_0 \epsilon_0 \frac{\partial \vec{E}}{\partial t}$

Table 3.3: *The complete set of field equations based on electrostatics, magnetostatics and electrodynamics, called the Maxwell Equations, in integral and differential form.*

physical behavior of electric and magnetic field are described by these equations. In the following section we use the Maxwell Equations to derive the existence of electromagnetic waves of which light is a specific example.

3.4.5 Electromagnetic waves

The Maxwell equations, based on empirical studies, can now be used to further investigate the physics of the electric and magnetic field. In this section we study the fields in free space, which requires some mathematics, but the result will be worth it.

In vacuum, away from electric charges and currents the Maxwell Equations (in differential form) simplify to:

$$\begin{aligned}
 (a) \quad & \vec{\nabla} \cdot \vec{E} = 0 \\
 (b) \quad & \vec{\nabla} \times \vec{E} = -\frac{\partial \vec{B}}{\partial t} \\
 (c) \quad & \vec{\nabla} \cdot \vec{B} = 0 \\
 (d) \quad & \vec{\nabla} \times \vec{B} = \mu_0 \epsilon_0 \frac{\partial \vec{E}}{\partial t}
 \end{aligned} \tag{3.64}$$

Now take the rotation of 3.64*b* and write:

$$\vec{\nabla} \times \vec{\nabla} \times \vec{E} = -\vec{\nabla} \times \frac{\partial \vec{B}}{\partial t} \tag{3.65}$$

First, we concentrate on the left hand side. Using basic calculus we obtain:

$$\vec{\nabla} \times \vec{\nabla} \times \vec{E} = \vec{\nabla}(\vec{\nabla} \cdot \vec{E}) - \vec{\nabla}^2 \vec{E} \tag{3.66}$$

Remember that we are in vacuum and use equation 3.64*a* to write:

$$\vec{\nabla} \times \vec{\nabla} \times \vec{E} = -\vec{\nabla}^2 \vec{E} \tag{3.67}$$

Now, we proceed with the right hand side:

$$-\vec{\nabla} \times \frac{\partial \vec{B}}{\partial t} = -\frac{\partial \vec{\nabla} \times \vec{B}}{\partial t} \tag{3.68}$$

and use 3.64*d* to write:

$$-\vec{\nabla} \times \frac{\partial \vec{B}}{\partial t} = -\mu_0 \epsilon_0 \frac{\partial^2 \vec{E}}{\partial t^2} \tag{3.69}$$

When the results are combined we obtain:

$$\vec{\nabla}^2 \vec{E} = \mu_0 \epsilon_0 \frac{\partial^2 \vec{E}}{\partial t^2} \tag{3.70}$$

Starting with the rotation of 3.64*d* you find a similar relation for the magnetic field:

$$\vec{\nabla}^2 \vec{B} = \mu_0 \epsilon_0 \frac{\partial^2 \vec{B}}{\partial t^2} \tag{3.71}$$

Fine, so what? Well, remember the theory of waves. The classical wave equation for a wave in the z direction with speed v is:

$$\frac{\partial^2 \psi}{\partial t^2} = v^2 \frac{\partial^2 \psi}{\partial z^2} \tag{3.72}$$

with typical solution $A \cos(kz - \omega t)$ where $\omega^2 = k^2 v^2$. Hence, the equations 3.70 and 3.71 imply the existence of electromagnetic waves with speed $v = \sqrt{\frac{1}{\mu_0 \epsilon_0}} = c$, the speed of light!

Monochromatic waves in one dimension

In this section we study a typical solution of the electromagnetic wave equation. To simplify the math, we assume:

- The electric and magnetic field only depend on z and t ;
- We stay in the vacuum which is infinitely large.

This leads to the following wave equations:

$$\begin{aligned}\frac{\partial^2 \vec{E}}{\partial t^2} &= c^2 \frac{\partial^2 \vec{E}}{\partial z^2} \\ \frac{\partial^2 \vec{B}}{\partial t^2} &= c^2 \frac{\partial^2 \vec{B}}{\partial z^2}\end{aligned}$$

with solutions of the form:

$$\begin{aligned}\vec{E} &= \vec{E}^0 \cos(kz - \omega t) \\ \vec{B} &= \vec{B}^0 \cos(kz - \omega t)\end{aligned}\tag{3.73}$$

with $\omega = kc$. The constants \vec{E}^0 and \vec{B}^0 can be determined by applying Maxwell Equations in vacuum (again):

- $\vec{\nabla} \cdot \vec{E} = 0 = -E_z^0 k \sin(kz - \omega t)$ implies that $E_z^0 = 0$.
- $\vec{\nabla} \cdot \vec{B} = 0 = -B_z^0 k \sin(kz - \omega t)$ implies that $B_z^0 = 0$.
- $\vec{\nabla} \times \vec{B} = \frac{1}{c^2} \frac{\partial \vec{E}}{\partial t}$ leads to:

$$\begin{aligned}+cB_y^0 &= E_x^0 \\ -cB_x^0 &= E_y^0\end{aligned}\tag{3.74}$$

which can be written as:

$$\vec{B}^0 = \frac{1}{c} \hat{z} \times \vec{E}^0\tag{3.75}$$

The equation $\vec{\nabla} \times \vec{E} = -\frac{\partial \vec{B}}{\partial t}$ implies the same and adds no information.

We summarize our findings by saying that the Maxwell Equations have solutions that can be interpreted as electromagnetic waves with speed c , the speed of light. These waves are transverse: the electric and magnetic fields have no components in the direction of propagation ($E_z = B_z = 0$). In addition the fields are also mutual transverse and in phase. Figure 3.20 shows an illustration of an electromagnetic wave.

3.4.6 Knowledge and skills

The knowledge and skills you should have acquired during reading of the previous can be summarized as follows:

- You understand the problem in Ampère's Law.

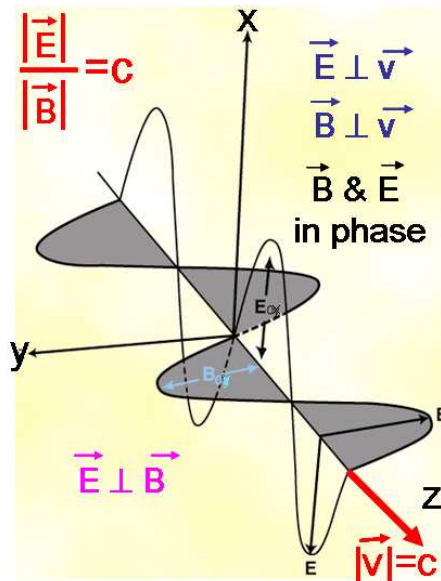

Figure 3.20: A schematic view of an electromagnetic wave.

- You can fix Ampère's Law.
- You can write down the Maxwell Equations.
- You can derive the continuity equation from these equations.
- From the Maxwell Equations in vacuum you can prove the existence of light and its properties.