

Higgs en de Kosmos



Niels Tuning (Nikhef) Hoorn, 15 april 2014

De Higgs – Waar gaat het over?

NRC HANDELSBLAD

Woensdag 4 juli 2012 Jaargang 42 no.233 Algemeen Handelsblad (1828) en Nieuwe Rotterdamse Courant (1844) Prijs € 2,-

Kairo is synoniem met seksueel geweld
buitenland 10

Pininfarina gaf Ferrari een gezicht
het grote verhaal 12-13

Afstudeerfilms: lelijke kinderen, dolende zielen
film 18-19

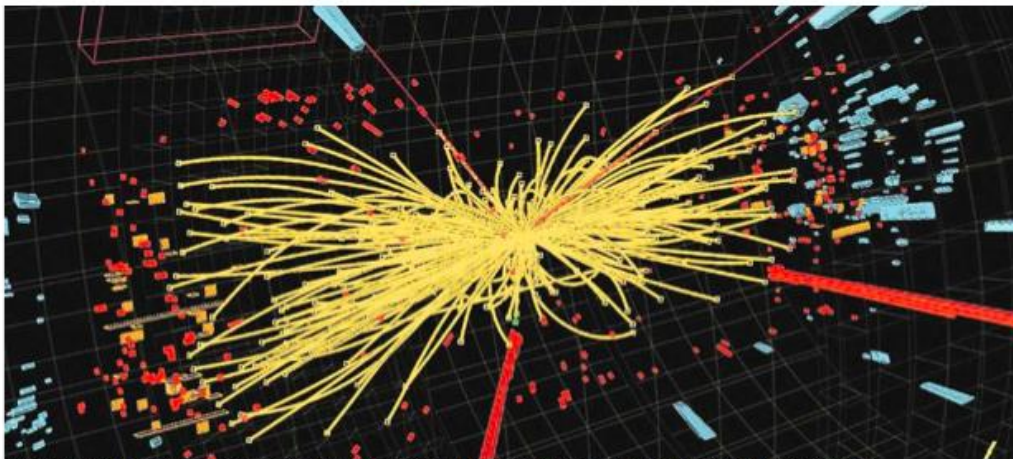

Grafische weergave van de sporen van een proton-protonbotsing in een van de deeltjesdetectoren van CERN, het deeltjesversnellerinstituut bij Genève. Foto AFP / CERN

Historische stap in het onderzoek naar de bouwstenen waaruit heelal is opgebouwd

Higgsdeeltje 'vrijwel zeker' ontdekt

Door BRUNO VAN WAYENBURG
AMSTERDAM. Na twee uur spanningrekende praatjes komt CERN-directeur Rolf Heuer samenvoegen met de mededeling: „We hebben een ontdekking, de waarneming van een nieuw deeltje, met de eigenschappen van een Higgs-boson“.

Het Higgsdeeltje dus, het enige deeltje in het standaardmodel van de natuurkunde waarvan het bestaan wel voorspeld was maar nog niet aangetoond.

Het is het deeltje dat andere deeltjes hun massa geeft. Het is groot nieuws: de mededeling leidt tot een ontleding in de zaal bij het CERN, het deeltjesversnellerinstituut bij Genève. Het publiek van vooral natuurkundigen klappt en joelt.

Aanvankelijk aarzeland applaudissen ook de onderzoekers en pers die samengekomen zijn in Nikhef, het instituut voor deeltjesfysica in Amsterdam.

Het lijkt er nu toch echt op dat ze, zij het virtueel, aanwezig zijn bij een historische aankondiging. Uit presentaties van Joe Incandela van de CMS-deeltjesdetector en van Gianotti van de ATLAS-detector, blijkt dat er maar een hele kleine kans op toeval is: minder dan 1 op de 3,5 miljoen. „Er is absoluut een nieuw deeltje ontdekt, dat valt niet meer te ontkennen“, zegt ook Stan Bentvelsen, projectleider van de Nederlandse inbreng in het ATLAS-experiment, waarbij 45 onderzoekers betrokken zijn.

Om het Higgsdeeltje aan te tonen,

moet je nieuwe deeltjes maken. Dat is peperduur, maar eenvoudig. Je laat in een deeltjesversneller deeltjes met strijvel de lichteheid met elkaar botsen. Hoe harder de botsing, hoe meer energie er wordt omgezet in nieuwe deeltjes. Zoals het Higgs-boson, dat in de jaren zestig voorspeld werd door zes theoretisch natuurkundigen. Het werd naar een van hen genoemd, Peter Higgs.

De Higgs is nodig om te verklaren hoe het komt dat alles massa heeft: doordat deeltjes worden afgeremd door het zogeheten Higgs-veld. Zo alomtegenwoordig als het uitgesproken Higgs is, zo ongripbaar is het als deeltje.

Zo gauw het ontstaat uit de enorme energie die vrijkomt bij een botsing, zo snel valt het ook weer uit el-

kaar in verschillende elementaire deeltjes. Alleen die brokstukken zijn, meteen na een botsing, goed te zien in de detectoren.

Maar veel vaker ontstaat er bij een botsing geen Higgs, maar een mix van al bekende deeltjes. Onderscheid maken tussen 'Higgs- en niet-Higgs-botsingen' is een kwestie van netjes meten en turven en zware statistiek.

Daarover gaat het allemaal, in de presentaties van Gianotti en Incandela.

In het deeltjesjagen gaat het om de signa-waarde: een statistische maat voor de kans dat je gevonden botsingen, ook al lijken ze op een nieuw deeltje, toch een toevallige uitschieter zijn. De afspraak is dat je een deeltje pas mag claimen bij een signa van 5: de kans dat het om een toevallige

uitschieter zou gaan is dan 1 op de 3,5 miljoen. Inmiddels eindigt met een tergenle 4,9, net gren 5. Maar Gianotti komt na eindeloze details uit op 5,0.

„Nu moeten we onderzoeken of het ook de Higgs is“, zegt Bentvelsen. Daar lijkt het wel op. „Al vervalt het wel iets vaker in twee fotonen dan je zou verwachten.“

„X zijn, Higgs niet het hun de-lijk eens een keer met overeenkomsten met het standaardmodel, is dus het devies. „Dit is pas het begin“, concludeert ook Gianotti.

Woensdag 4 juli 2012

Waarom is dit belangrijk?

De Higgs – Waar gaat het over?

Nobelpriset 2013 The Nobel Prize 2013

The Nobel Prize in Physics 2013



François Englert
Université Libre de Bruxelles, Belgium



Peter W. Higgs
University of Edinburgh, UK

"För den teoretiska upptäckten av en mekanism som bidrar till förståelsen av massans ursprung hos subatomära partiklar, och som nyligen, genom upptäckten av den förutsagda fundamentala partikeln, bekräftats av ATLAS- och CMS-experimenten vid CERN:s accelerator LHC."

"For the theoretical discovery of a mechanism that contributes to our understanding of the origin of mass of subatomic particles, and which recently was confirmed through the discovery of the fundamental particle, by the ATLAS and CMS experiments at CERN's Large Hadron Collider."

© Kungl. Vetensk.

Dinsdag 8 oktober 2013

"for the theoretical discovery of a mechanism that contributes to our understanding of the origin of mass of subatomic particles..."



Waarom is dit belangrijk?

De Higgs – Waar gaat het over?

Nobelpriset 2013 The Nobel Prize 2013

The Nobel Prize in Physics 2013



François Englert
Université Libre de Bruxelles, Belgium



Peter W. Higgs
University of Edinburgh, UK

"För den teoretiska upptäckten av en mekanism som bidrar till förståelsen av massans ursprung hos subatomära partiklar, och som nyligen, genom upptäckten av den förutsagda fundamentala partikeln, bekräftats av ATLAS- och CMS-experimenten vid CERN:s accelerator LHC."

"For the theoretical discovery of a mechanism that contributes to our understanding of the origin of mass of subatomic particles, and which recently was confirmed through the discovery of the predicted fundamental particle, by the ATLAS and CMS experiments at CERN's Large Hadron Collider."

© Kungl. Vetensk.

Dinsdag 8 oktober 2013

"for the theoretical discovery of a mechanism that contributes to our understanding of the origin of mass of subatomic particles..."

"... and which recently was confirmed through the discovery of the predicted fundamental particle, by the ATLAS and CMS experiments at CERN's Large Hadron Collider"



Waarom is dit belangrijk?

"Er zijn onzichtbare golven om ons heen met stemmen en beelden"

" Er is een Higgs veld in het vacuum dat alle deeltjes massa geeft"

antenne



radio

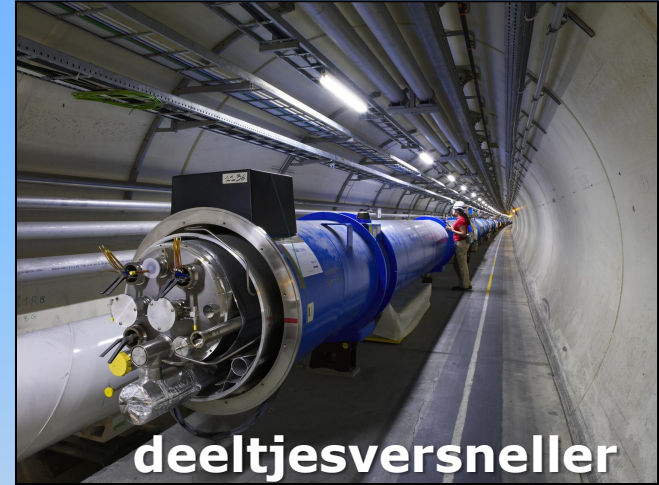

deeltjesversneller

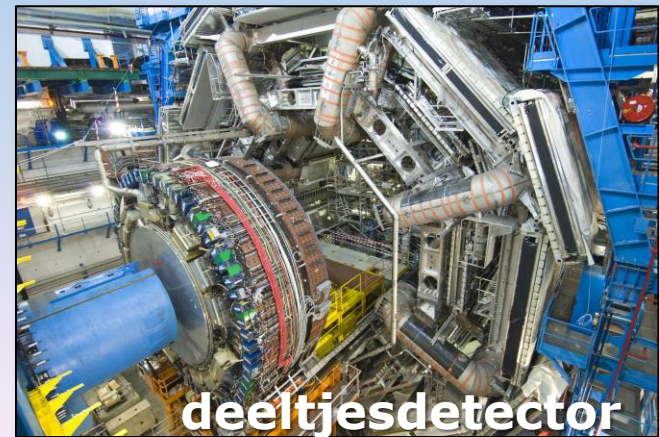

deeltjesdetector

Zoektocht naar de elementaire bouwstenen van de Natuur



Deeltjesfysica

Bestudeert de natuur op afstanden $< 10^{-15}$ m

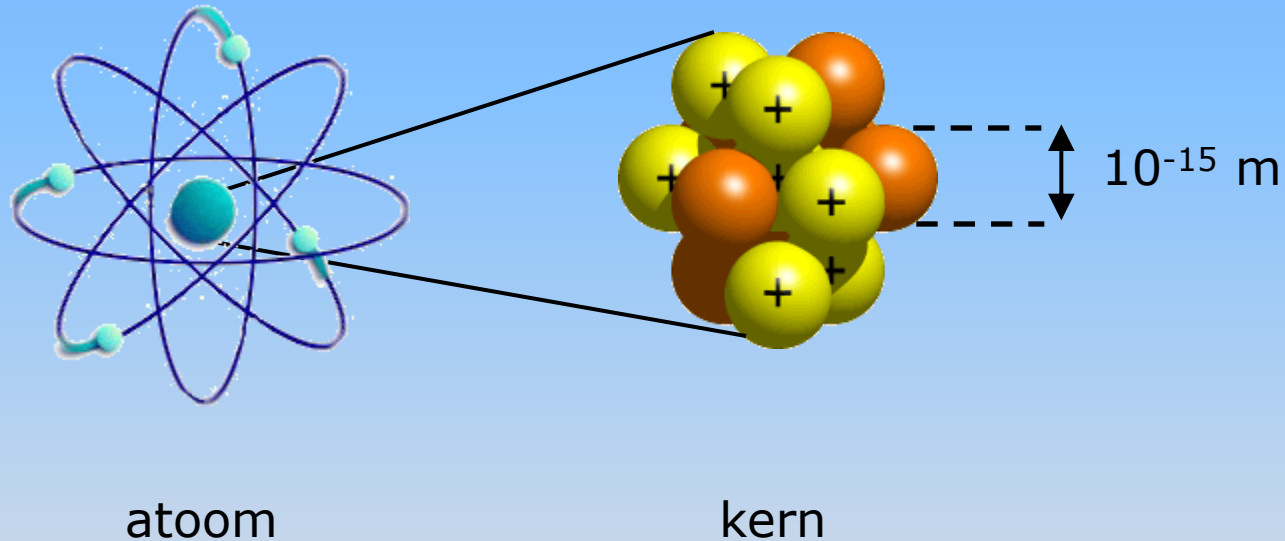

Quantum theorie beschrijft alle metingen tot 10^{-18} m

(Ter vergelijking: 10^{+18} m = 100 lichtjaar)

Machten van tien ...

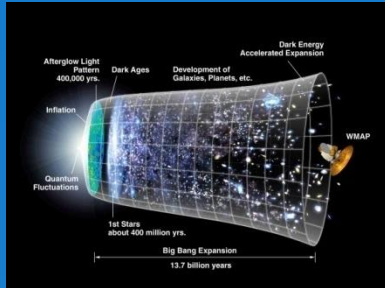

Heelal
 10^{26} m

Spin
 10^{-2} m



Melkweg
 10^{21} m

Atoom
 10^{-10} m

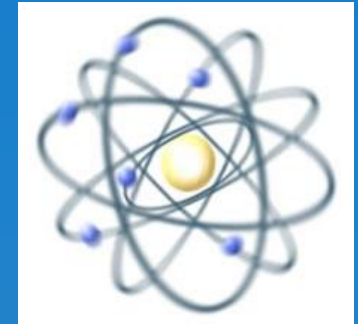

Zonnestelsel
 10^{13} m

Kern
 10^{-15} m

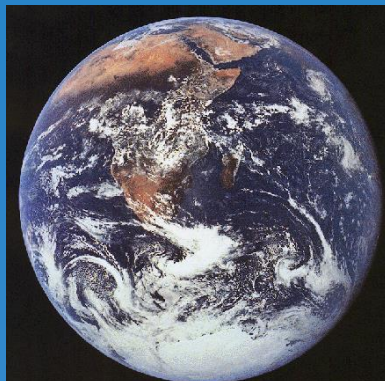
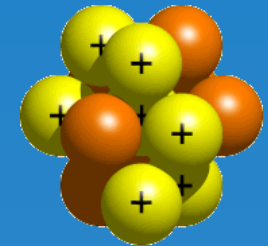

Aarde
 10^7 m

Botsingen
 10^{-18} m

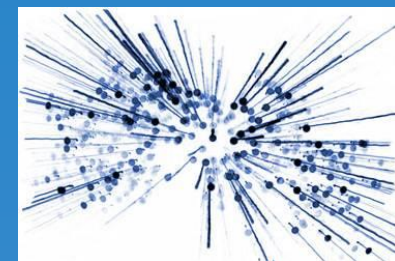

De stand van zaken in 2013



[http:// pdg.lbl.gov](http://pdg.lbl.gov)

De elementaire deeltjes

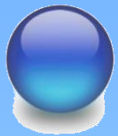

up

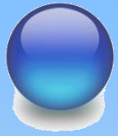

down

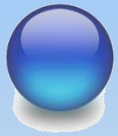

elektron

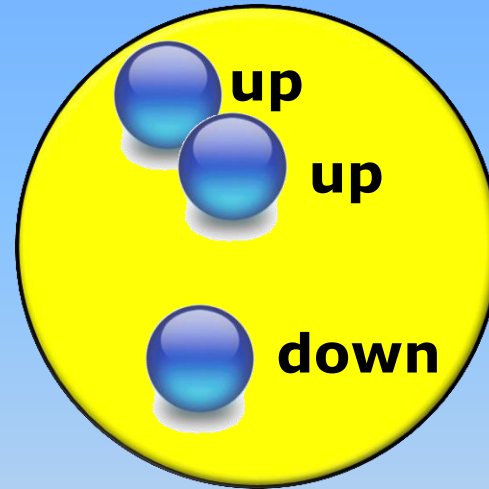

Proton

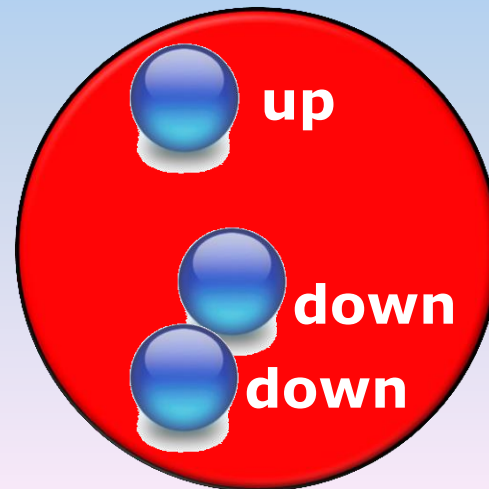

Neutron

Wat kan je maken van deze 3 bouwstenen?

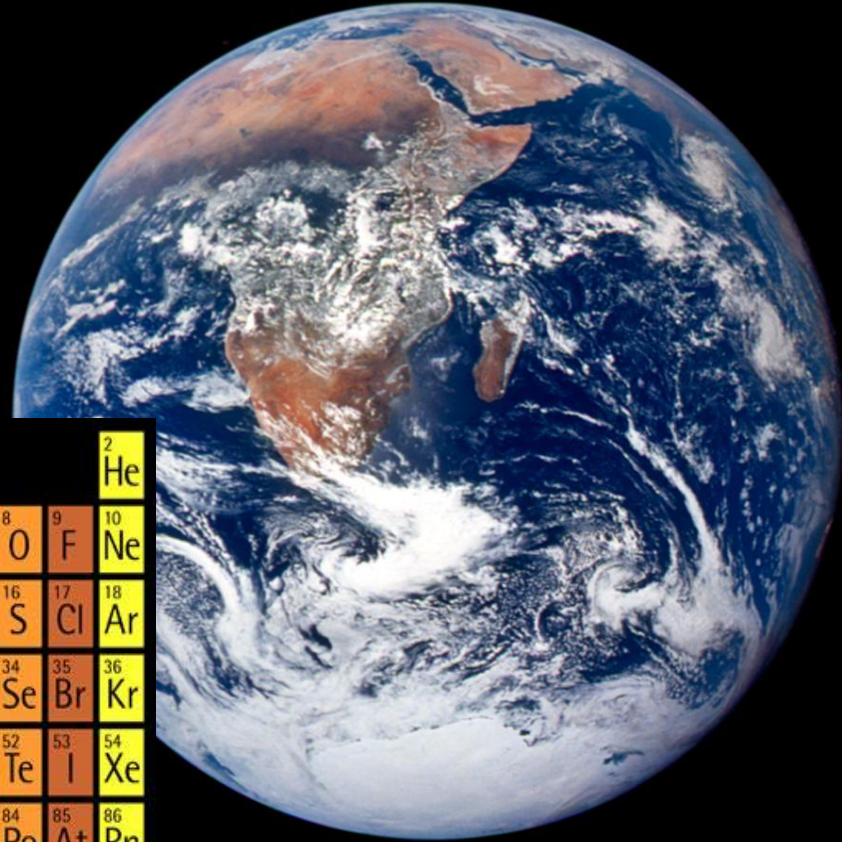
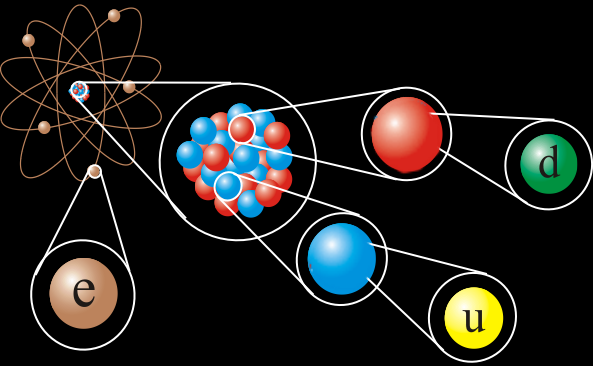

periodiek systeem
van Mendeleev

1 H																	2 He
3 Li	4 Be											5 B	6 C	7 N	8 O	9 F	10 Ne
11 Na	12 Mg											13 Al	14 Si	15 P	16 S	17 Cl	18 Ar
19 K	20 Ca	21 Sc	22 Ti	23 V	24 Cr	25 Mn	26 Fe	27 Co	28 Ni	29 Cu	30 Zn	31 Ga	32 Ge	33 As	34 Se	35 Br	36 Kr
37 Rb	38 Sr	39 Y	40 Zr	41 Nb	42 Mo	43 Tc	44 Ru	45 Rh	46 Pd	47 Ag	48 Cd	49 In	50 Sn	51 Sb	52 Te	53 I	54 Xe
55 Cs	56 Ba	71 Lu	72 Hf	73 Ta	74 W	75 Re	76 Os	77 Ir	78 Pt	79 Au	80 Hg	81 Tl	82 Pb	83 Bi	84 Po	85 At	86 Rn
87 Fr	88 Ra	103 Lr	104 Rf	105 Db	106 Sg	107 Bh	108 Hs	109 Mt									

57 La	58 Ce	59 Pr	60 Nd	61 Pm	62 Sm	63 Eu	64 Gd	65 Tb	66 Dy	67 Ho	68 Er	69 Tm	70 Yb
89 Ac	90 Th	91 Pa	92 U	93 Np	94 Pu	95 Am	96 Cm	97 Bk	98 Cf	99 Es	100 Fm	101 Md	102 No

Alles!

Het aantal elementaire deeltjes...

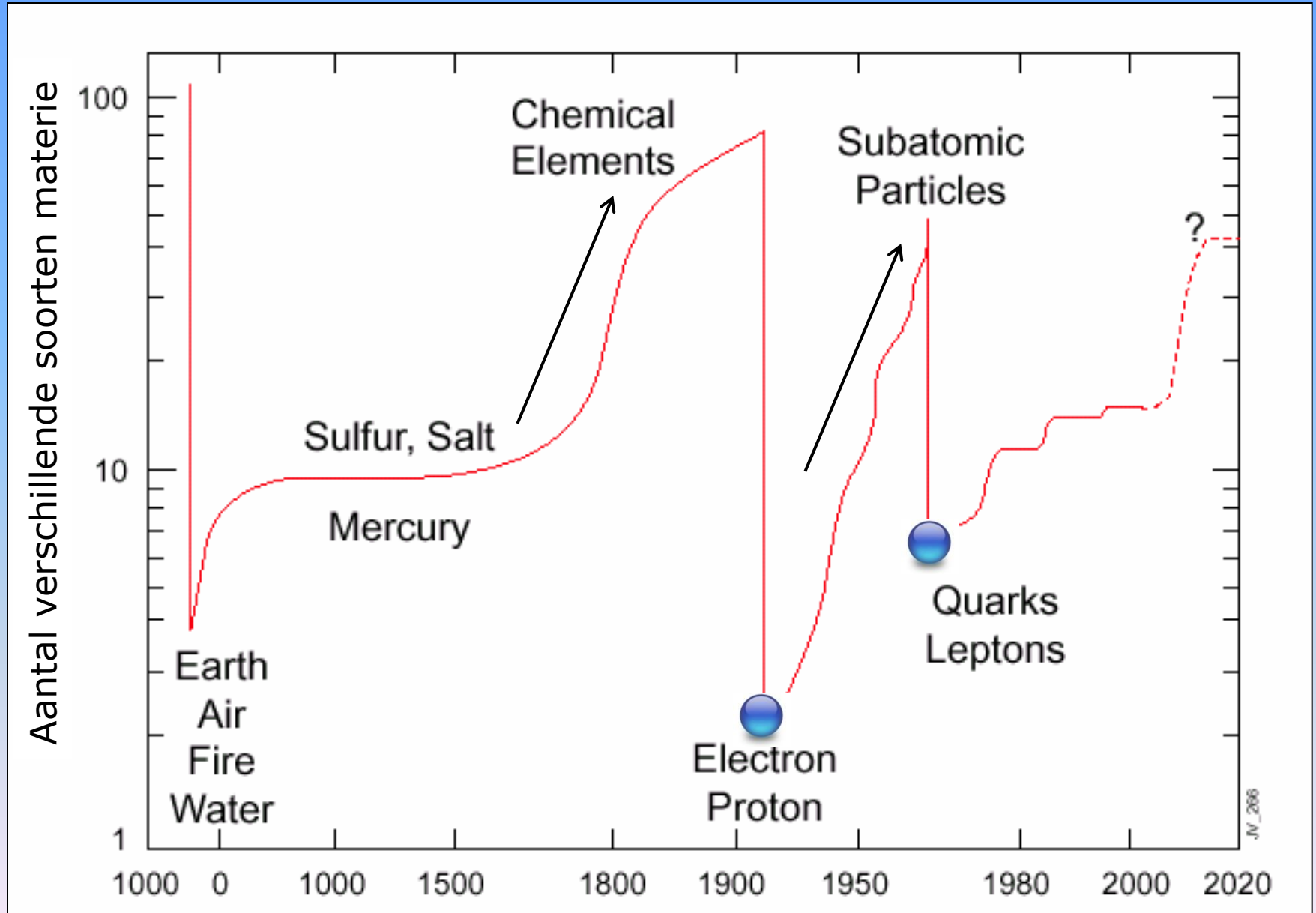



Quarks	u up	c charm	t top
	d down	s strange	b bottom

Leptons	ν_e electron neutrino	ν_μ muon neutrino	ν_τ tau neutrino
	e electron	μ muon	τ tau

γ photon	Force carriers
Z Z boson	
W W boson	
g gluon	

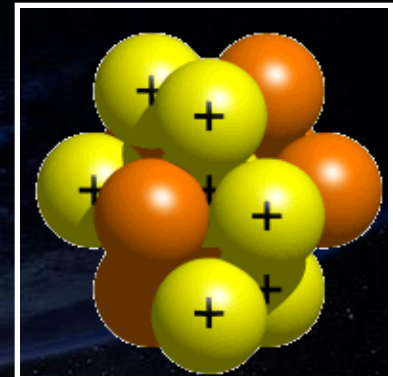
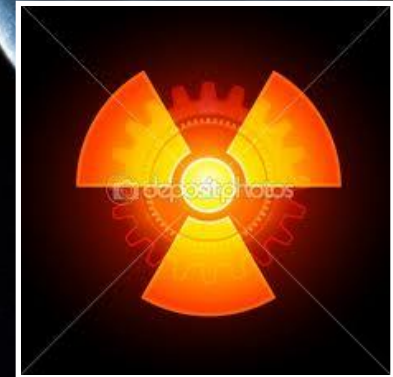

12 deeltjes

4 krachten



Wat snappen we nog niet



Wat snappen we nog niet?

Massa van deeltjes

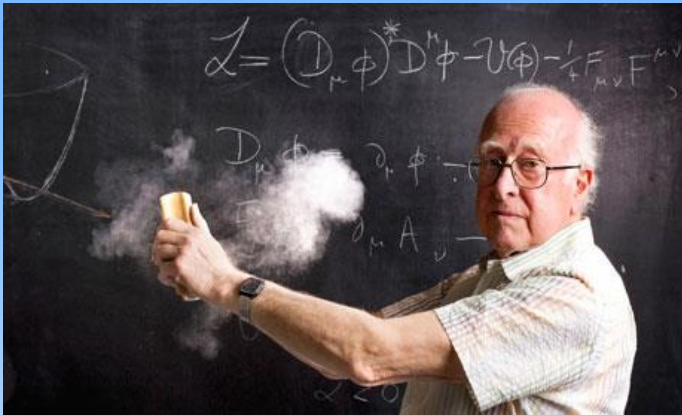

Bijzondere voorspelling:

Het Higgs boson:

zorgt ervoor dat deeltjes massa kunnen hebben in de theorie



Wat is massa ?? Anno 1687

Massa is de 'wisselkoers' tussen kracht en versnelling:

$$F = m \times a$$

Beschrijft niet wat massa **is** ...



Newton

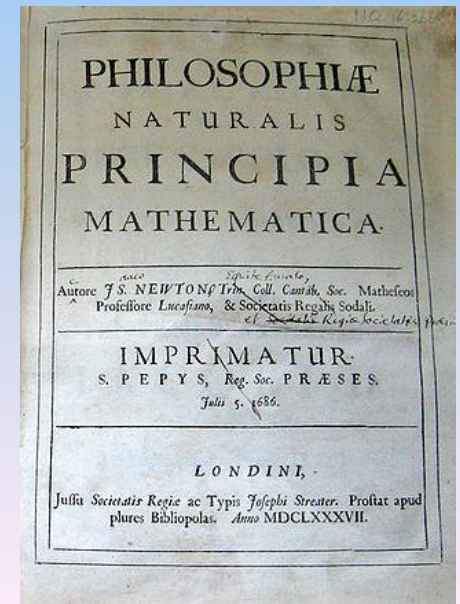

Wat is massa ?? Anno 1905

Massa is energie

$$E = m \times c^2$$

Beschrijft wel wat massa **is** !

Maar niet waar het vandaan komt ...

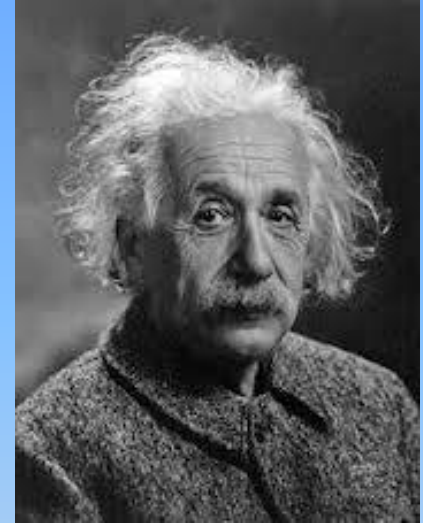

Einstein

13. *Ist die Trägheit eines Körpers von seinem Energieinhalt abhängig?*
von A. Einstein.

Die Resultate einer jüngst in diesen Annalen von mir publizierten elektrodynamischen Untersuchung¹⁾ führen zu einer sehr interessanten Folgerung, die hier abgeleitet werden soll. Ich legte dort die Maxwell-Hertz'schen Gleichungen für den leeren Raum nebst dem Maxwellschen Ausdruck für die elektromagnetische Energie des Raumes zugrunde und außerdem das Prinzip:

Die Gesetze, nach denen sich die Zustände der physikalischen Systeme ändern, sind unabhängig davon, auf welches von zwei relativ zueinander in gleichförmiger Parallel-Translationsbewegung befindlichen Koordinatensystemen diese Zustandsänderungen bezogen werden (Relativitätsprinzip).

Gestützt auf diese Grundlagen²⁾ leitete ich unter anderem das nachfolgende Resultat ab (l. c. § 8):

Ein System von ebenen Lichtwellen besitze, auf das Koordinatensystem (x, y, z) bezogen, die Energie l ; die Strahlrichtung (Wellennormale) bilde den Winkel φ mit der x -Achse des Systems. Führt man ein neues, gegen das System (x, y, z) in gleichförmiger Paralleltranslation begriffenes Koordinatensystem (ξ, η, ζ) ein, dessen Ursprung sich mit der Geschwindigkeit v längs der x -Achse bewegt, so besitzt die genannte Lichtmenge — im System (ξ, η, ζ) gemessen — die Energie:

$$l^* = l \frac{1 - \frac{v}{V} \cos \varphi}{\sqrt{1 - \left(\frac{v}{V}\right)^2}}$$

wobei V die Lichtgeschwindigkeit bedeutet. Von diesem Resultat machen wir im folgenden Gebrauch.

1) A. Einstein, Ann. d. Phys. 17, p. 891. 1905.

2) Das dort benutzte Prinzip der Konstanz der Lichtgeschwindigkeit ist natürlich in den Maxwellschen Gleichungen enthalten.

Wat is massa ?? Anno 1964

Massa van elementaire deeltjes komt door
 “wrijving” met alomtegenwoordig ‘Higgs veld’

$$m: \psi\psi H$$

Huh?

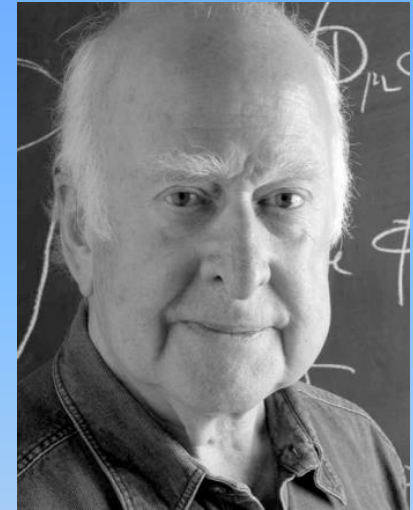

Higgs

BROKEN SYMMETRIES, MASSLESS PARTICLES AND GAUGE FIELDS
 D. M. HIGGS
 The Institute of Mathematical Physics, University of Edinburgh, Scotland
 Received 21 July 1964

Recently a number of people have discussed the Goldstone theorem^{1,2} in any solution of a Lorentz-invariant theory which violates an internal symmetry operation of that theory such as the massless scalar particle. Kibble and Lee³ showed that this theorem does not necessarily apply to non-relativistic theories and argued that their considerations would apply equally well to Lorentz-invariant field theories. Gilbert⁴, however, gave a proof that the failure of the Goldstone theorem in the non-relativistic case is of a type which could not allow Lorentz invariance to be imposed on a theory. The purpose of this note is to show that Gilbert's argument fails for an important class of field theories, that in which the conserved currents are coupled to gauge fields. Following the procedure used by Utiyama⁵, let us consider a theory of two fermionic scalar fields

$\psi_1(x), \psi_2(x)$ which is invariant under the phase transformations

$$\psi_1 \rightarrow e^{i\alpha} \psi_1 + e^{i\beta} \psi_2$$

$$\psi_2 \rightarrow -e^{i\alpha} \psi_2 + e^{i\beta} \psi_1$$

This theory is a conserved current J_μ such that

$$\partial_\mu J^\mu = 0$$

We assume that the Lagrangian is such that symmetry is broken by the spontaneous of the vacuum expectation value of ψ_1 . Goldstone's theorem is proved by showing that the Fourier transform of $\langle \psi_1(x), \psi_1(0) \rangle$ contains a term

$$\delta^4(p) \delta(p^2) \delta(p_0)$$

as a consequence of Lorentz invariance, the conservation law and eq. (1).

Kibble and Lee³ avoided this result in the non-relativistic case by showing that the more general form of the Fourier transform is now, in Gilbert's notation,

$$F(\mathbf{p}, \omega) = \delta^3(\mathbf{p}) \delta(\omega - \omega_0) \delta(\omega^2 - \omega_0^2)$$

where ω_0 which may be taken as 0, is, of course, the energy in a special Lorentz frame. The conservation law then reduces eq. (2) to the less general

instead of order to define a radiation gauge in which the vector gauge fields are well defined operators. Such theories are nevertheless Lorentz-invariant, as has been shown by Schwinger⁶. (This has, of course, long been known of the special such theory, quantum electrodynamics.) There seems to be no reason why the vector ω_μ should not appear in the Fourier transform under consideration.

It is characteristic of gauge theories that the conservation laws hold in the strong sense, as a consequence of field equations of the form

$$\partial_\mu F^{\mu\nu} = j^\nu$$

Except in the case of Abelian gauge theories, the fields $A_\mu, F_{\mu\nu}$ are not simply the gauge field variables. $F_{\mu\nu}$ the contain additional terms with coefficients of the structure constants of the group in question. Now the structure of the Fourier transform of $\langle \psi_1(x), \psi_1(0) \rangle$ must be given by eq. (2). Applying eq. (3) to this commutator gives us as the Fourier transform of $\langle \psi_1(x), \psi_1(0) \rangle$ the single term

$$[j^\mu(x), \psi_1(0)] \delta^4(x)$$

which then reduces eq. (2) to the less general

Wat is massa ?? Anno 1964

Massa van elementaire deeltjes komt door

“wrijving” met alomtegenwoordig ‘Higgs veld’

$$m: \psi\psi H$$

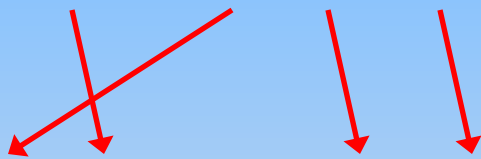

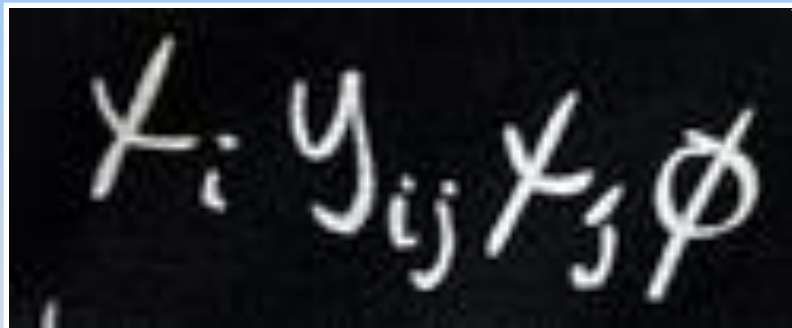
$$\mathcal{L} = -\frac{1}{4} F_{\mu\nu} F^{\mu\nu} + i\bar{\psi}\not{D}\psi + h.c. + \chi_i y_{ij} \chi_j \phi + h.c. + |D_\mu \phi|^2 - V(\phi)$$

Prof. dr John Ellis

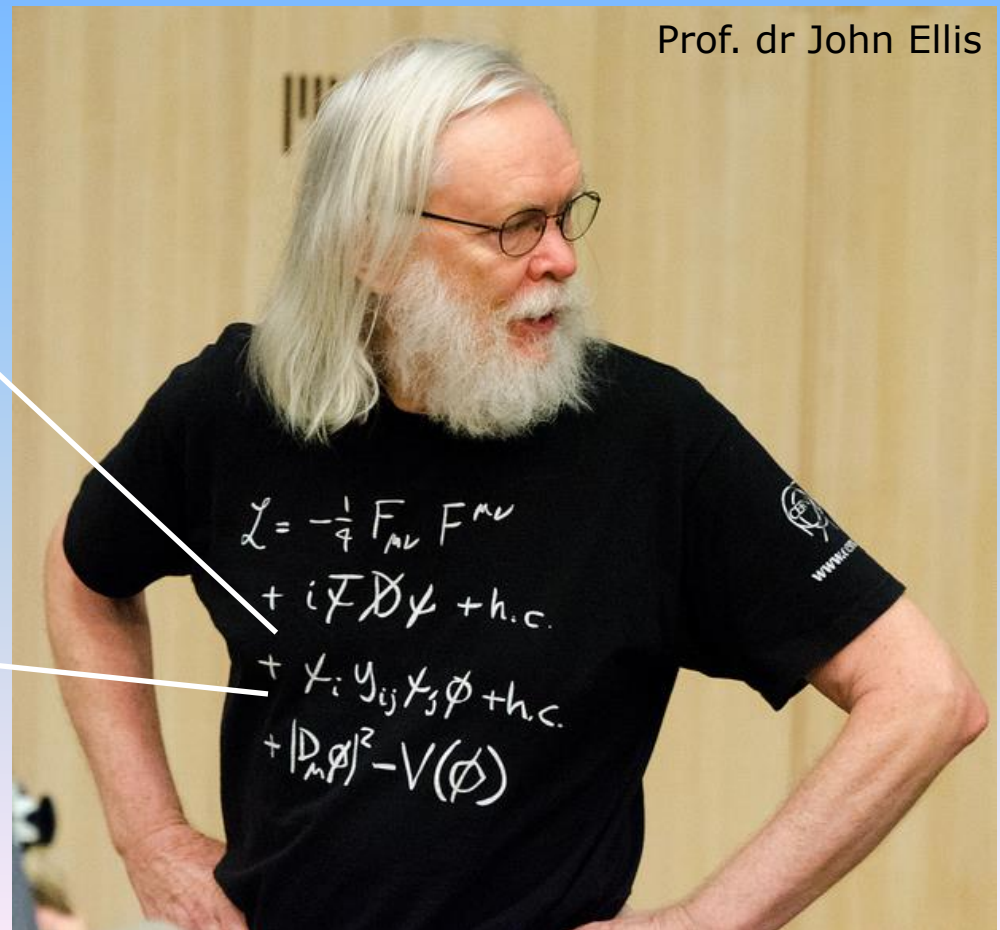

Modelleren van interactie

Standaard Model Lagrangiaan

$$\begin{aligned}
 & -\frac{1}{2}\partial_\nu g_\mu^a \partial_\nu g_\mu^a - g_s f^{abc} \partial_\mu g_\mu^a g_\mu^b g_\mu^c - \frac{1}{4}g_s^2 f^{abc} f^{ade} g_\mu^a g_\mu^b g_\mu^c g_\mu^d g_\mu^e + \frac{1}{2}ig_\mu^2 (g_\mu^a \gamma^\mu g_\mu^a) g_\mu^a + \\
 & \bar{G}^a \partial^2 G^a + g_s f^{abc} \partial_\mu \bar{G}^a G^b g_\mu^c - \partial_\mu W_\mu^+ \partial_\nu W_\nu^- - M^2 W_\mu^+ W_\mu^- - \frac{1}{2}\partial_\nu Z_\nu^0 Z_\nu^0 - \frac{1}{2}g^2 M^2 Z_\nu^0 Z_\nu^0 - \\
 & \frac{1}{2}\partial_\mu A_\nu \partial_\mu A_\nu - \frac{1}{2}\partial_\mu H \partial_\mu H - \frac{1}{2}m_H^2 H^2 - \partial_\mu \phi^+ \partial_\mu \phi^- - M^2 \phi^+ \phi^- - \frac{1}{2}\partial_\mu \phi^0 \partial_\mu \phi^0 - \\
 & \frac{1}{2c_w^2} M \phi^0 \phi^0 - \beta_h \left[\frac{2M^2}{g^2} + \frac{2M}{g} H + \frac{1}{2} (H^2 + \phi^0 \phi^0 + 2\phi^+ \phi^-) \right] + \frac{2M^2}{g^2} \alpha_h - ig_{cw} [\partial_\nu Z_\nu^0 (W_\mu^+ W_\nu^- - \\
 & W_\mu^- W_\nu^+) - Z_\nu^0 (W_\mu^+ \partial_\nu W_\mu^- - W_\mu^+ \partial_\nu W_\mu^+) + Z_\nu^0 (W_\nu^+ \partial_\mu W_\mu^- - W_\nu^- \partial_\mu W_\mu^+) - ig_{sw} (\partial_\nu A_\mu (W_\mu^+ W_\nu^- - \\
 & W_\mu^- W_\nu^+) - A_\nu (W_\mu^+ \partial_\nu W_\mu^- - W_\mu^- \partial_\nu W_\mu^+) + A_\nu (W_\nu^+ \partial_\mu W_\mu^- - W_\nu^- \partial_\mu W_\mu^+)] - \frac{1}{2}g^2 W_\mu^+ W_\nu^- W_\nu^+ W_\mu^- + \\
 & \frac{1}{2}g^2 W_\mu^+ W_\nu^- W_\nu^+ W_\mu^- + g^2 c_w^2 (Z_\nu^0 W_\mu^+ Z_\nu^0 W_\nu^- - Z_\nu^0 Z_\mu^0 W_\nu^+ W_\nu^-) + g^2 s_w^2 (A_\mu W_\mu^+ A_\nu W_\nu^- - \\
 & A_\mu A_\nu W_\mu^+ W_\nu^-) + g^2 s_w c_w [A_\mu Z_\nu^0 (W_\mu^+ W_\nu^- - W_\mu^- W_\nu^+) - 2A_\nu Z_\mu^0 W_\nu^+ W_\nu^-] - g\alpha [H^3 + \\
 & H \phi^0 \phi^0 + 2H \phi^+ \phi^-] - \frac{1}{8}g^2 \alpha_h [H^4 + (\phi^0)^4 + 4(\phi^+ \phi^-)^2 + 4(\phi^0)^2 \phi^+ \phi^- + 4H^2 \phi^+ \phi^- + \\
 & 2(\phi^0)^2 H^2] - g M W_\mu^+ W_\nu^- H - \frac{1}{2}g \frac{M}{c_w} Z_\nu^0 Z_\mu^0 H - \frac{1}{2}ig [W_\mu^+ (\phi^0 \partial_\mu \phi^- - \phi^- \partial_\mu \phi^0) - W_\mu^- (\phi^0 \partial_\mu \phi^+ - \\
 & \phi^+ \partial_\mu \phi^0)] + \frac{1}{2}ig [W_\mu^+ (H \partial_\mu \phi^- - \phi^- \partial_\mu H) - W_\mu^- (H \partial_\mu \phi^+ - \phi^+ \partial_\mu H)] + \frac{1}{2}g \frac{1}{c_w} [Z_\nu^0 (H \partial_\nu \phi^0 - \\
 & \phi^0 \partial_\nu H) - ig \frac{s_w}{c_w} M Z_\nu^0 (W_\mu^+ \phi^- - W_\mu^- \phi^+) + ig_{sw} M A_\mu (W_\mu^+ \phi^- - W_\mu^- \phi^+) - ig \frac{1-2c_w^2}{2c_w} Z_\mu^0 (\phi^+ \partial_\mu \phi^- - \\
 & \phi^- \partial_\mu \phi^+) + ig_{sw} A_\mu (\phi^+ \partial_\mu \phi^- - \phi^- \partial_\mu \phi^+) - \frac{1}{4}g^2 W_\mu^+ W_\nu^- [H^2 + (\phi^0)^2 + 2\phi^+ \phi^-] - \\
 & \frac{1}{4}g^2 \frac{1}{c_w} Z_\nu^0 Z_\mu^0 [H^2 + (\phi^0)^2 + 2(2s_w^2 - 1)^2 \phi^+ \phi^-] - \frac{1}{2}g^2 \frac{s_w^2}{c_w} Z_\mu^0 \phi^0 (W_\mu^+ \phi^- + W_\mu^- \phi^+) - \\
 & \frac{1}{2}ig^2 \frac{s_w^2}{c_w} Z_\mu^0 H (W_\mu^+ \phi^- - W_\mu^- \phi^+) + \frac{1}{2}g^2 s_w A_\mu \phi^0 (W_\mu^+ \phi^- + W_\mu^- \phi^+) + \frac{1}{2}ig^2 s_w A_\mu H (W_\mu^+ \phi^- - \\
 & W_\mu^- \phi^+) - g^2 \frac{s_w}{c_w} (2c_w^2 - 1) Z_\mu^0 A_\mu \phi^+ \phi^- - g^2 s_w^2 A_\mu A_\nu \phi^+ \phi^- - e^\lambda (\gamma \partial + m_\Delta^2) e^\lambda - \\
 & \bar{\nu}^\lambda \gamma \partial \nu^\lambda - \bar{u}_2^j (\gamma \partial + m_\Delta^2) u_2^j - \bar{d}_2^j (\gamma \partial + m_\Delta^2) d_2^j + ig_{sw} A_\mu [-(e^\lambda \gamma^\mu e^\lambda) + \frac{2}{3}(\bar{u}_2^j \gamma^\mu u_2^j) - \\
 & \frac{1}{3}(\bar{d}_2^j \gamma^\mu d_2^j)] + \frac{ig}{4c_w} Z_\nu^0 [(\bar{\nu}^\lambda \gamma^\mu (1 + \gamma^5) \nu^\lambda) + (e^\lambda \gamma^\mu (4s_w^2 - 1 - \gamma^5) e^\lambda) + (\bar{u}_2^j \gamma^\mu (\frac{2}{3}s_w^2 - \\
 & 1 - \gamma^2) u_2^j) + (\bar{d}_2^j \gamma^\mu (1 - \frac{2}{3}s_w^2 - \gamma^2) d_2^j)] + \frac{ig}{2\sqrt{2}} W_\mu^+ [(\bar{\nu}^\lambda \gamma^\mu (1 + \gamma^5) e^\lambda) + (\bar{u}_2^j \gamma^\mu (1 + \\
 & \gamma^5) C_{\lambda\lambda} d_2^j) + \frac{ig}{2\sqrt{2}} W_\mu^- [(e^\lambda \gamma^\mu (1 + \gamma^5) \nu^\lambda) + (\bar{d}_2^j C_{\lambda\lambda} \gamma^\mu (1 + \gamma^5) u_2^j)] + \frac{ig}{2\sqrt{2}} \frac{m_\Delta^2}{M} [-\phi^+ (\bar{\nu}^\lambda (1 - \\
 & \gamma^5) e^\lambda) + \phi^- (e^\lambda (1 + \gamma^5) \nu^\lambda)] - \frac{g}{2} \frac{m_\Delta^2}{M} [H (e^\lambda e^\lambda) + i\phi^0 (e^\lambda \gamma^5 e^\lambda)] + \frac{ig}{2M\sqrt{2}} \phi^+ [-m_\Delta^2 (\bar{u}_2^j C_{\lambda\lambda} (1 - \\
 & \gamma^5) d_2^j) + m_\Delta^2 (\bar{u}_2^j C_{\lambda\lambda} (1 + \gamma^5) d_2^j) + \frac{ig}{2M\sqrt{2}} \phi^- [m_\Delta^2 (\bar{d}_2^j C_{\lambda\lambda} (1 + \gamma^5) u_2^j) - m_\Delta^2 (\bar{d}_2^j C_{\lambda\lambda} (1 - \\
 & \gamma^5) u_2^j)] - \frac{g}{2} \frac{m_\Delta^2}{M} H (\bar{u}_2^j u_2^j) - \frac{g}{2} \frac{m_\Delta^2}{M} H (\bar{d}_2^j d_2^j) + \frac{ig}{2} \frac{m_\Delta^2}{M} \phi^0 (\bar{u}_2^j \gamma^5 u_2^j) - \frac{ig}{2} \frac{m_\Delta^2}{M} \phi^0 (\bar{d}_2^j \gamma^5 d_2^j) + \\
 & \bar{X} + (\partial^2 - M^2) X + \bar{X} - (\partial^2 - M^2) X - \bar{X}^0 (\partial^2 - \frac{M^2}{c_w^2}) X^0 + Y \partial Y + ig_{cw} W_\mu^+ (\partial_\mu \bar{X}^0 X - \\
 & \partial_\mu \bar{X}^0 X^0) + ig_{sw} W_\mu^+ (\partial_\nu \bar{Y} X - \partial_\nu \bar{X} Y) + ig_{cw} W_\mu^- (\partial_\mu \bar{X} - X^0 - \partial_\mu \bar{X}^0 X^+) + \\
 & ig_{sw} W_\mu^- (\partial_\mu \bar{X} - Y - \partial_\mu \bar{Y} X^+) + ig_{cw} Z_\mu^0 (\partial_\mu \bar{X}^+ X^+ - \partial_\mu \bar{X}^- X^-) + ig_{sw} A_\mu (\partial_\mu \bar{X}^+ X^+ - \\
 & \partial_\mu \bar{X}^- X^-) - \frac{1}{2}g M [\bar{X}^+ X^+ H + \bar{X}^- X^- H + \frac{1}{c_w} \bar{X}^0 X^0 H] + \frac{1-2c_w^2}{2c_w} ig M [\bar{X}^+ X^0 \phi^+ - \\
 & \bar{X}^- X^0 \phi^-] + \frac{1}{2c_w} ig M [\bar{X}^0 X^- \phi^+ - \bar{X}^0 X^+ \phi^-] + ig M s_w [\bar{X}^0 X^- \phi^+ - \bar{X}^0 X^+ \phi^-] + \\
 & \frac{1}{2}ig M [\bar{X}^+ X^+ \phi^0 - \bar{X}^- X^- \phi^0]
 \end{aligned}$$

Bladmuziek (J.S. Bach) bladmuziek



Ho ho ho...

Laten we eerst eens kijken hoe we deeltjes bestuderen...

Kijken zonder je ogen te gebruiken



Kijken

Kijken is verstrooiing van licht

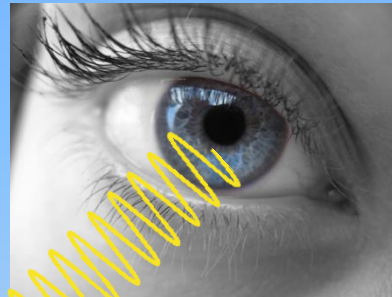

'gespleten haarpunt'

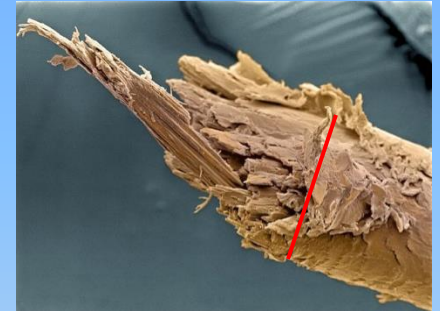

Je kunt geen dingen zien die *kleiner* zijn dan de golflengte van het licht (ca 1/50 haardikte)

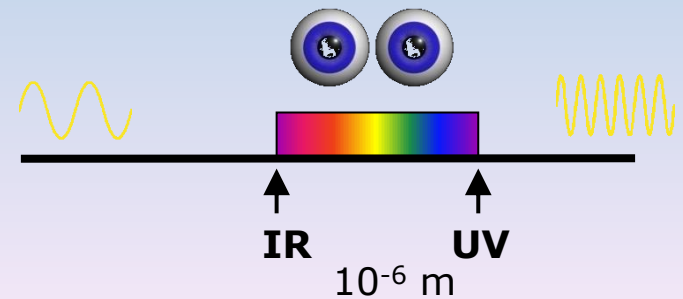

Kijken

Kijken is ook verstrooiing van *deeltjes*

Vervang oog door *detector*

→ Elektronen microscoop

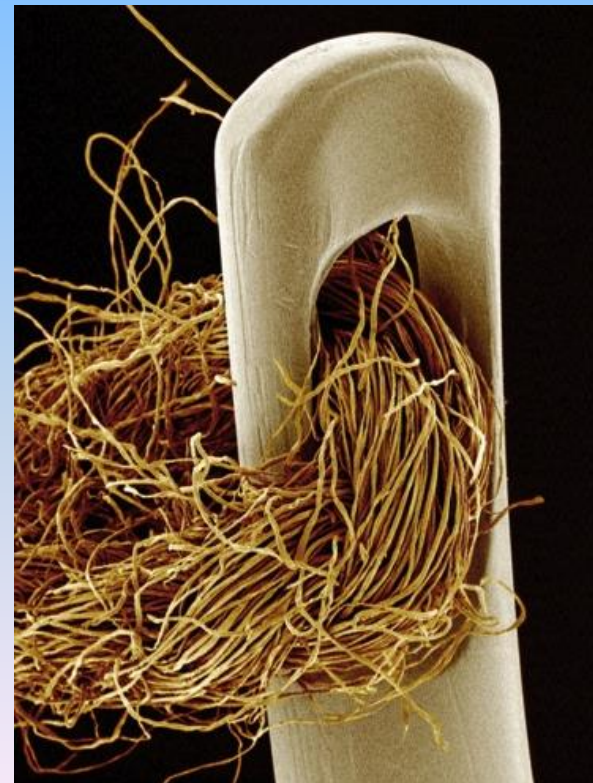
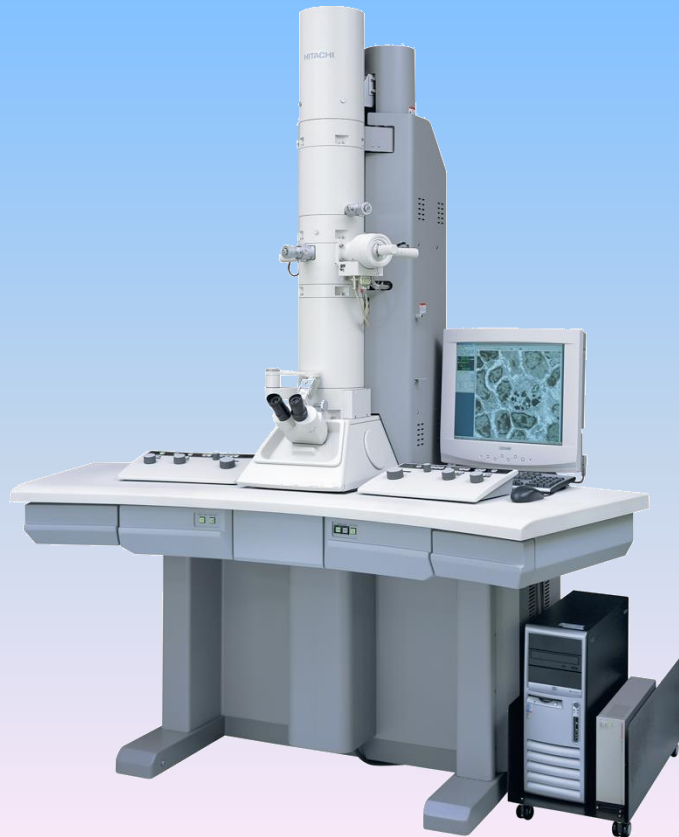

Het electro-magnetische spectrum

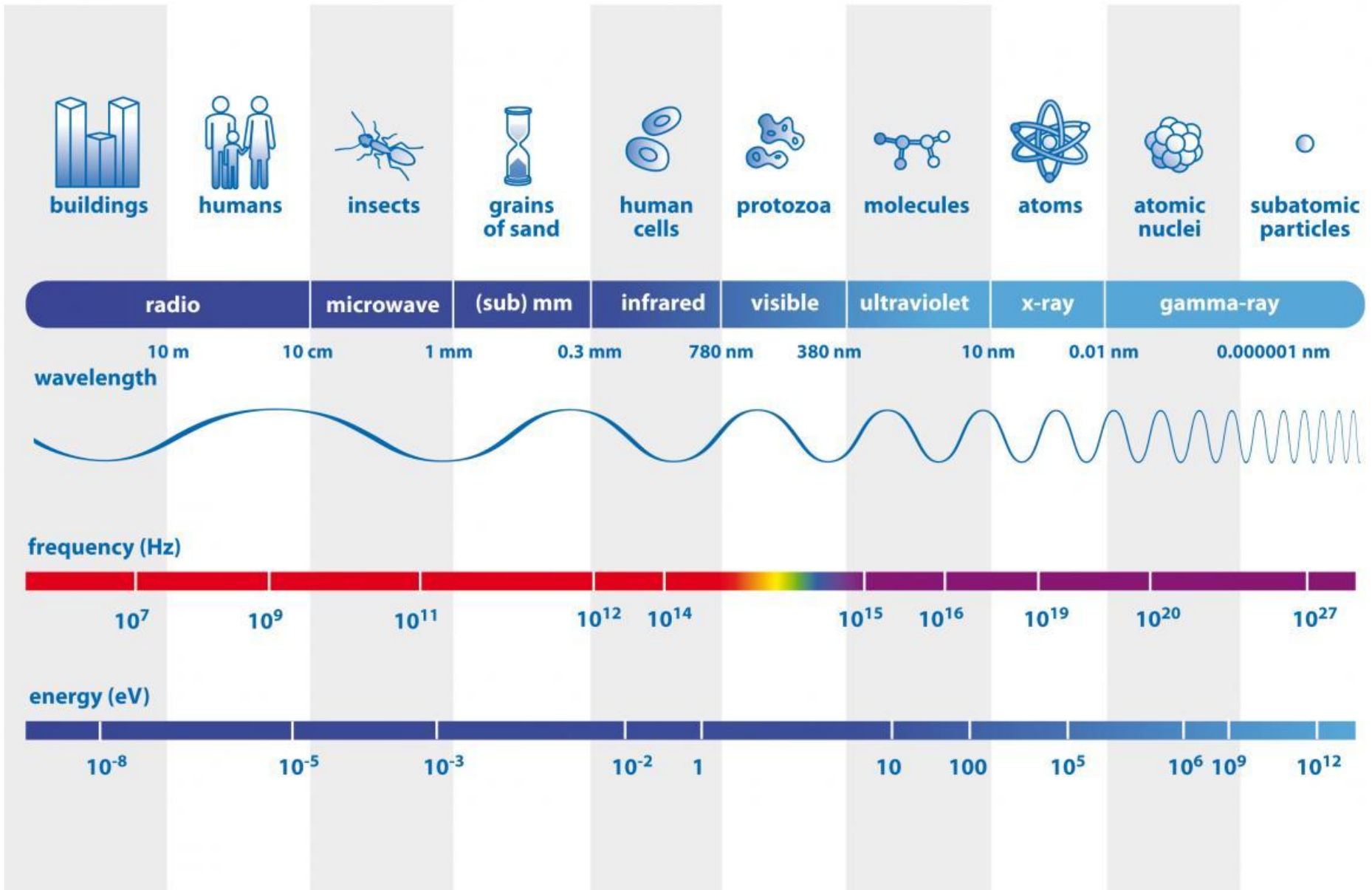

An aerial photograph of the Geneva region in Switzerland, showing the city, surrounding green fields, and distant snow-capped mountains. A large red oval is drawn over the landscape, representing the circular path of the Large Hadron Collider (LHC) tunnel. The oval is centered over the city of Geneva. A blue text box with a white border is overlaid on the lower part of the oval.

De grootste microscoop op aarde
de Large Hadron Collider (LHC)
op CERN bij Genève

De LHC deeltjesversneller

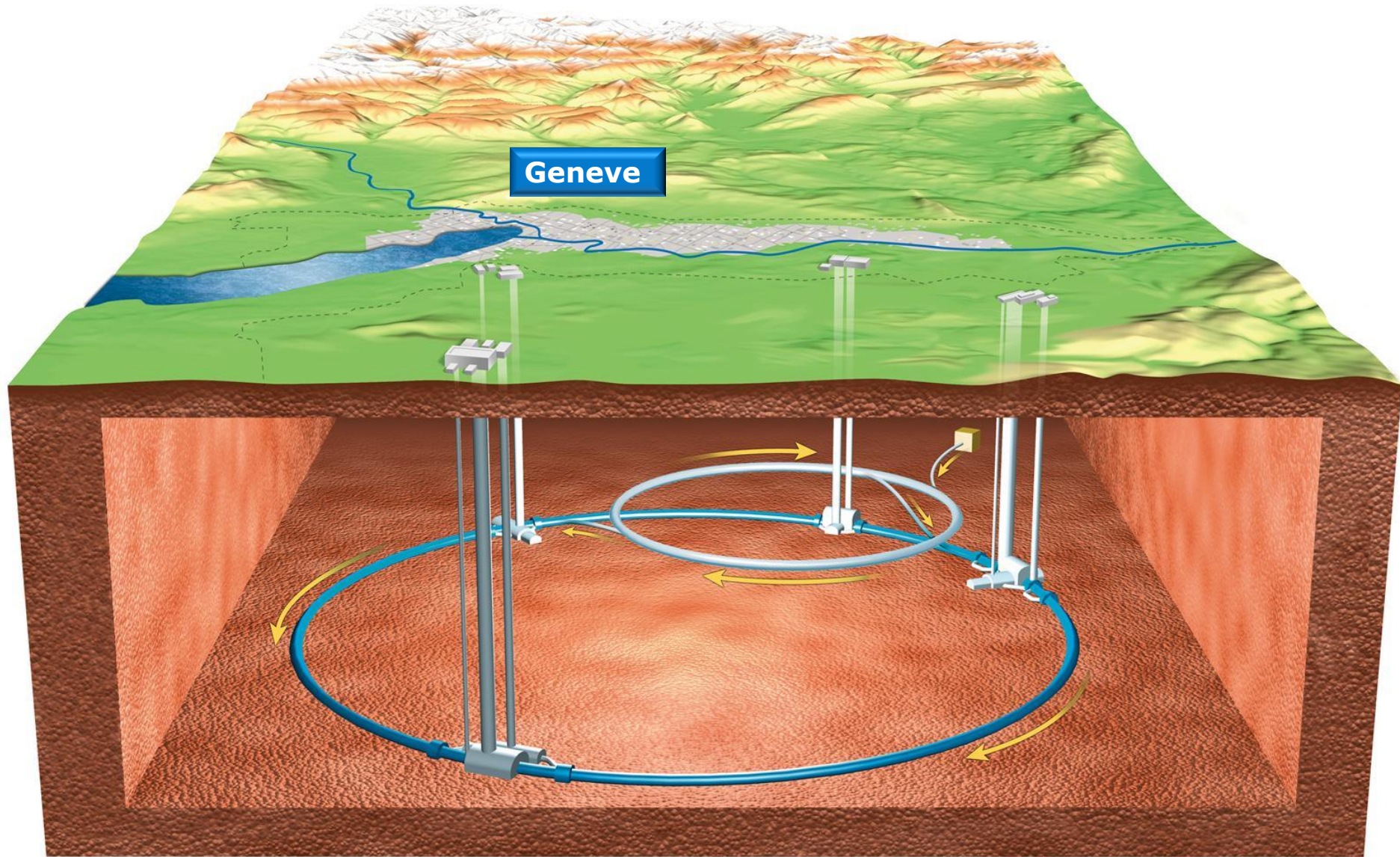

De Large Hadron Collider

LHC: 27 km



A10: 32 km



The LHC machine



Energie is gelimiteerd door de kracht
van 1232 dipool magneten: $B = 8.4 \text{ T}$
(Aardmagnetisch veld: 0.00005 T)

40 miljoen botsingen per seconde

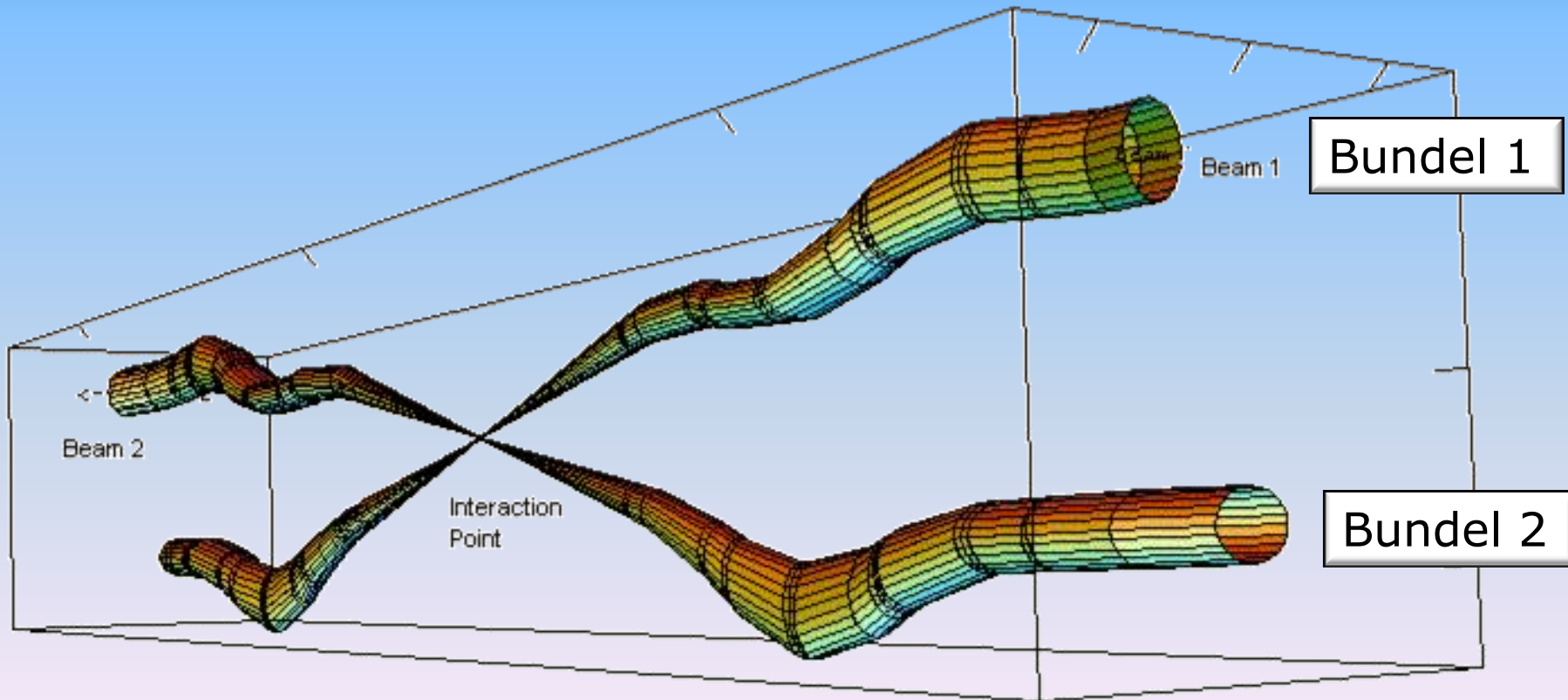



Klassiek botsen

Quantummechanisch botsen



Botsingen van Deeltjes

PLAY ▶

Large Hadron Collider

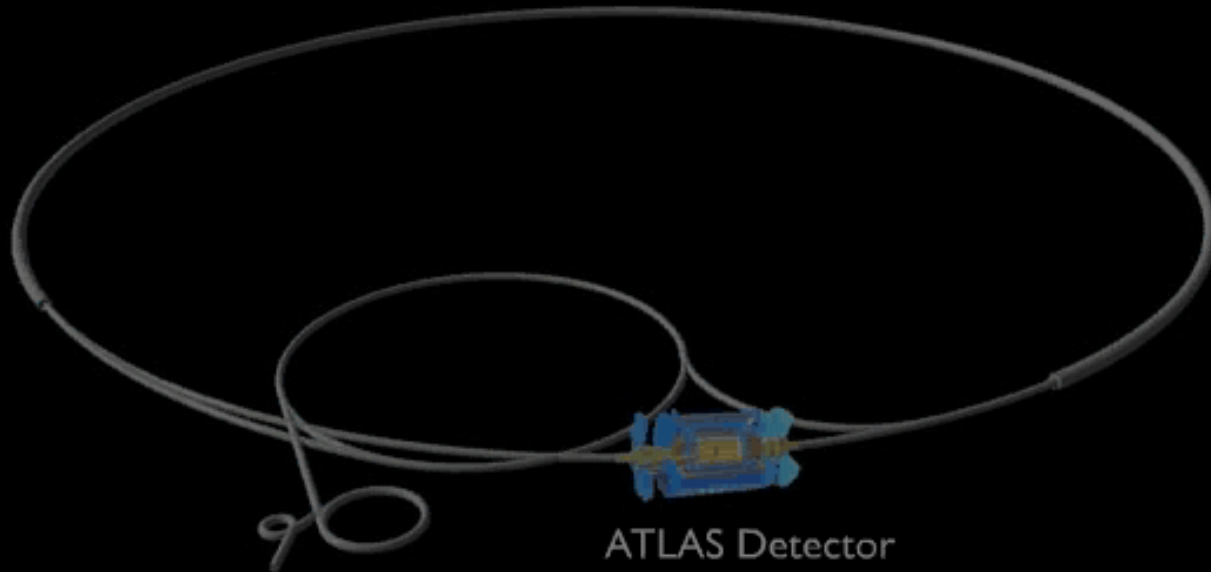

ATLAS Detector

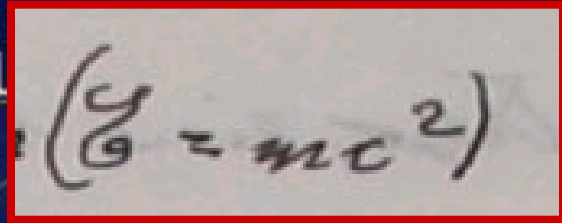
$$E = mc^2$$

Hoe ontdekken we nieuwe deeltjes?

Bij de LHC op Cern:
Verander energie in materie!

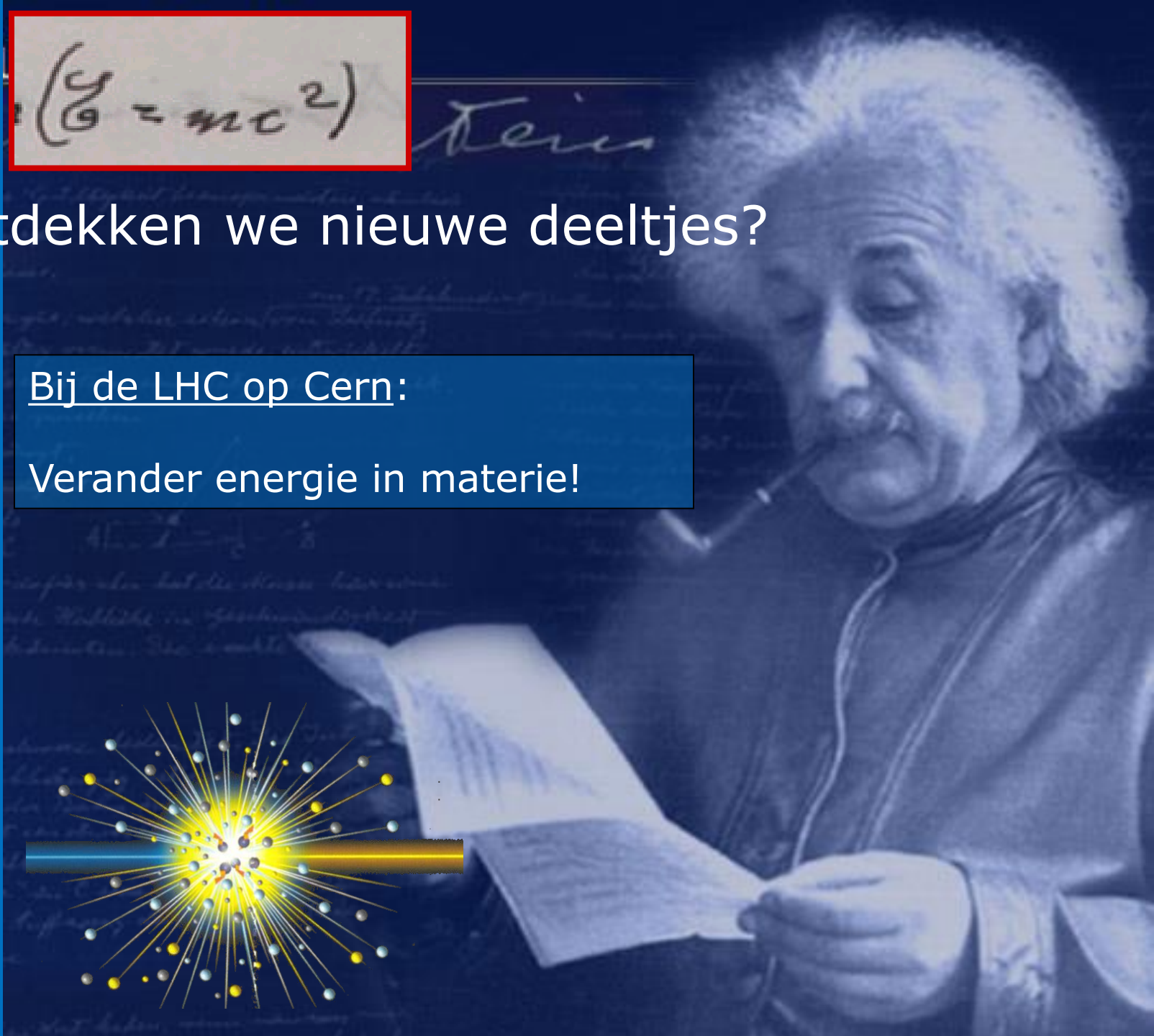
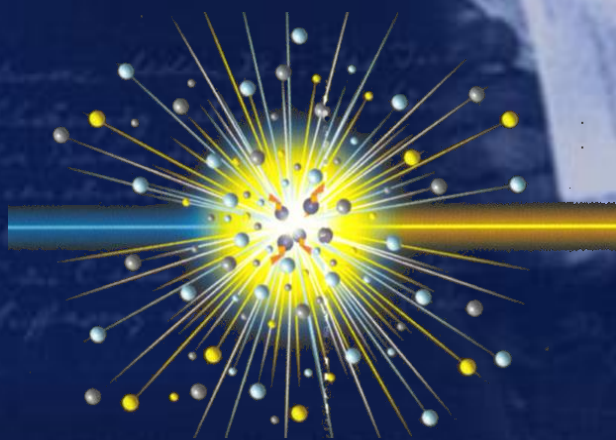

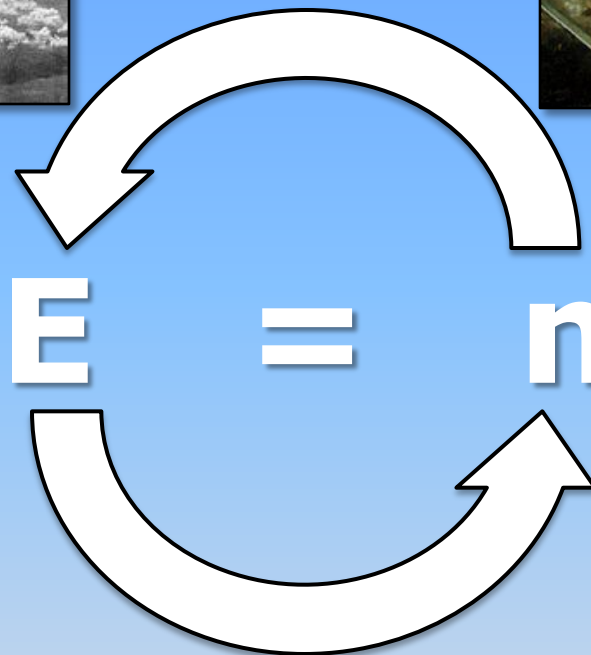

$$E = mc^2$$



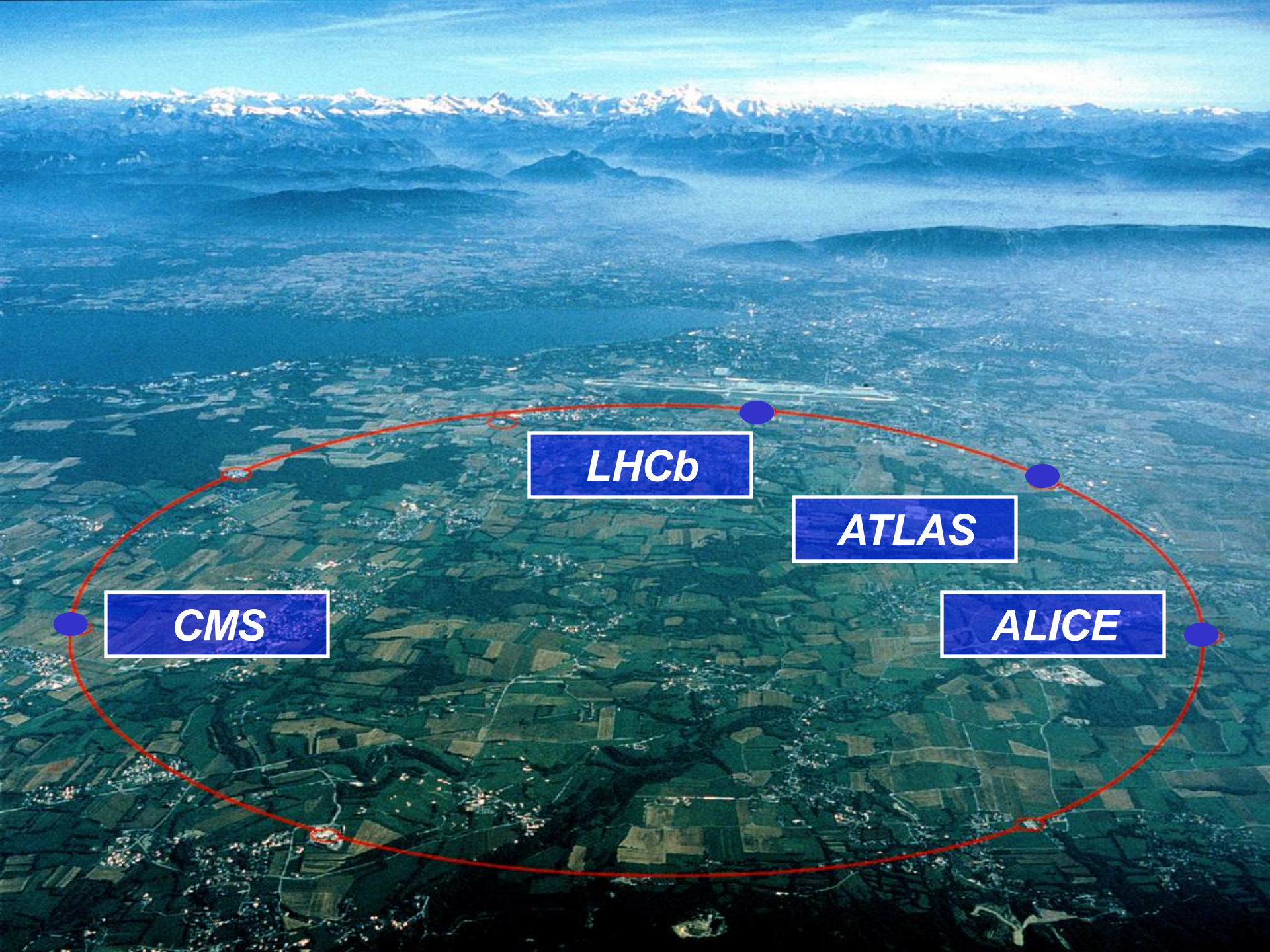

LHCb

ATLAS

CMS

ALICE

Hoe zien die botsingen er nou uit ?

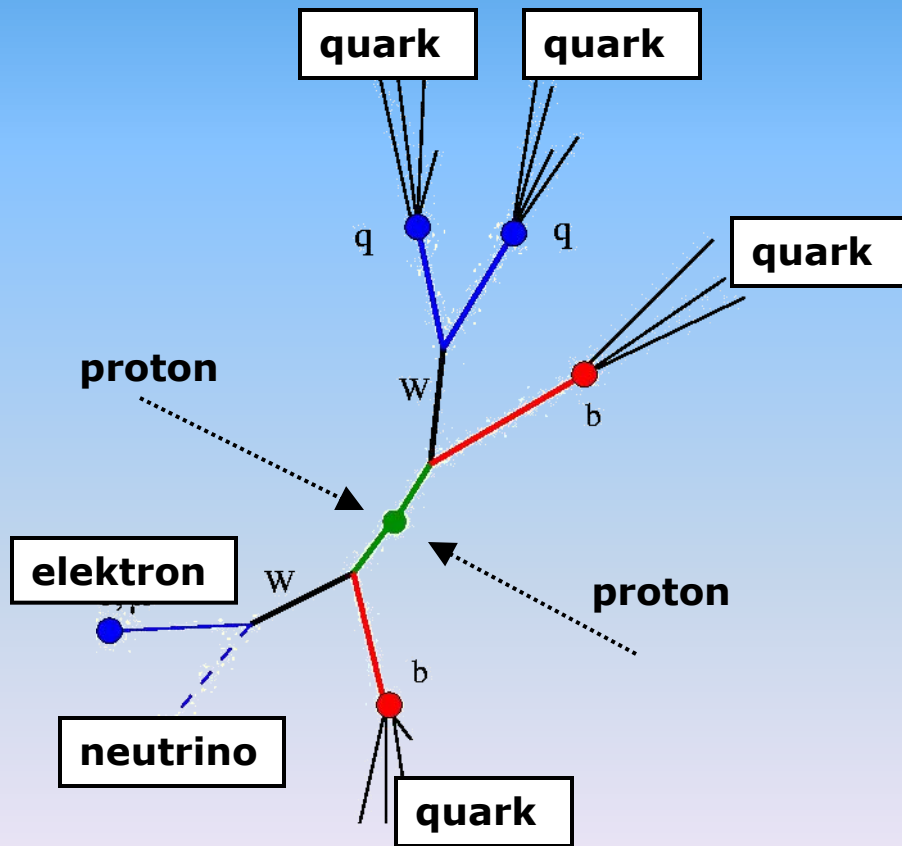

Simulatie top quark productie

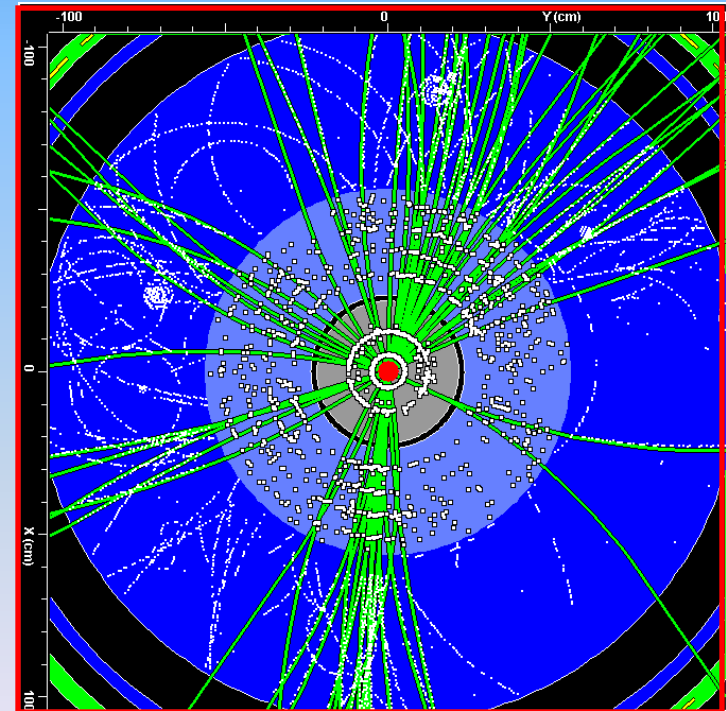

De Atlas detector

het grootste fototoestel op aarde

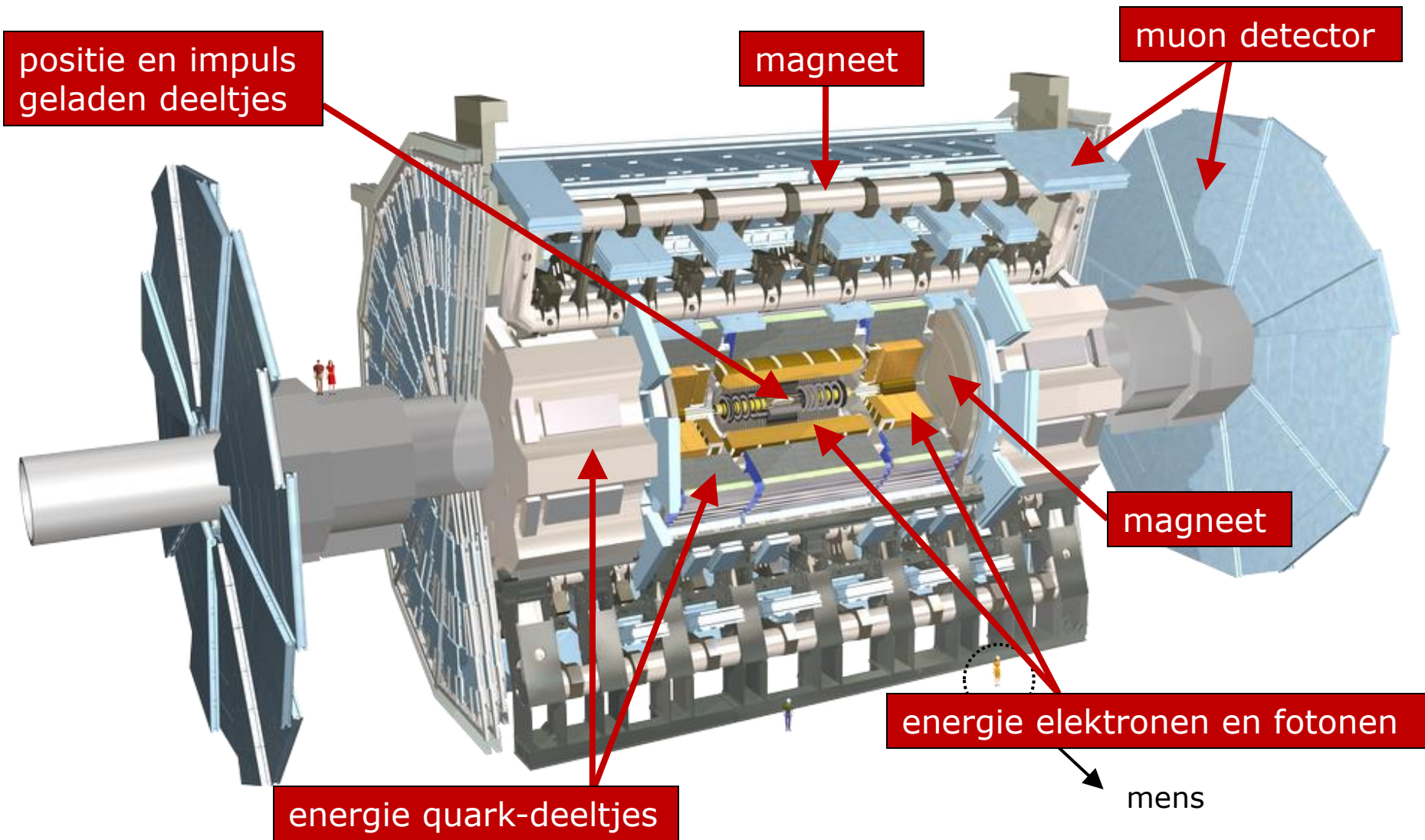

De Atlas pixel detector

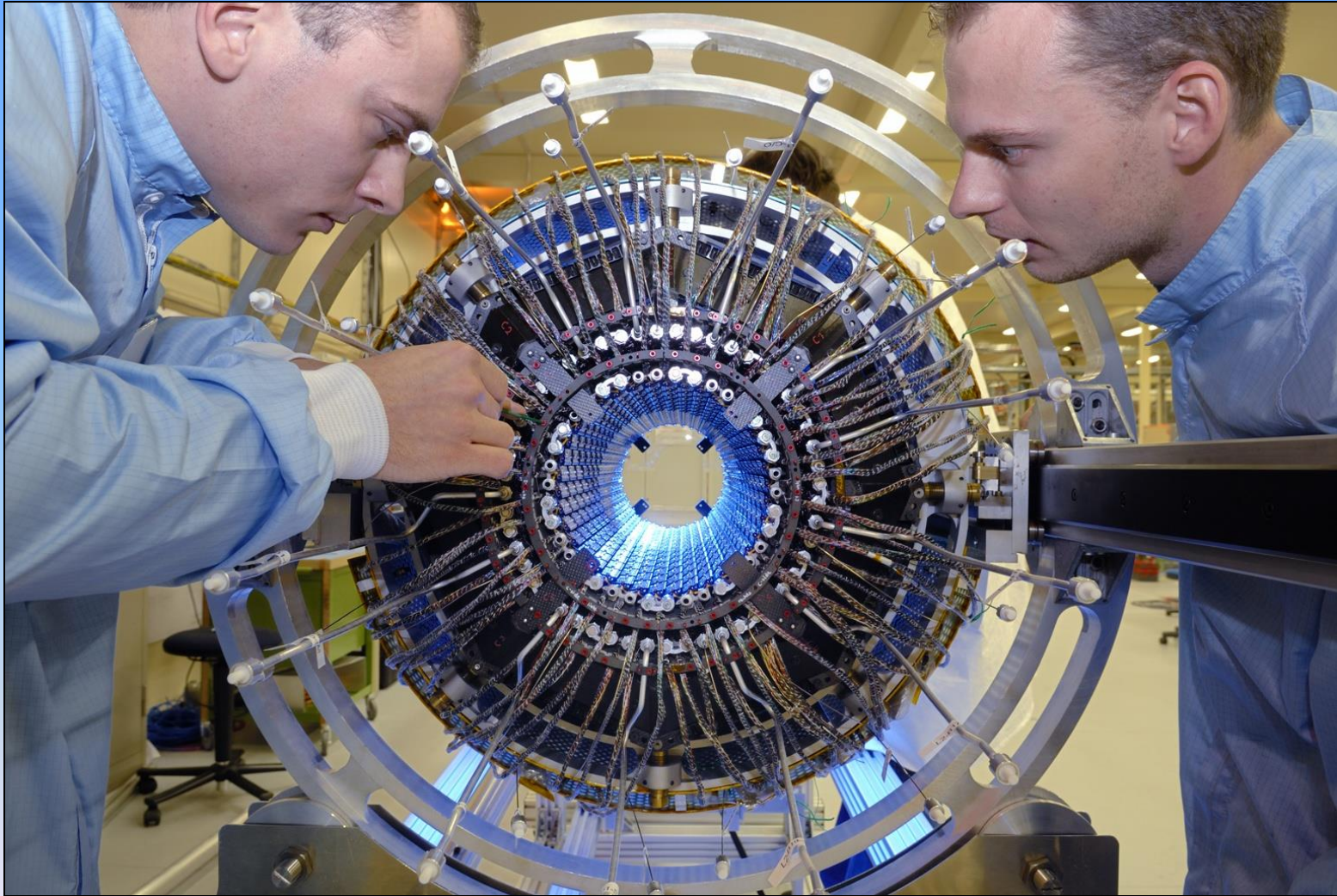

80 MegaPixel camera 40.000.000 foto's per seconde

The Atlas Muon Detector

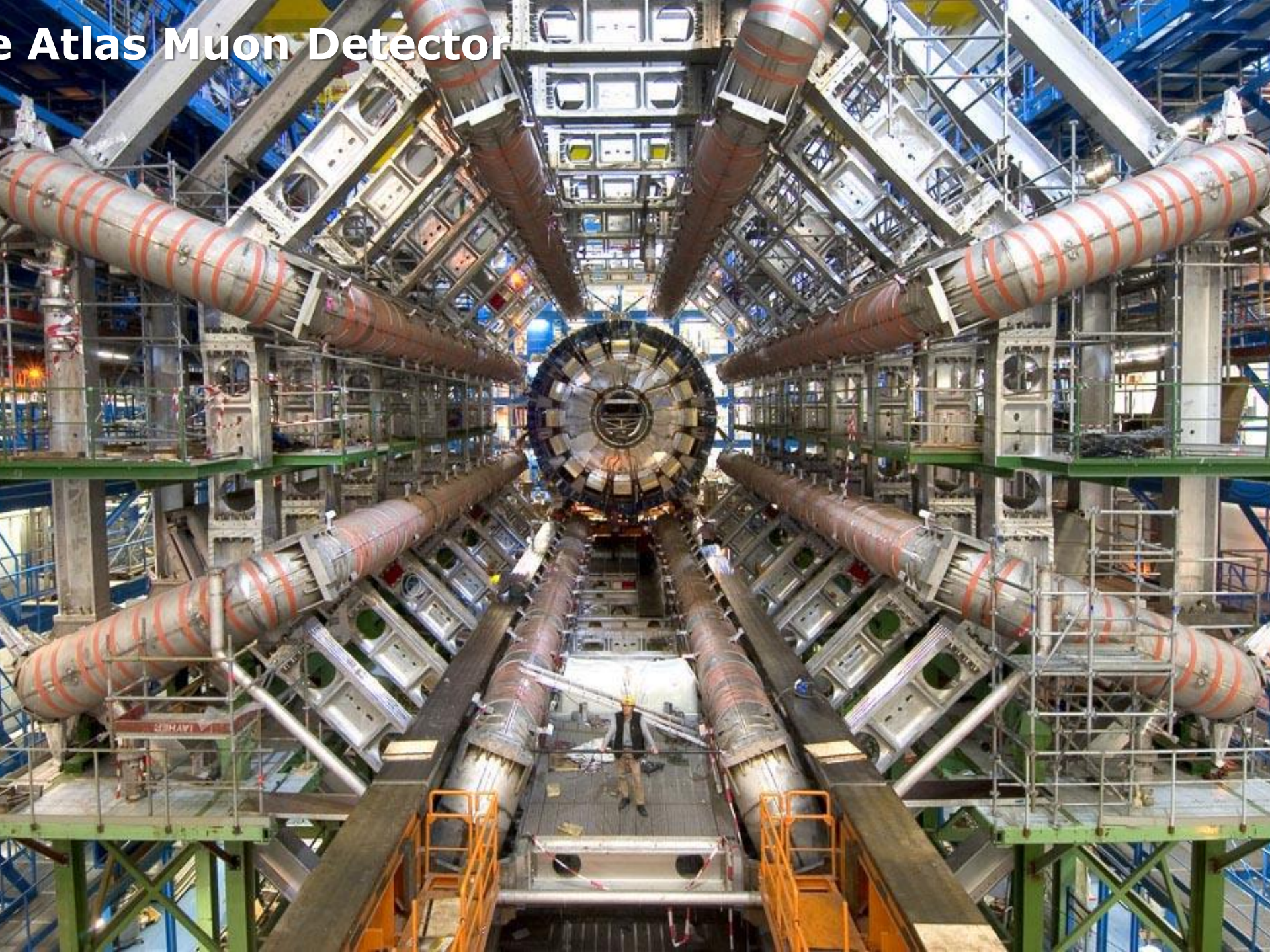

Konijn, auto of mens ?



Hoe ontdek je nieuwe dingen?

Nieuwe afstandschaal EN nieuwe detector

Nieuw ?

muon

muon

muon

muon

?

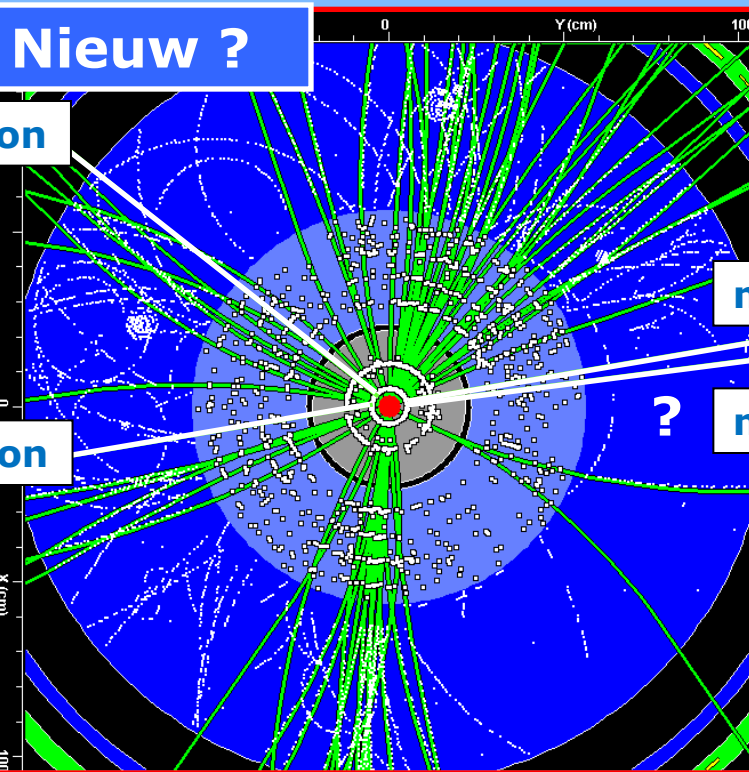

Normaal

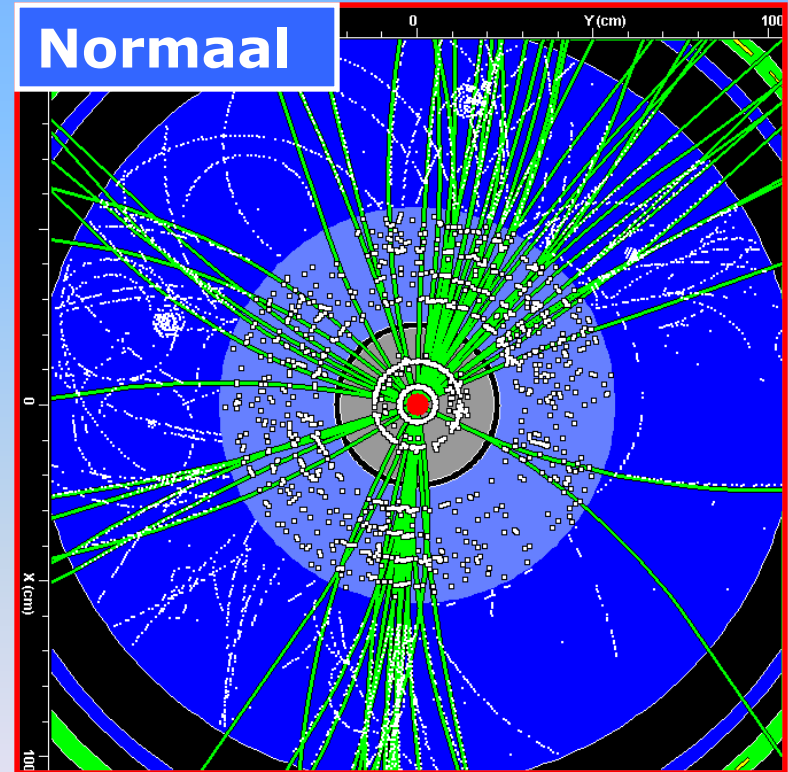

'foto' van een echte botsing

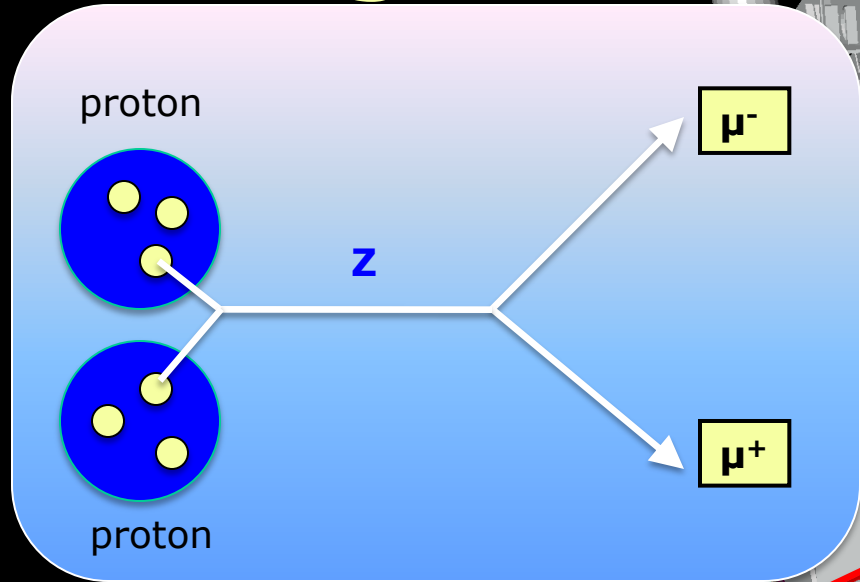
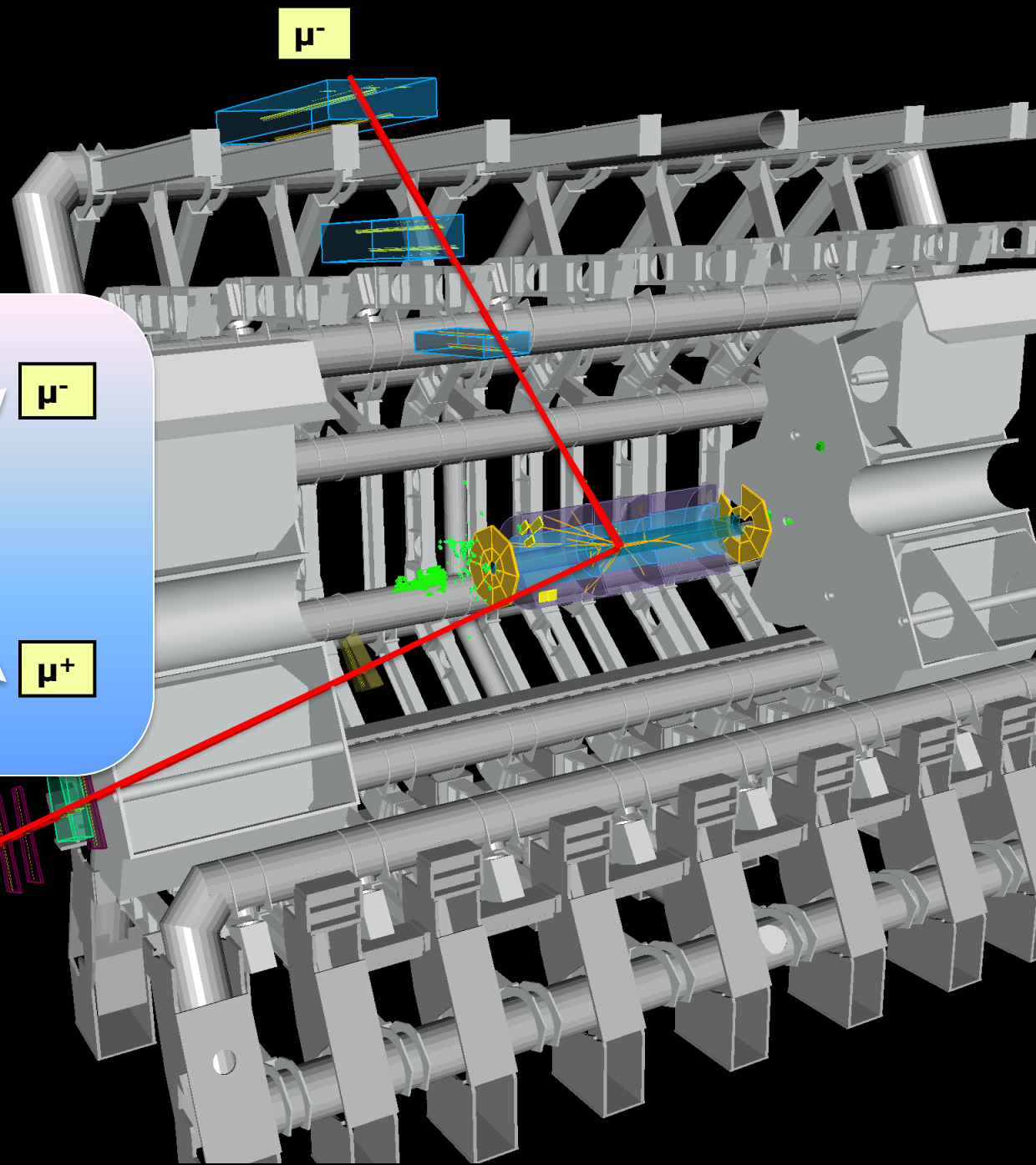

μ^+

μ^-

μ^+

μ^-

De ontdekking



PAUZE

De ontdekking



Hoe maak je deeltjes?

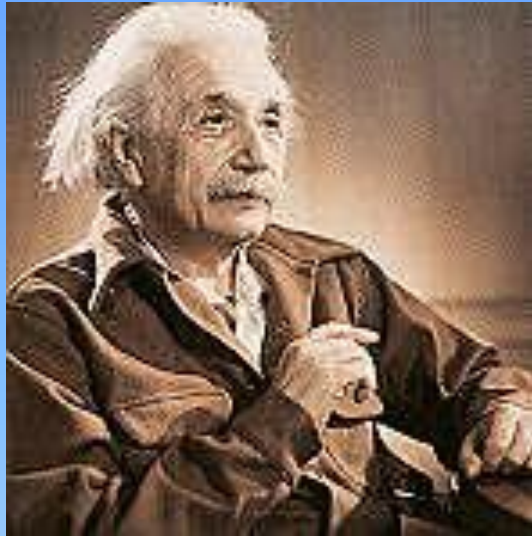

Albert Einstein:
 $E=mc^2$

materie + antimaterie = licht !
(en vice versa)

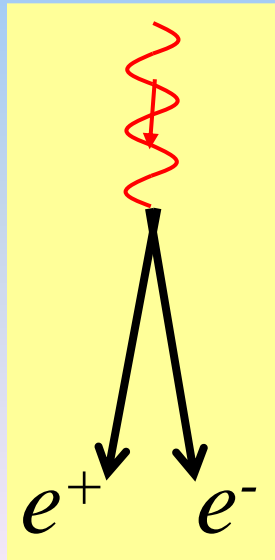
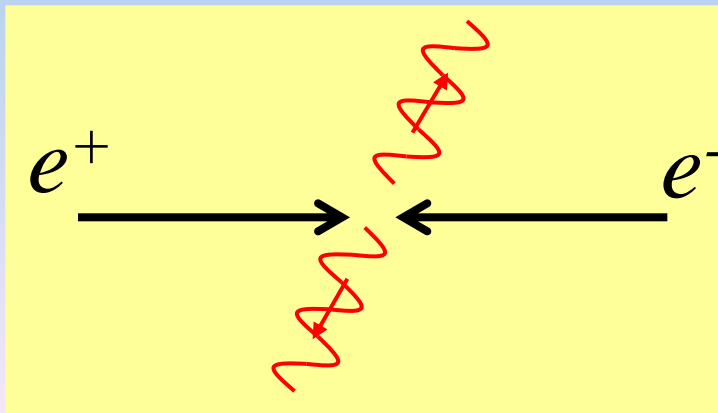

Hoe maak je een Higgs deeltje?

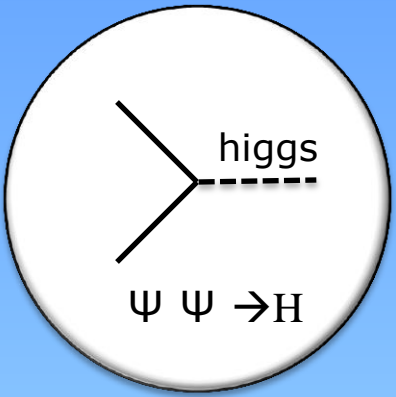

$\psi \psi H$



$$\mathcal{L} = -\frac{1}{4} F_{\mu\nu} F^{\mu\nu} + i\bar{\psi} \not{D} \psi + h.c. + \chi_i y_{ij} \chi_j \phi + h.c. + |D_\mu \phi|^2 - V(\phi)$$

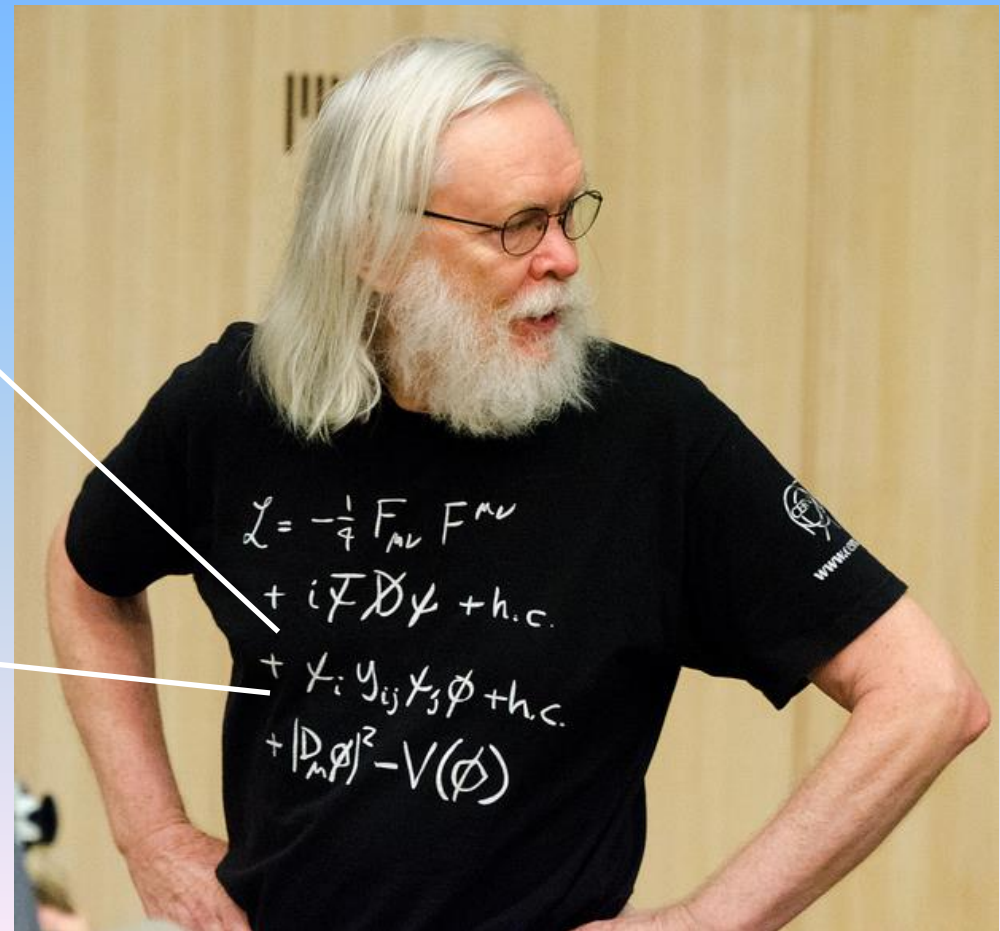

Hoe "zie" je een Higgs deeltje?

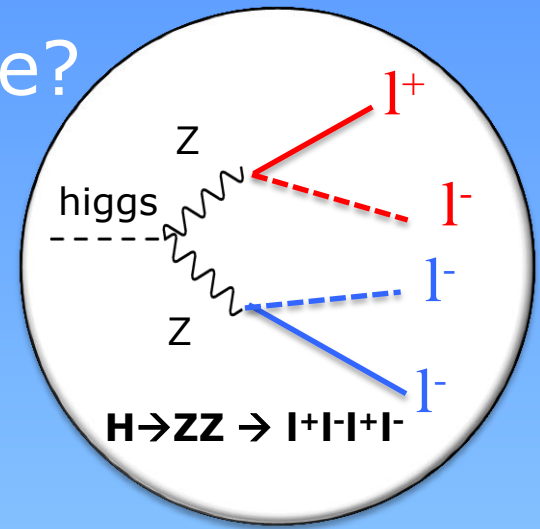

Higgs \rightarrow ZZ \rightarrow 4 leptonen

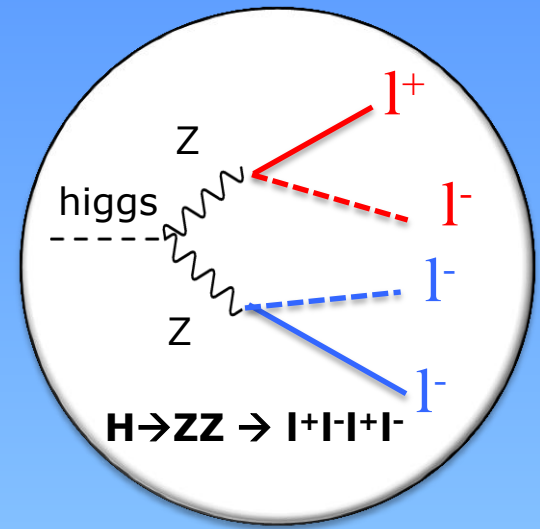
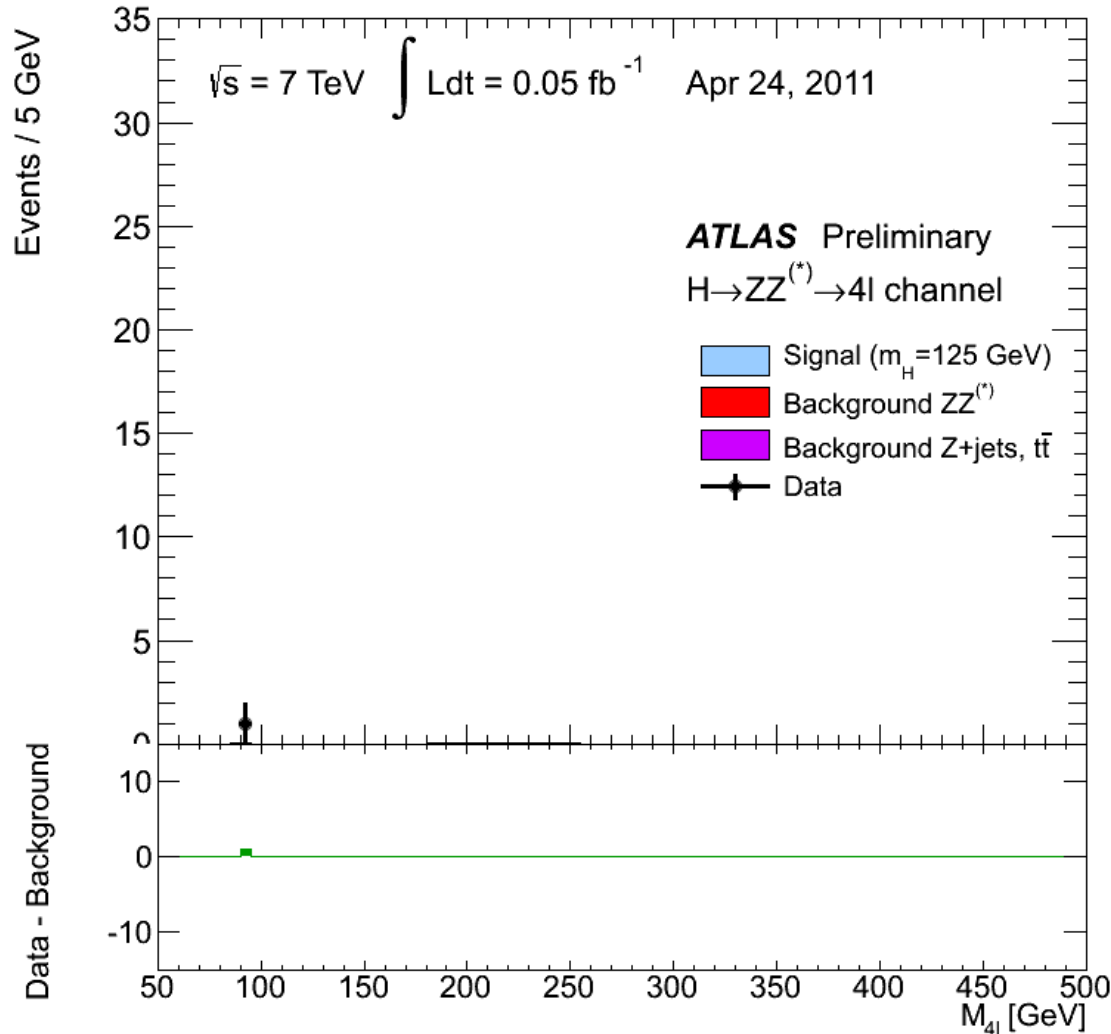

Klopt de **meting** met de **voorspelling** uit de computer?

Higgs \rightarrow ZZ \rightarrow 4 leptonen

klein aantal schitterende botsingen

120.000 Higgs bosonen



Maar 1 op de 1000 Higgs bosonen vervalt naar 4 leptonen

50% kans dat ATLAS detector ze allemaal goed terugvindt



60 Higgs \rightarrow 4 lepton events

'overig'	52 events
Met Higgs	68 events

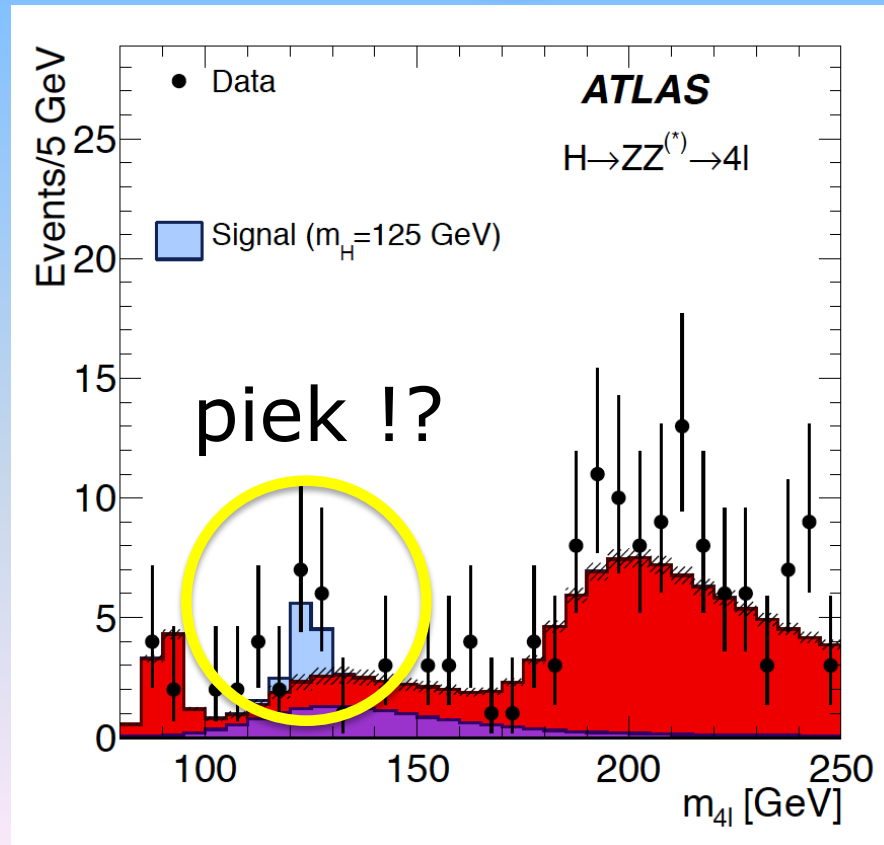
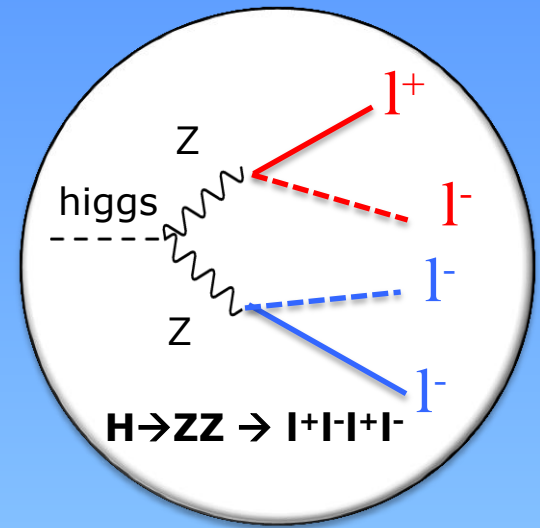

Higgs \rightarrow 2 fotonen

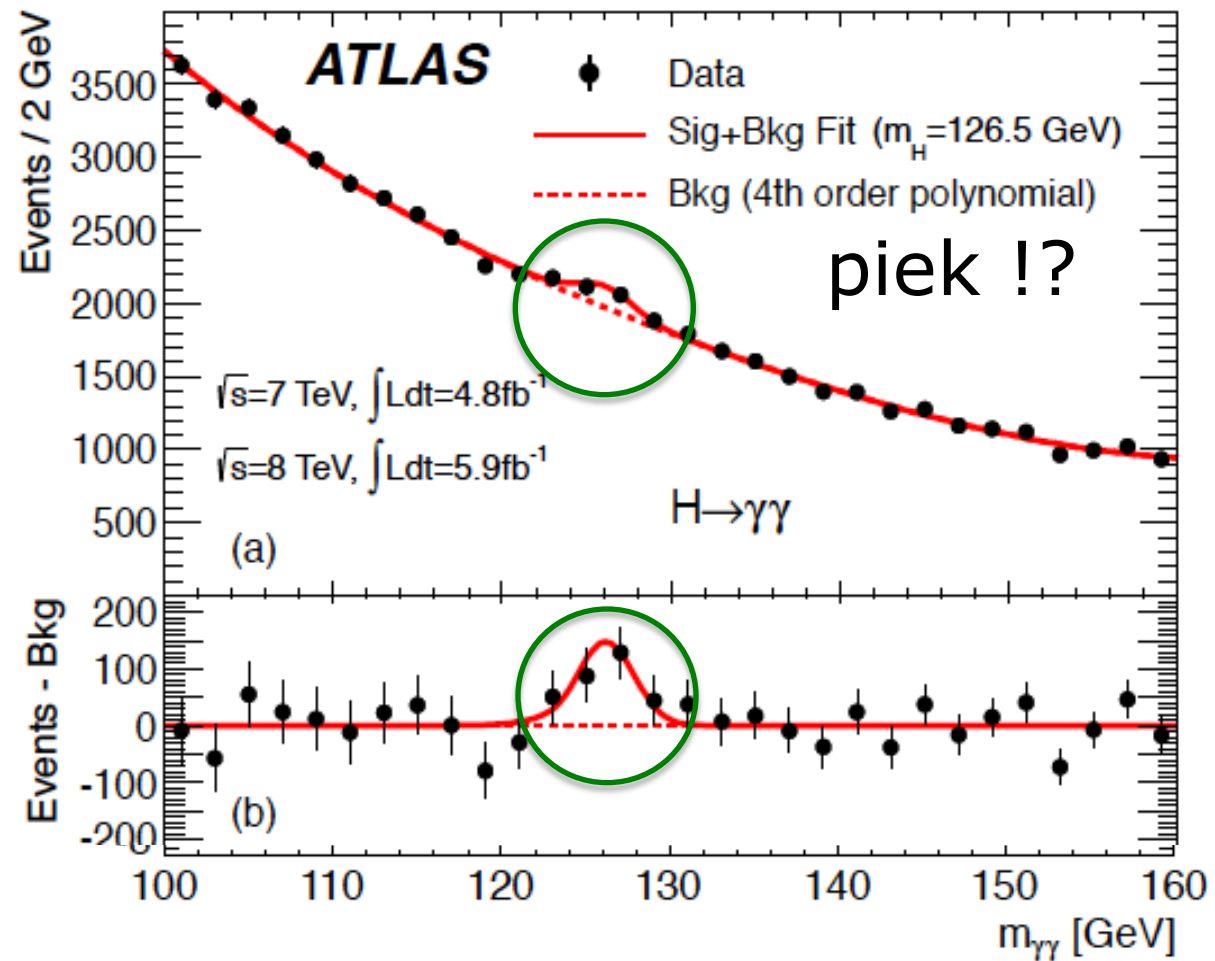
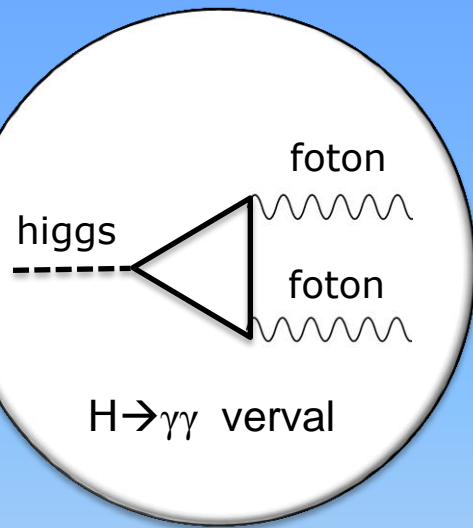

Interpretatie overschot in ATLAS



Claim pas ontdekking als:

Kans op toevallige fluctuatie zoals geobserveerd kleiner dan 1 op 1 miljoen

8 keer 6 gooien achter elkaar

Een ontdekking in slow-motion

Time-line higgs ontdekking

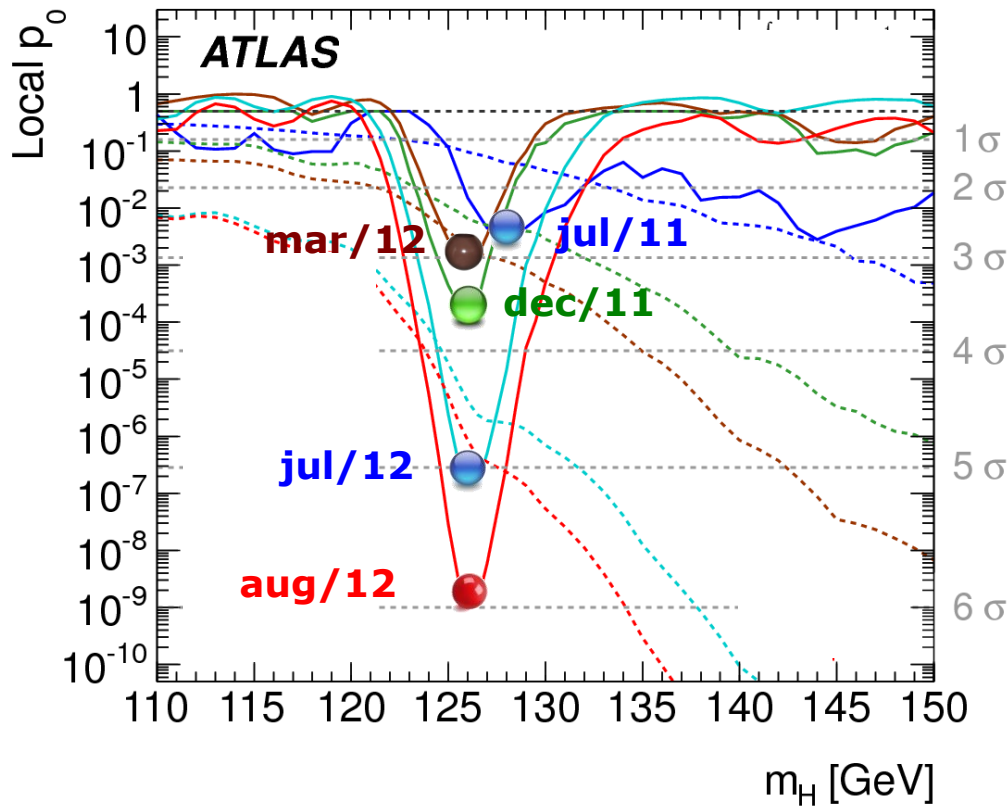

EUROPEAN ORGANISATION FOR NUCLEAR RESEARCH (CERN)



CERN-PH-EP-2012-218
Accepted by: Physics Letters B

Observation of a New Particle in the Search for the Standard Model Higgs Boson with the ATLAS Detector at the LHC

The ATLAS Collaboration

This paper is dedicated to the memory of our ATLAS colleagues who did not live to see the full impact and significance of their contributions to the experiment.

Abstract

A search for the Standard Model Higgs boson in proton-proton collisions with the ATLAS detector at the LHC is presented. The datasets used correspond to integrated luminosities of approximately 4.8 fb^{-1} collected at $\sqrt{s} = 7 \text{ TeV}$ in 2011 and 5.8 fb^{-1} at $\sqrt{s} = 8 \text{ TeV}$ in 2012. Individual searches in the channels $H \rightarrow ZZ^{(0)} \rightarrow 4\ell$, $H \rightarrow \gamma\gamma$ and $H \rightarrow WW^{(0)} \rightarrow \ell\nu\ell\nu$ in the 8 TeV data are combined with previously published results of searches for $H \rightarrow ZZ^{(0)}$, $WW^{(0)}$, $b\bar{b}$ and $\tau^+\tau^-$ in the 7 TeV data and results from improved analyses of the $H \rightarrow ZZ^{(0)} \rightarrow 4\ell$ and $H \rightarrow \gamma\gamma$ channels in the 7 TeV data. Clear evidence for the production of a neutral boson with a measured mass of $126.0 \pm 0.4 (\text{stat}) \pm 0.4 (\text{sys}) \text{ GeV}$ is presented. This observation, which has a significance of 5.9 standard deviations, corresponding to a background fluctuation probability of 1.7×10^{-4} , is compatible with the production and decay of the Standard Model Higgs boson.

arXiv:1207.7214v2 [hep-ex] 31 Aug 2012

Ontdekking van het Higgs deeltje op 4 juli 2012

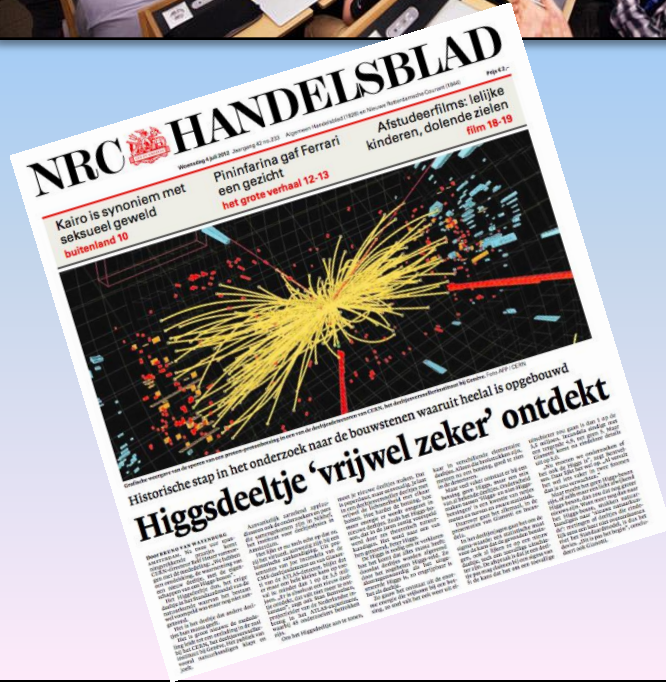

Waarom is de Higgs zo bijzonder?

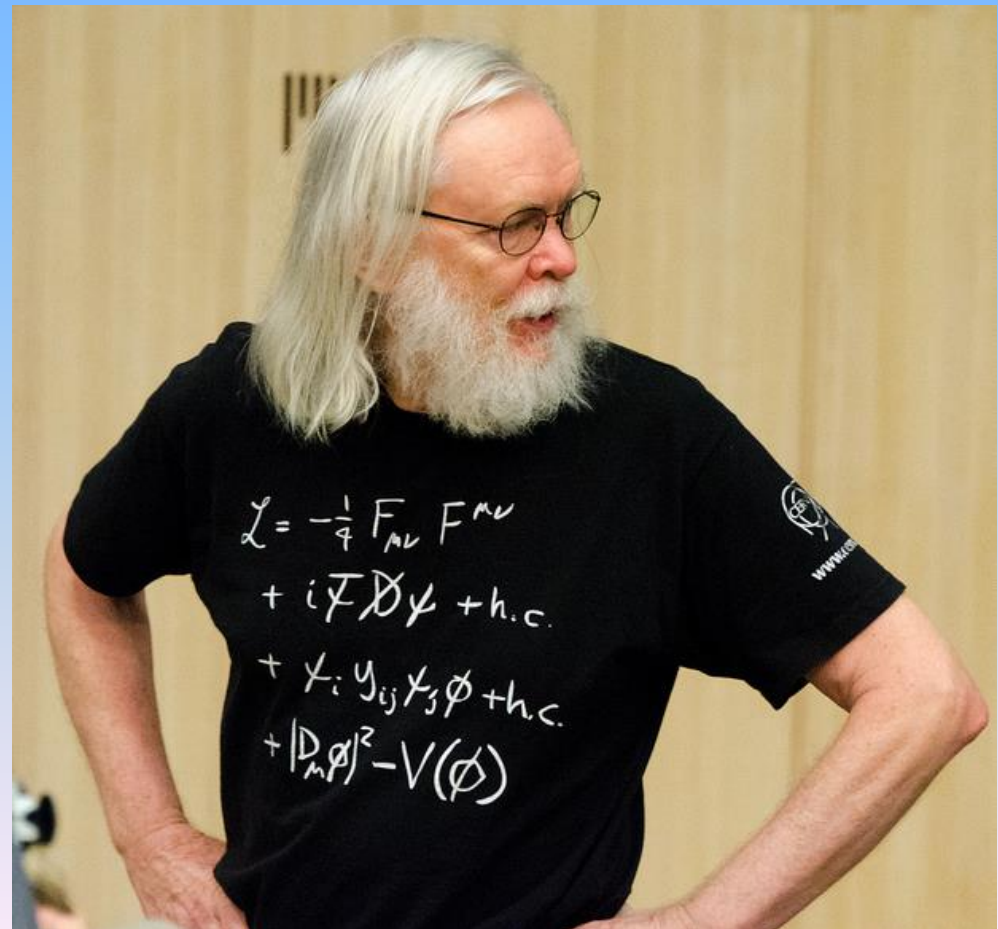

Waarom is de Higgs zo bijzonder?

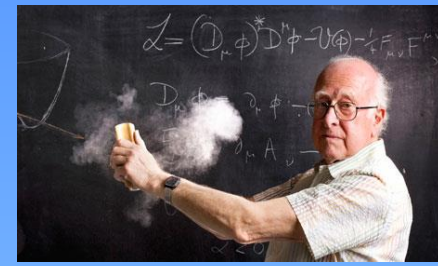

Higgs heeft unieke rol in de wereld van elementaire deeltjes

ψ : "normale" deeltjes

ϕ : Higgs

De helft van het T-shirt gaat over Higgs!

$$\begin{aligned} \mathcal{L} = & -\frac{1}{4} F_{\mu\nu} F^{\mu\nu} \\ & + i \bar{\psi} \not{D} \psi \\ & + \sum_i y_{ij} \bar{\psi}_i \psi_j \phi \\ & + |D_\mu \phi|^2 - V(\phi) \end{aligned}$$

Quarks	u up	c charm	t top
	d down	s strange	b bottom
Leptons	ν_e electron neutrino	ν_μ muon neutrino	ν_τ tau neutrino
	e electron	μ muon	τ tau

γ photon	Force carriers
Z Z boson	
W W boson	
g gluon	

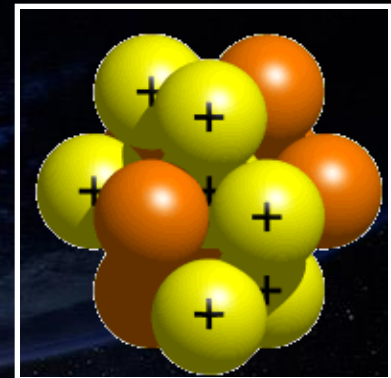
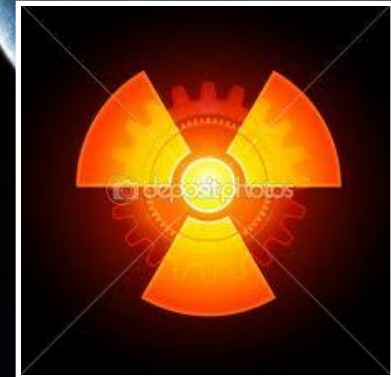

12 deeltjes

4 krachten

+ Higgs



Waarom is de Higgs zo bijzonder?

Deeltje

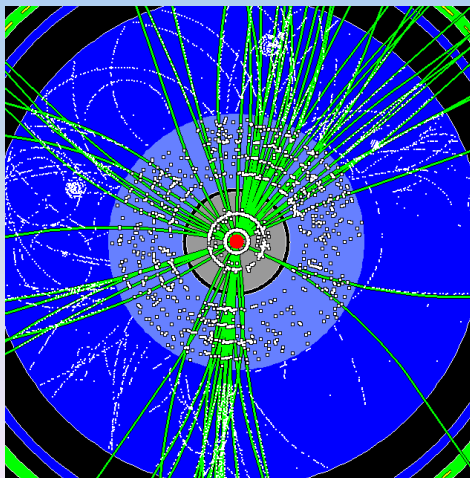
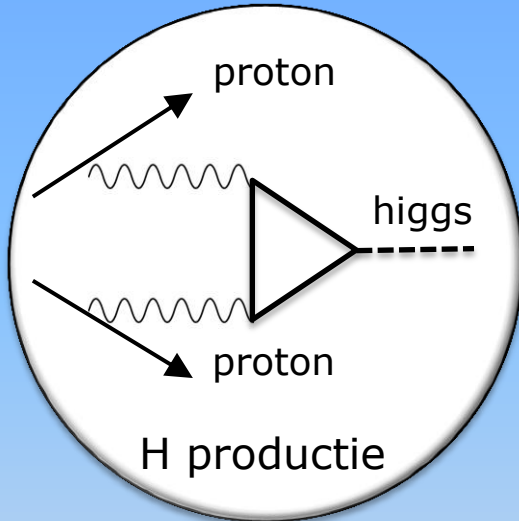

Veld

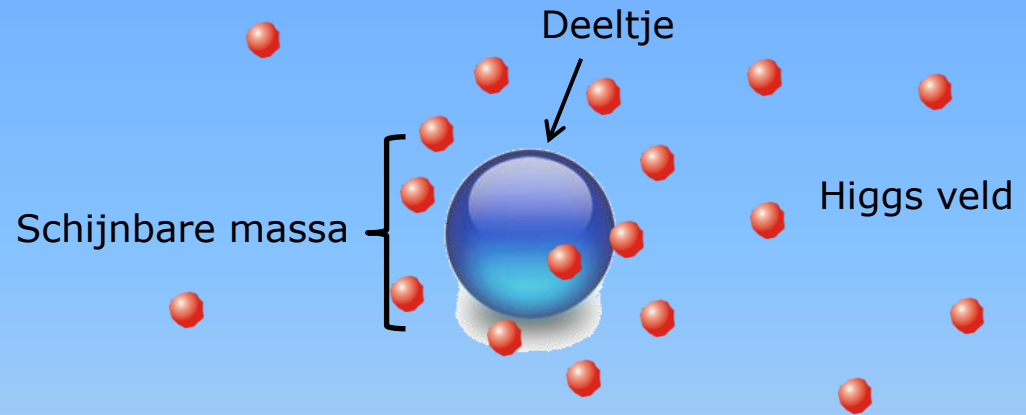

Alsof de vis het water heeft ontdekt...

Deeltje? Veld?

Deeltje

Foton (lichtdeeltje)

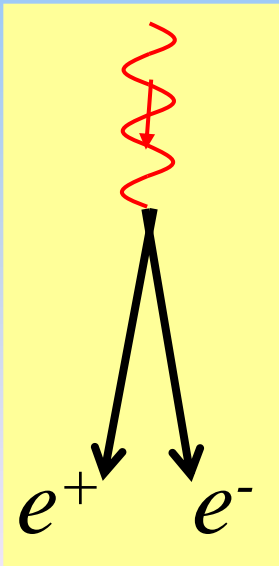

Veld

Elektrisch veld



Het Higgs veld – kun je het zien?

Het Higgs veld is uniform – als het meer in deze foto

Het maken van een Higgs deeltje is als een rimpeling op het meer

De theorie van Higgs:

als het veld bestaat is er
ook een bijbehorend deeltje



Wat is massa ?? Anno 1964

Massa van elementaire deeltjes komt door
"wrijving" met alomtegenwoordig 'Higgs veld'

$$m: \psi\psi H$$

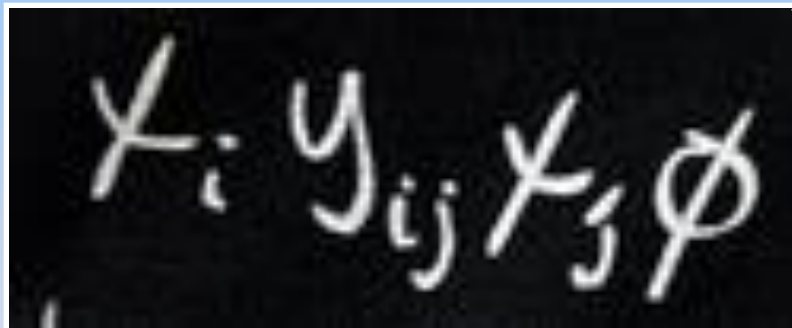

$$\mathcal{L} = -\frac{1}{4} F_{\mu\nu} F^{\mu\nu} + i\bar{\psi}\not{D}\psi + h.c. + \chi_i y_{ij} \chi_j \phi + h.c. + |D_\mu \phi|^2 - V(\phi)$$

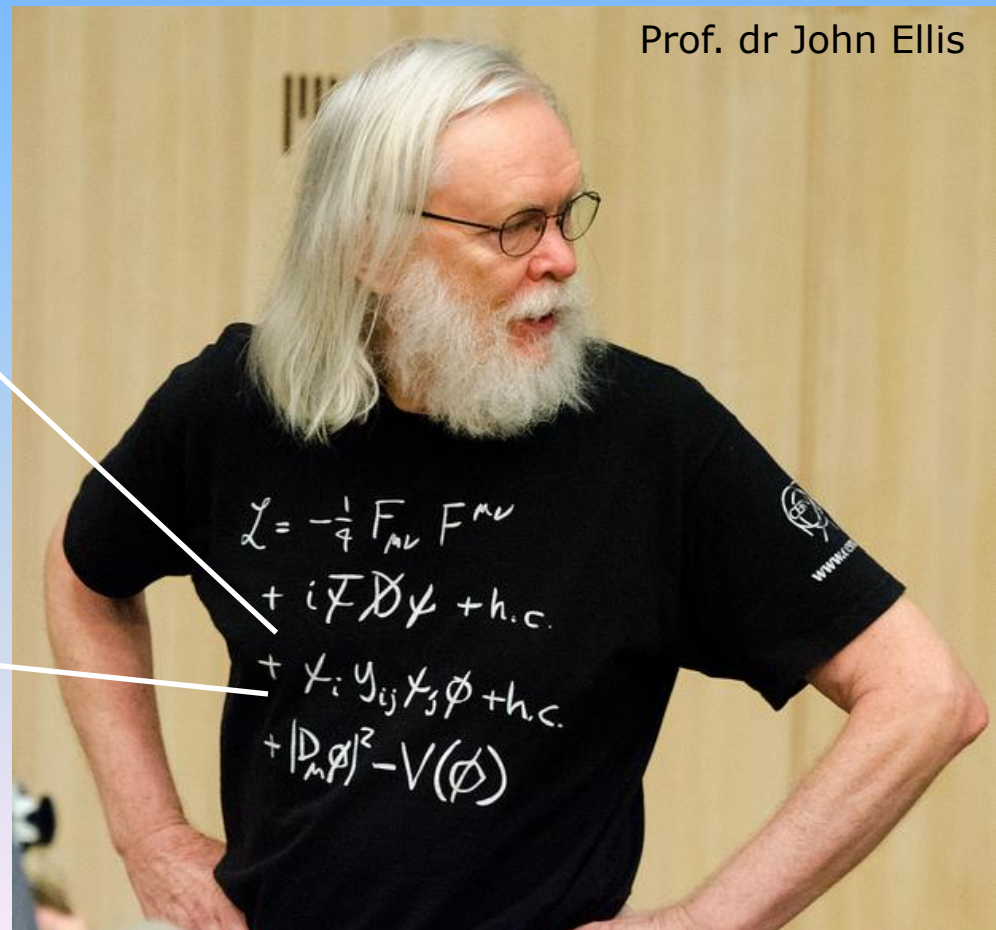

Wat is massa ?

Massa van elementaire deeltjes komt door

“wrijving” met alomtegenwoordig ‘Higgs veld’

Einstein:

proton massa =
bindings energie

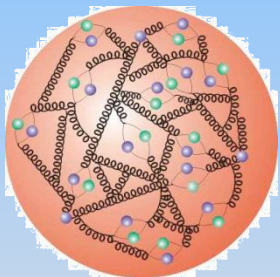

Elementair deeltje
in lege ruimte:
geen rust-energie=
geen massa



Elementair deeltje
in Higgs veld:
rust energie =
interactie met Higgs veld
= massa

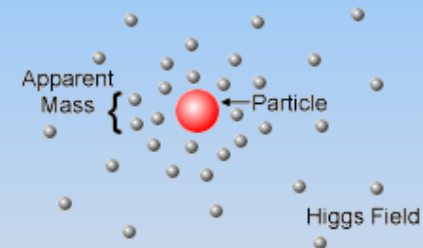

Revolutionair – met spectaculaire consequenties :

de ruimte is *niet* leeg, maar gevuld met soort ‘ether’

Als de marslander
leven vindt ...

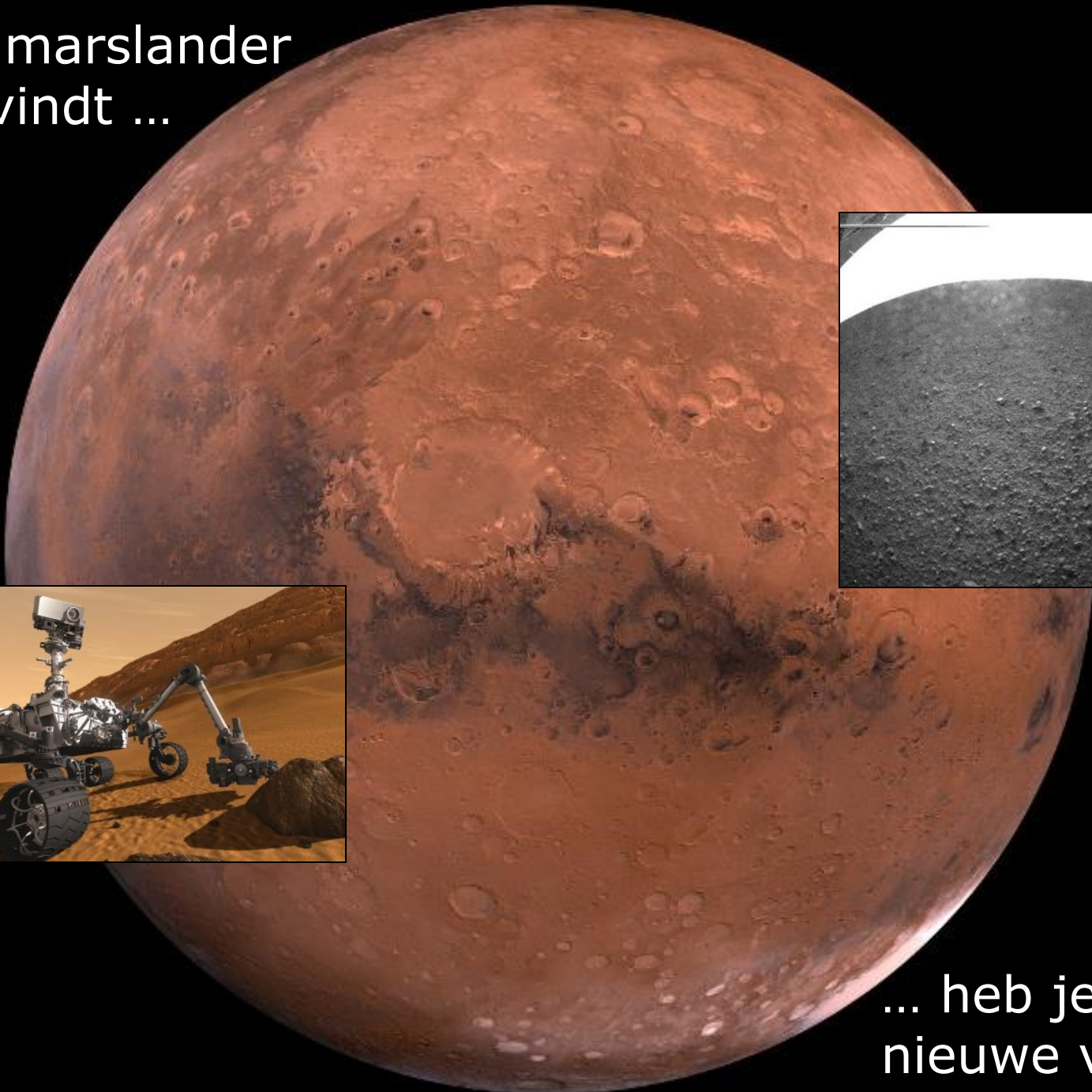

... heb je 1000
nieuwe vragen

Kloppen Higgs' eigenschappen ?

$m_h = 125 \text{ GeV}$

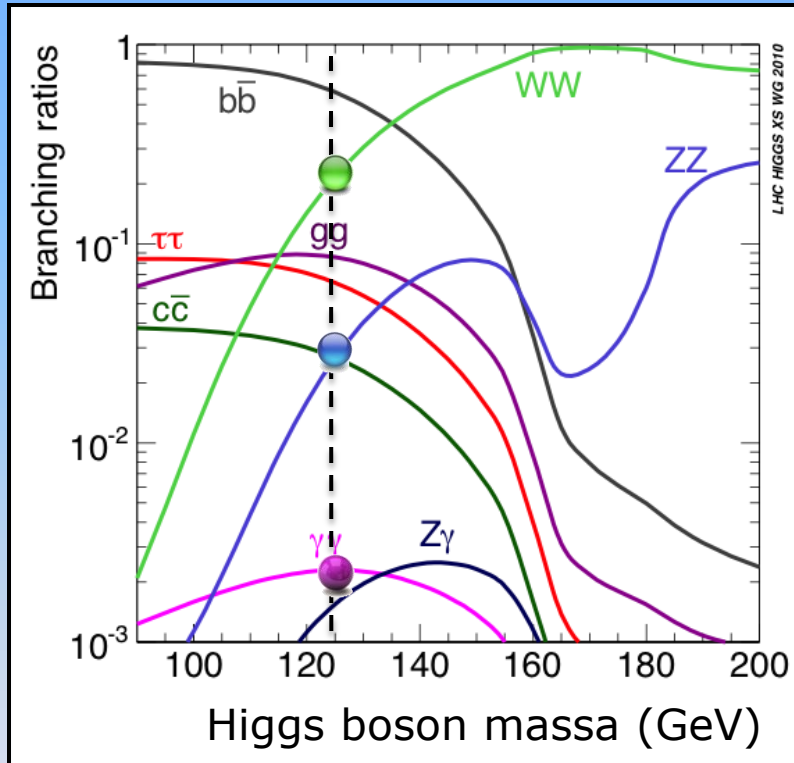

voorspelling

Standaard Model

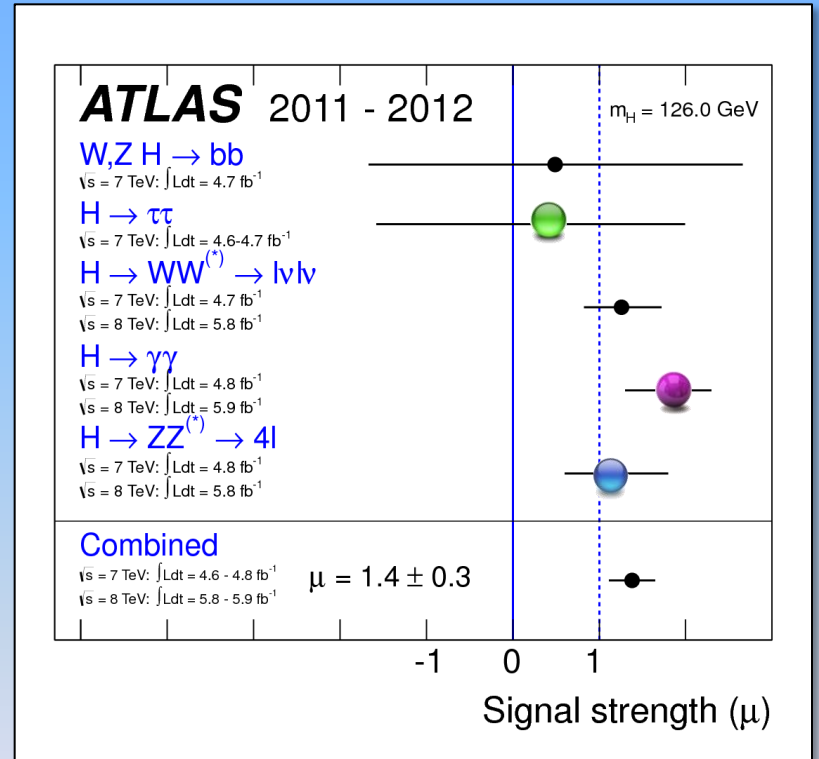

meting

Kloppen Higgs' eigenschappen ?

Zijn er nog meer soorten Higgs deeltjes ?

$$\begin{aligned}\mathcal{L}_{\text{susy}} = & -\frac{g^2}{8} (H_u^\dagger \sigma^a H_u + H_d^\dagger \sigma^a H_d)^2 - \frac{g'^2}{8} (H_u^\dagger H_u - H_d^\dagger H_d)^2 \\ & + \lambda_{ij}^u H_u^T \epsilon \bar{u}_i q_j - \lambda_{ij}^d H_d^T \epsilon \bar{d}_i q_j - \lambda_{ij}^e H_e^T \epsilon \bar{e}_i \ell_j \\ & - \frac{H_u^\dagger}{\sqrt{2}} (g \sigma^a \bar{W}^a + g' \bar{B}) \bar{H}_u - \frac{H_d^\dagger}{\sqrt{2}} (g \sigma^a \bar{W}^a - g' \bar{B}) \bar{H}_d + \text{h.c.}\end{aligned}$$

Een stap verder...



Een ander veld: de Big Bang

Een van Higgs' eigenschappen komt overeen met een ander veld...

Het *inflaton* dat de het heelal opblies tussen 10^{-33} en 10^{-32} seconde na de Big Bang

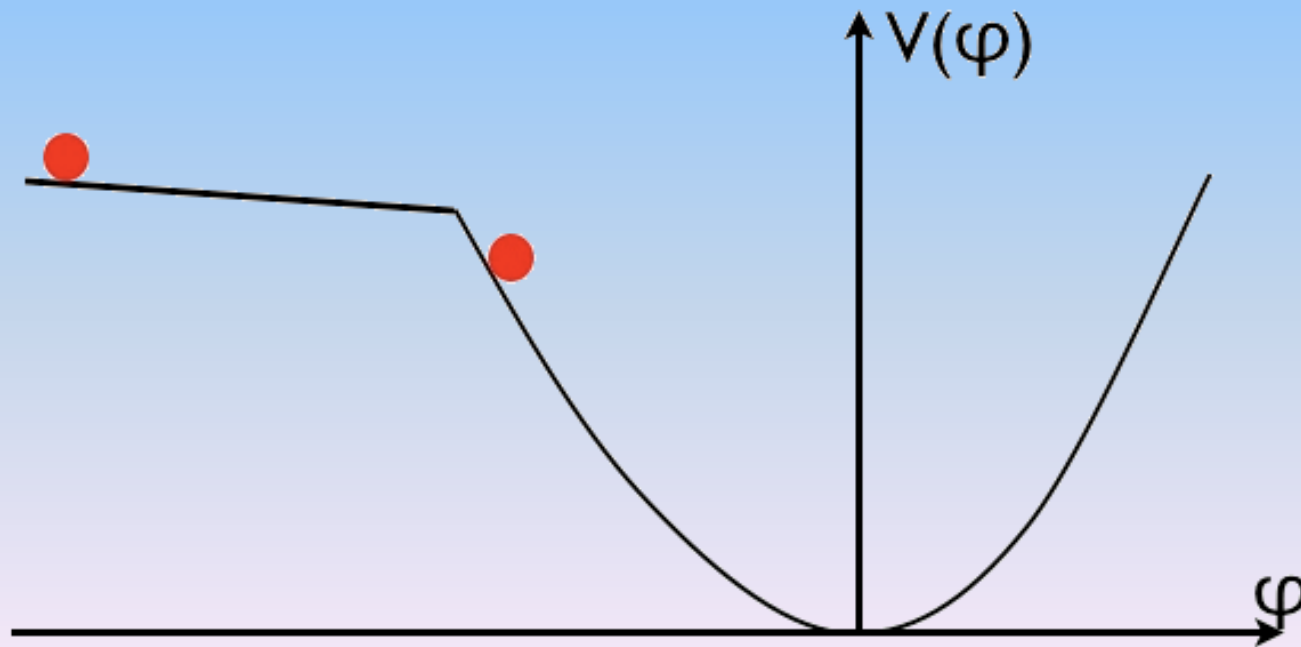

Een ander veld: de Big Bang

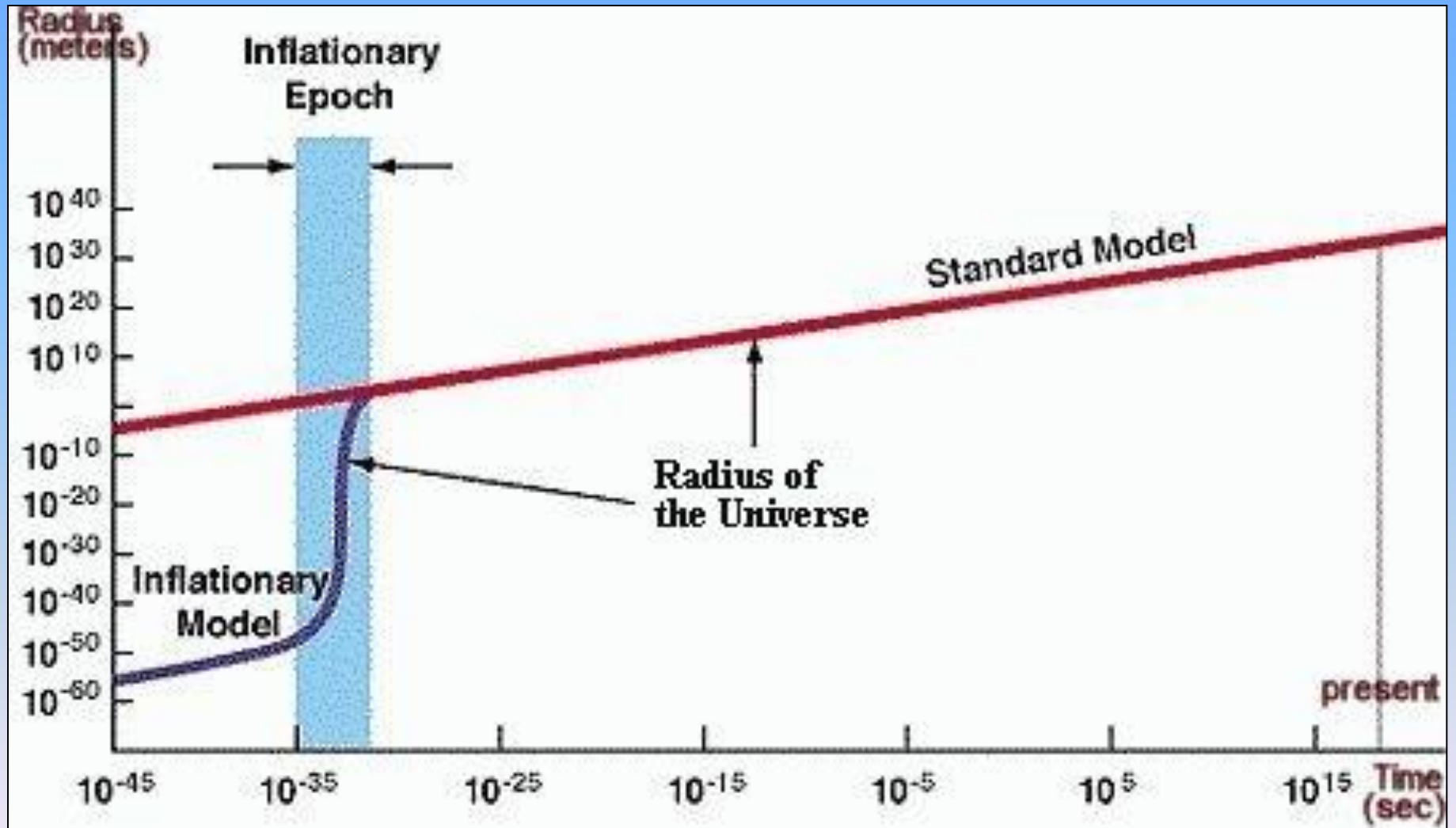

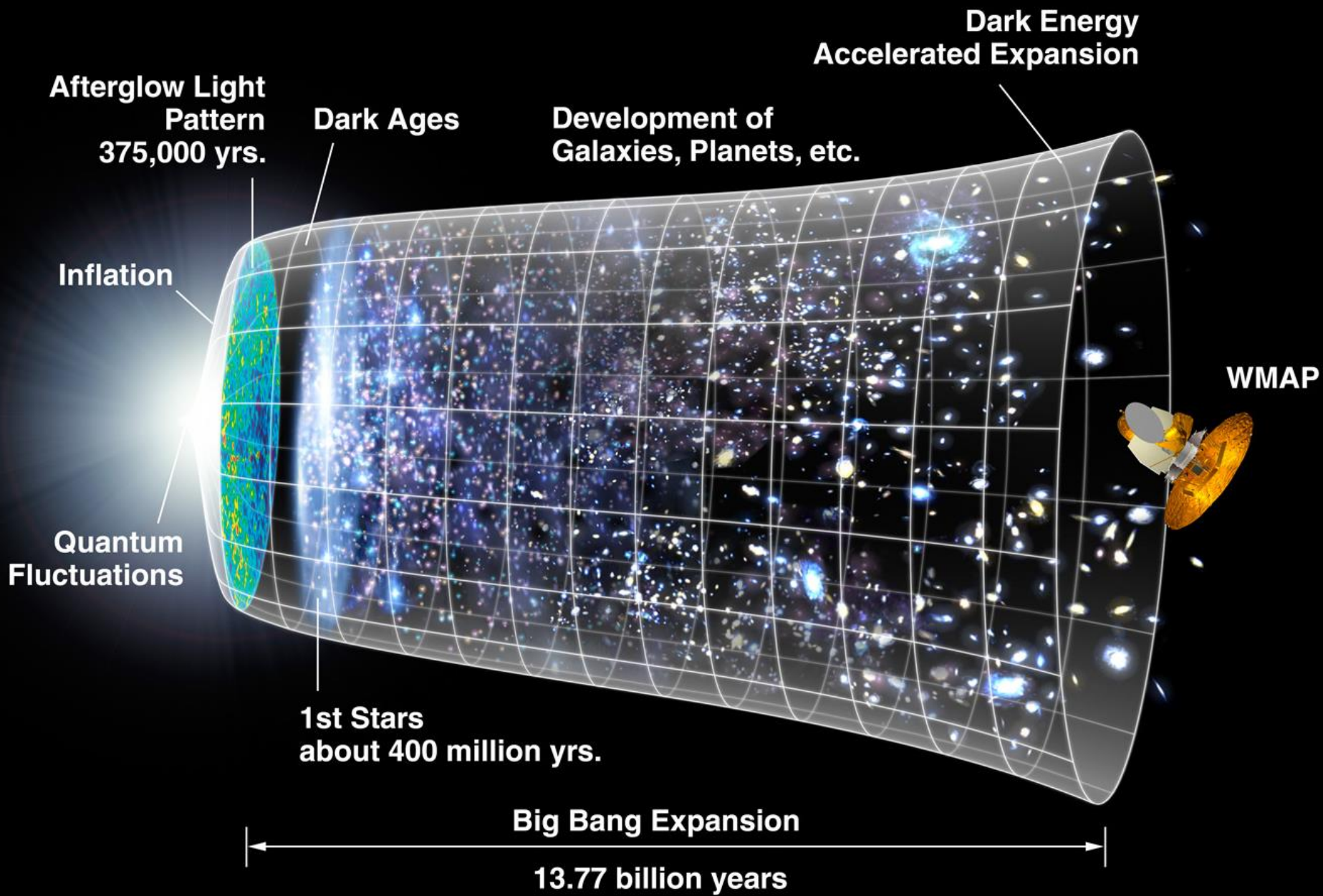

Higgs:

1

Een Higgs deeltje gevonden in Geneve

2

Heelal gevuld met Higgs veld

3

Kloppen zijn eigenschappen?

Nog een paar 'kleine' dingetjes:

4

80% van de materie in het heelal is onbekend
→ donkere materie

5

Waar is alle anti-materie gebleven ?

6

Higgs boson (hoe krijgen deeltjes massa) ?

- waarom past gravitatie niet in SM, extra dimensies, waarom 3 families, fermionen fundamentele deeltjes, supersymmetrie, protonen stabiel, kwantisatie elektrische lading, exploderende quantumcorrecties, kleine neutrino massa's, string theorie, ...

EINDE