

The construction of a microstrip gas tracker for HERMES

J. van den Brand, H.J. Bulten, J. Blouw, M. Doets, F.G. Hartjes, T. Henkes, E. Kok, M. Kraan,
J.J. Niessink, J. Rövekamp, J. Schippers and F. Udo
NIKHEF, Amsterdam, The Netherlands

R. Horisberger
PSI, Villigen, Switzerland

November 1994

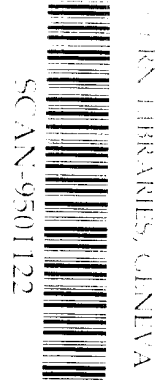

Sw 9503

*Talk given at the International Workshop on Microstrip Gas Chambers, Legnaro (Italy), 13 - 14
October 1994*

The construction of a microstrip gas tracker for HERMES

J. van den Brand, H.J. Bulten, J. Blouw, M. Doets, F.G. Hartjes, T. Henkes, E. Kok, M. Kraan, J.J. Niessink, J. Rövekamp, J. Schippers and F. Udo
NIKHEF, Amsterdam, The Netherlands

R. Horisberger
PSI, Villigen, Switzerland

INTRODUCTION

To measure the spin structure of the nucleon, the HERMES[1] experiment is planned at the HERA electron beam using a polarised internal gas target. A tracker is being built to reconstruct the vertex of the exiting particles. It consists of two drift chambers and two microstrip gas counter (MSGC) systems.

The MSGC systems are housed into two gas gastight containers surrounding the beam pipe and located immediately after the exit flange of the target housing (fig. 1.). The active area of the upper MSGC system covers an angular range of $40 \text{ mrad} \leq \theta_v \leq 140 \text{ mrad}$ by $-170 \text{ mrad} \leq \theta_h \leq 170 \text{ mrad}$. Below the beam pipe a second system is situated with the same acceptance. Each track within the acceptance is measured by two stations of three MSGCs having a strip orientation of 0° , and $+30^\circ$ and -30° respectively with respect to the vertical axis.

MSGC PARAMETERS

Assembly

The design of the HERMES tracker is schematically shown in fig. 1. Each station consists of three planes having a different strip orientation with respect to the vertical. As a result, three different types of MSGCs are used (table 1.). They are all built from one or more PC boards onto which the substrates are glued. Since MSGC substrates of this size are not easily produced, at least three substrates had to be used to cover the full acceptance area. The 0° MSGCs consist of 3 PC boards that are mounted under an angle of 120 mrad . The angle is introduced to keep the angle of incidence of the particle on the detector plane below 71 mrad , thus avoiding deterioration of the position resolution[2]. In every MSGC frame a semi circular cut-out has been made to keep the distance to the beam pipe as small as possible.

Table 1.

MSGC type	0° long	0° short	30°
sensitive area	$136.5 \times 395.1 \text{ mm}^2$	$136.5 \times 323.4 \text{ mm}^2$	$136.5 \times 405.9 \text{ mm}^2$
# of substr.	3	3	5
# of APCs	33	27	35
# of channels	2046	1674	2170

Substrates

The substrate consists of a thin plate of borosilicate glass covered by a thin resistive layer made of a nickel-chromium alloy and an aluminum layer (table 2). After completion of the photolithography, the substrate edges around the pattern are cut with a precision of $30 - 50 \mu\text{m}$. In this way in the

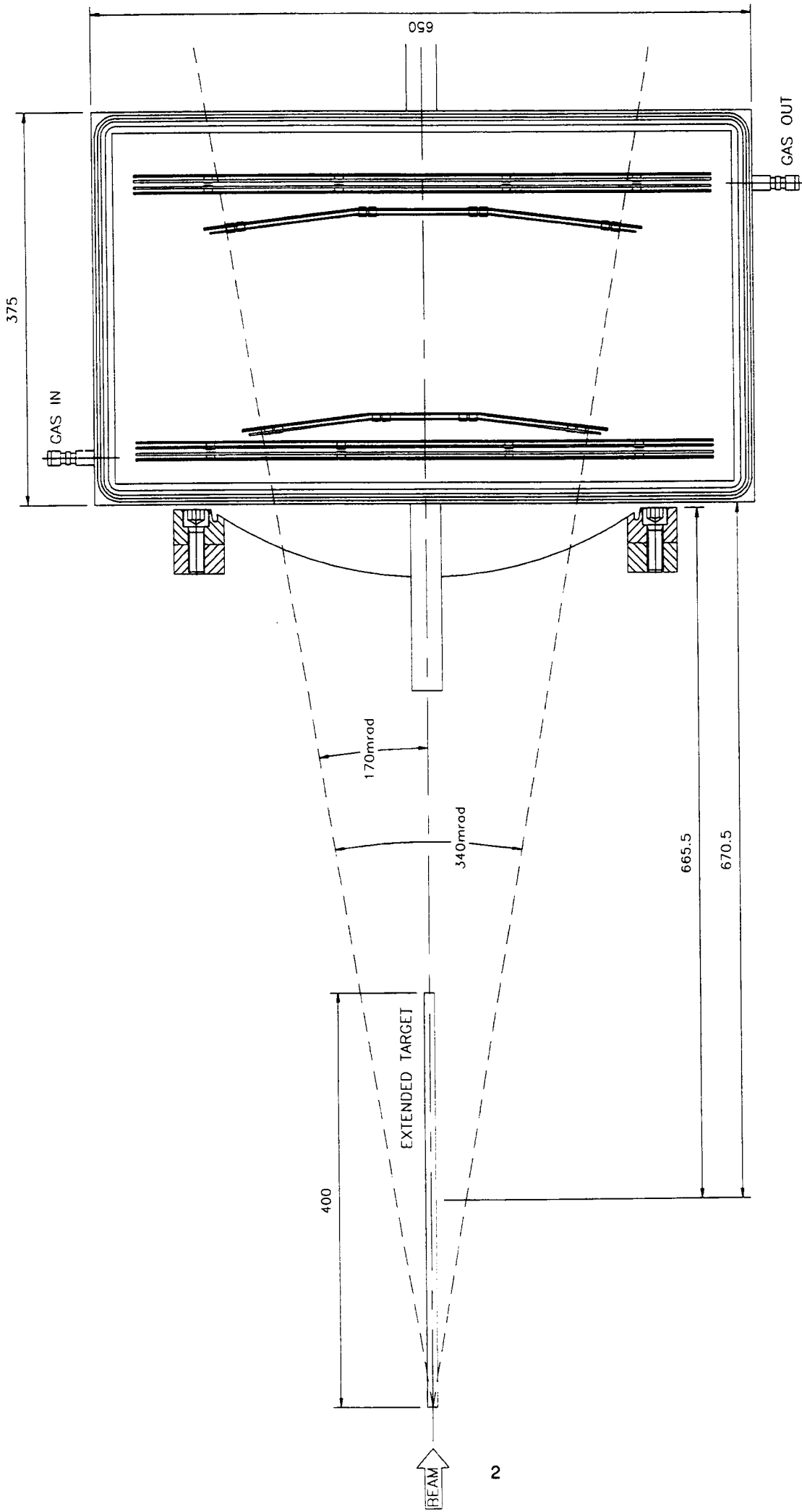

Fig. 1. Set-up of the HERMES MSGCs in the gas housing at the HERA beam area

transition region the centre to centre distance between the cathode strip of one substrate and that of the neighbouring substrate amounts to only 250 μm . The meander shaped 1 M Ω cathode resistors and the fan-in structure have been reduced to the minimal values of 2.38 and 2.75 mm respectively to minimize the dead area at small angles. The fan-in structure consists of 62 channels each, for electronic reasons the two remaining inputs of the APC 64 front end chip are not connected.

The substrate has been equipped with a circuit that protects the delicate strip structure and the preamps against micro-discharges. A 1 M Ω resistor that connects a group of 16 cathode strips to the HV supply, limits the electrical energy that is liberated at a discharge to 35 μJ . In addition to this, resistors of 1 k Ω that connect the anode to the preamp input, limit the peak current of the discharge to less than 0.5 A. They also absorb most of the electrical energy that otherwise would be deposited into the spark itself and the preamp input. The substrate parameters, listed in table 2, do not differ substantially from what is commonly used for MSGCs. The glass thickness of 200 μm is the minimal value that can be used for substrates of these dimensions to keep the deflection from the electrostatic forces within an acceptable level.

Table 2.

MSGC parameters	
substrate material	200 μm D263
substrate metalisation	NiCr 100 Ω/sq + 1 μm Al
production dimension	150 x 150 mm ² (0° MSGC ¹) 150 x 200 mm ² (30° MSGC ²)
anode strip width	7 +/- 1 μm
cathode strip width	85 μm
anode pitch	193 μm
cathode plane	75 μm Kapton + 1 μm Cu
gas gap	3 mm

Operating conditions

In combination with the applied counter gas DME/CO₂, a position resolution of 45 μm using digital read out [2] can be achieved. At a gas gain of 1000 a signal to noise ratio of 1:50 is expected for the APC SAC 1. This leads to an expected efficiency of 98% at a discrimination level well above the output noise of the preamplifier.

Table 3.

Operating conditions	
counter gas	DME/CO ₂ 60/40
cathode strip voltage	- 600 V
anode strip voltage	0 V
cath.plane voltage	- 2500 V
expected gas gain	1000

¹ Produced by RMT, Wangs, Switzerland

² Produced by SRON, Utrecht, the Netherlands

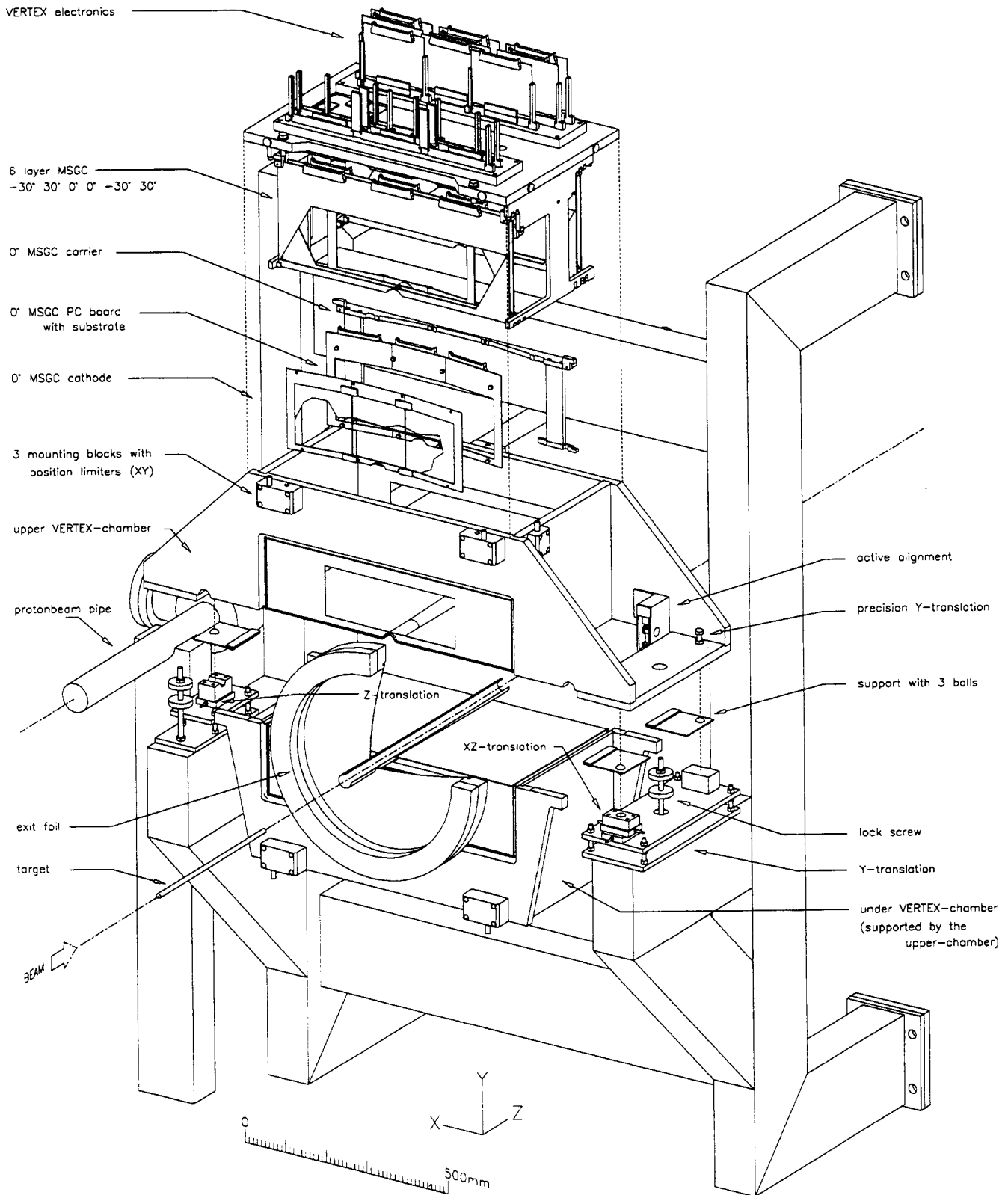

Fig. 2. Assembly of the MSGC system

ASSEMBLY OF THE MSGC TRACKER

Fig. 2. shows the cover of the upper gas housing under which the 6 MSGCs are mounted. The lower gas housing is bolted against the upper one, leaving an aperture for the beam pipe. The full assembly is mounted onto a support frame, attached to the HERMES magnet. On the outside of the gas housing cover the discriminator boards are assembled. They also contain the interface for the control signals of the front end electronics.

For both the gas system and the gas housing, the material choice was not as required for a low ageing rate[5]. However, according to the extrapolated data of a beam test at the Hera electron beam pipe using a gas target with a cross section comparable to the final gas target, the collected charge will be only $16 \mu\text{C}/\text{cm}\cdot\text{year}$. According to the measured ageing curve[3], a loss of 7 % of gain per year may be expected, running at a gain of 1000.

However, another effect may be more important: the drift of the Na^+ ions in the D263 glass. A laboratory test using cosmic rays, that ran for 6 months using the same substrate glass showed a gradual increase of the gas gain of 4 % per month. Therefore, it may occur that at a certain moment the depletion of Na^+ ions near the anode strip has proceeded that far that operation becomes troublesome. To repel this phenomenon, one has to invert the cathode strip voltage during the annual shut down period of Hera.

ELECTRONICS

Front end

As a front end preamplifier the APC 64[4] will be used. This chip has a switched capacitor pipeline of 32 places deep. The sampling occurs in phase with the HERA bunch frequency of 10.4 MHz. Once a trigger occurs, for each channel the signal is stored into a latch capacitor using the method of double correlated sampling. Thereafter, the APC is read out in series at a frequency of 2.5 MHz. Including the initialisation, the total dead time of the front end is expected to be 30 μs . The first half of the tracker will be equipped with the existing APC 64 in the 2 μm SACMOS technology (APC SAC2). Recently, a new version of the APC 64 has been produced in 1 μm SACMOS (APCSAC 1). This new version has important improvements, like speed, gain and noise performance, so it will be used in the second half of the tracker.

Data acquisition

Fig. 3. shows the electronic system that is used to process the data from the APCs. Every APC is read out by an individual discriminator to reduce the dead time of the MSGC system. Since, especially for the APC SAC2, the baseline voltage gradually rises during read out, a sample and hold circuit has been added to keep the baseline to the same level. As soon as a hit is detected, the baseline restore operation is suspended. The baseline restore is activated again when the signal level does no longer meet the discriminator level. The baseline restore will also be automatically activated after two subsequent hits to avoid the occurrence of big clusters caused by the continuously rising baseline.

The first two APC channels are left open to serve as a reference for the baseline restore operation. While reading out the APCs, the full data transfer of each discriminator is stored into a shift register. Thereafter, the addresses of the hits are loaded into a memory stack and subsequently read out via a VME bus. To reduce the trigger dead time, during this operation the APC system is ready to receive another trigger. In this case the new event remains stored into the APC pipeline memory until the data transfer of the previous event from the shift registers has been completed.

MSGC readout

(4 x X, U & V plane)

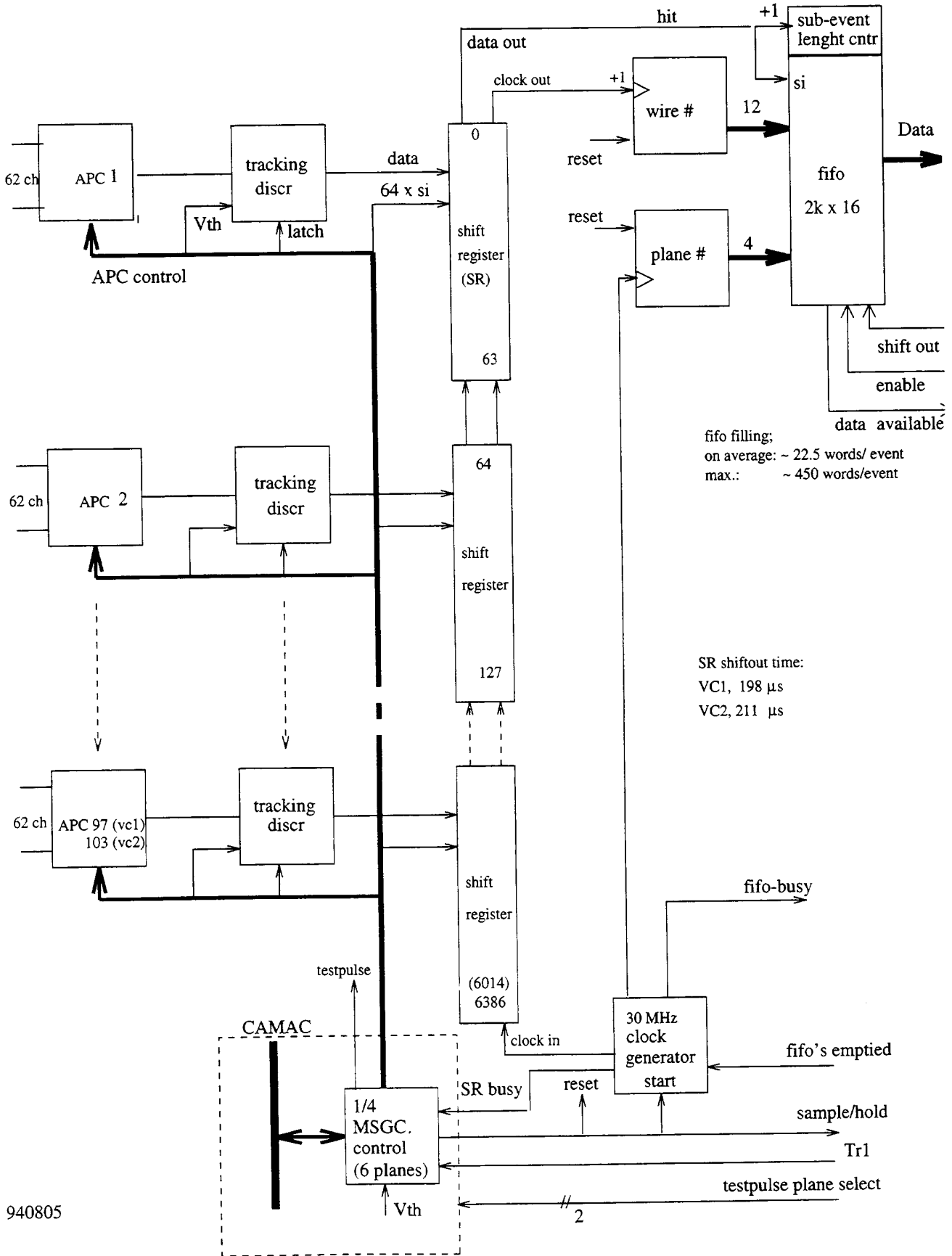

Fig. 3. Survey of the read out electronics

References

- [1] The HERMES Collaboration: Technical Design Report, July 1993.
- [2] F.D. v.d. Berg et al., NIM A 349 (1994) 438.
- [3] F.Udo, talk given on the RD28 meeting , CERN October 16, 1992.
- [4] R. Horisberger and D.Pitzl, NIM A 326 (1993) 92.
- [5] R. Bouclier et al., preprint CERN-PPE/94-63, 92.03.1994.

