

MACHINE STEP 6

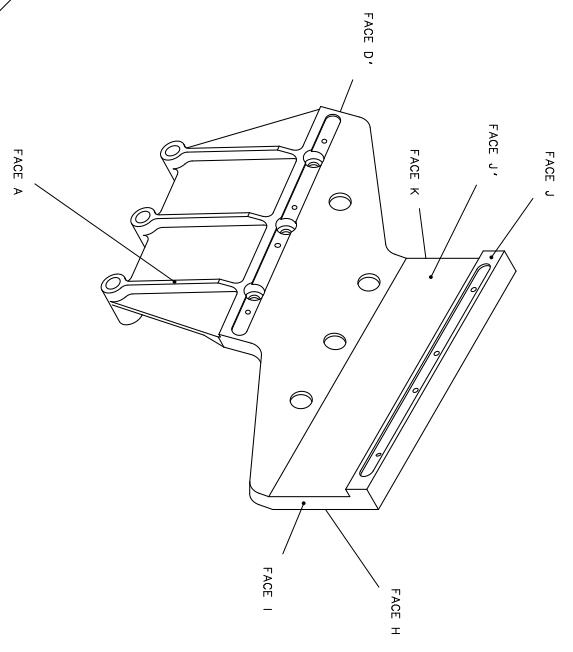
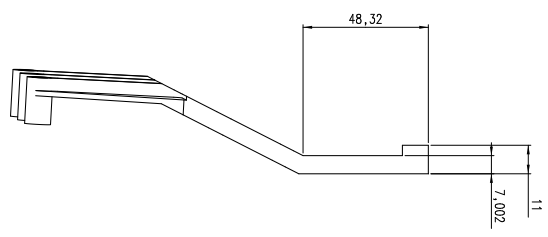
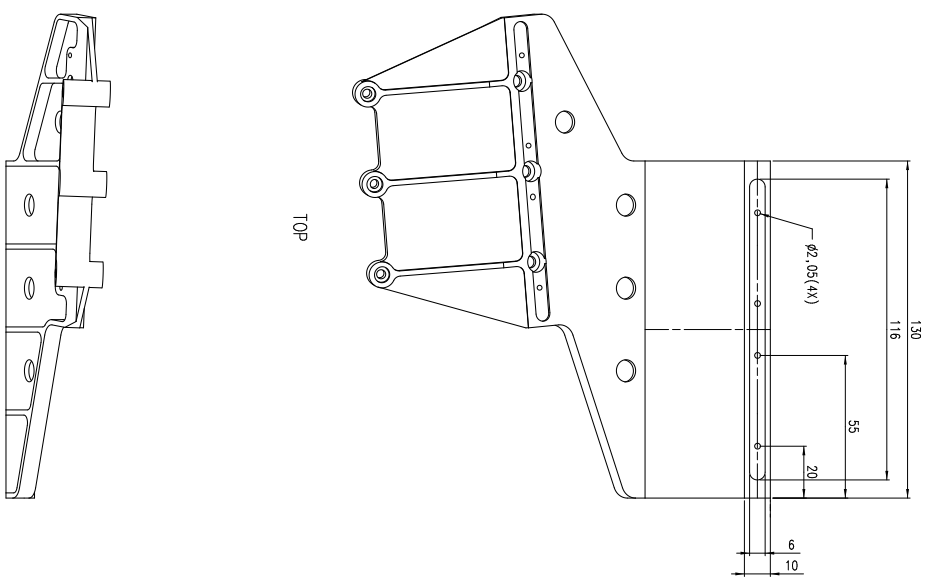

- TURN PART AROUND
- CLAMP BETWEEN FACE I AND K
- SUPPORT ON FACE G

FOR INFORMATION ONLY

Q1	X	XX													
FORM NO.	HER		TITLE	MATERIAL	SIZE/NOTE	I.D. NO./REV									
Project: TICS - Tracker Thermal Control System															
Title: Flange exit clamp base (mill order)															
Scale:	1:1		Drawn:	L.S. D'Agostin	Checked:										
Date:	25-9-2003		Part Name:	FLANGE EXIT CLAMP BASE	Part No.:	2785-17-01	Rev.:	1	ISO 1502						
<table border="0"> <tr> <td>Author:</td> <td>SMO/BO3</td> <td>Sheet No.:</td> <td>6</td> <td>Number of sheets:</td> <td>8</td> </tr> </table>										Author:	SMO/BO3	Sheet No.:	6	Number of sheets:	8
Author:	SMO/BO3	Sheet No.:	6	Number of sheets:	8										



http://www.nikef.it/italy/eng/technical/productions/Tracker/Tracker/P1/28/Tracker/cont03/cont03_6.pjs